

Actividades para mejorar motricidad fina

Sigue los huevos para unir la gallina y el pollito

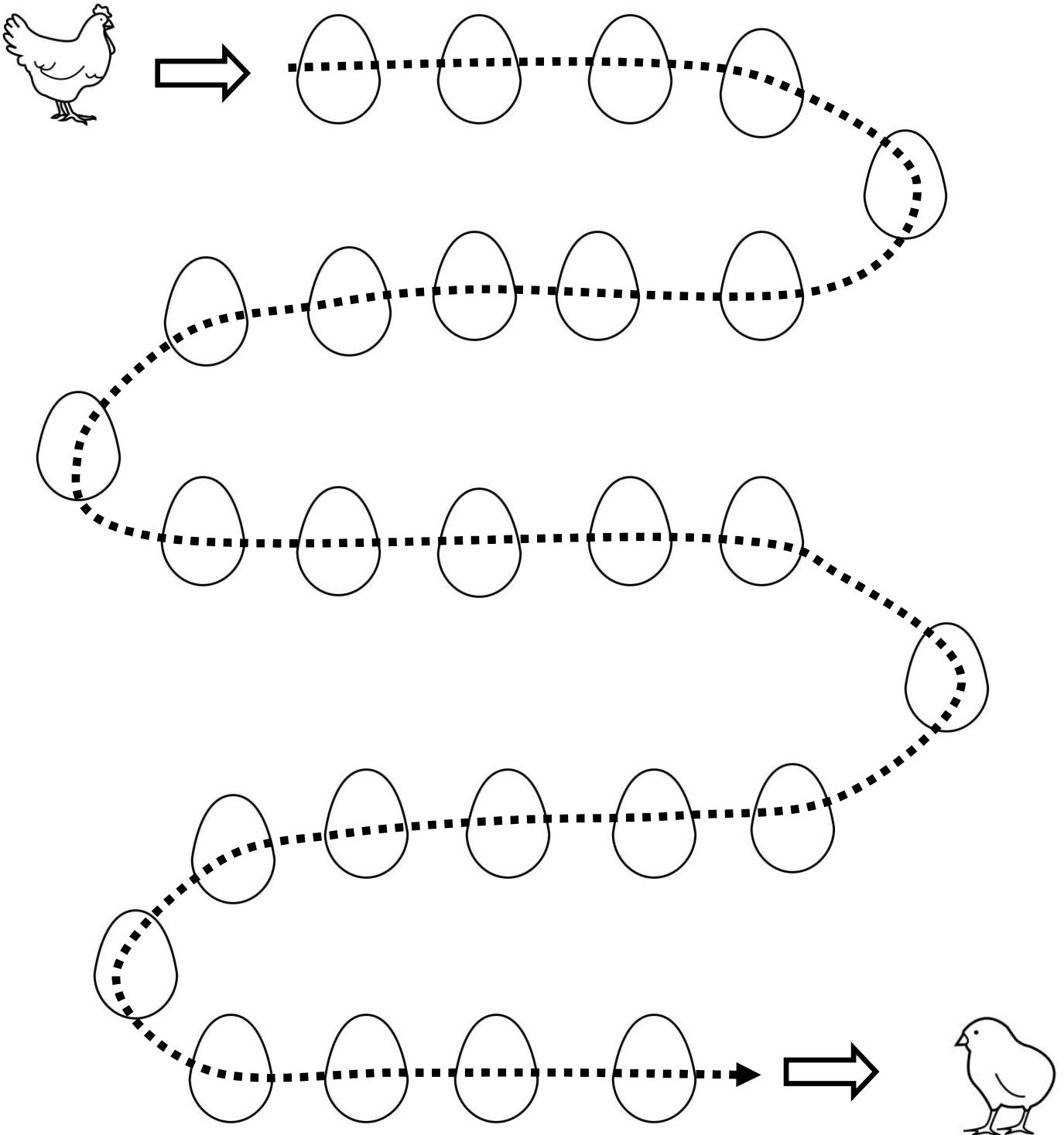

Actividades para mejorar motricidad fina

Sigue los huevos para unir la gallina y el pollito

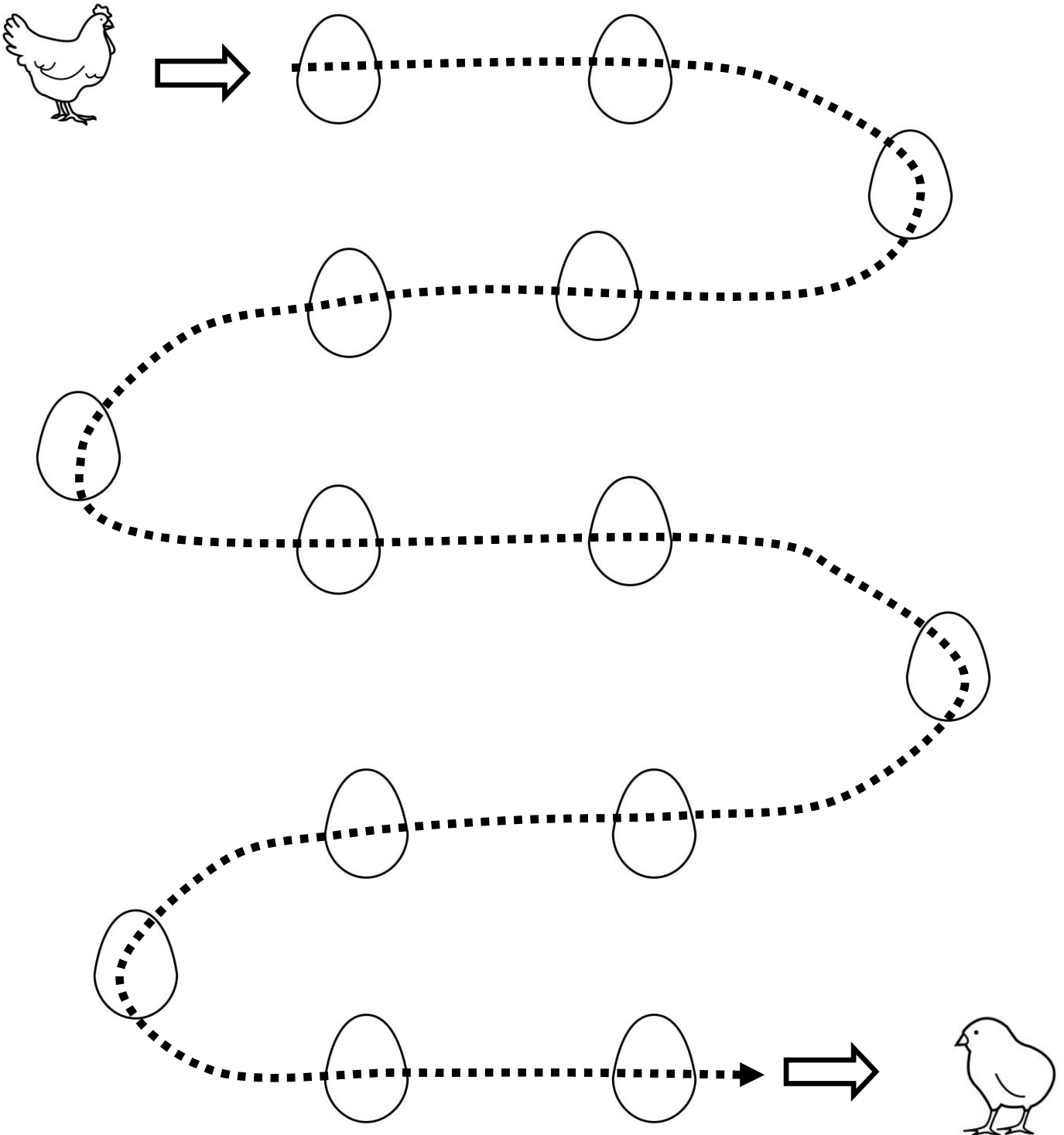

Actividades para mejorar motricidad fina

Sigue los huevos para unir la gallina y el pollito

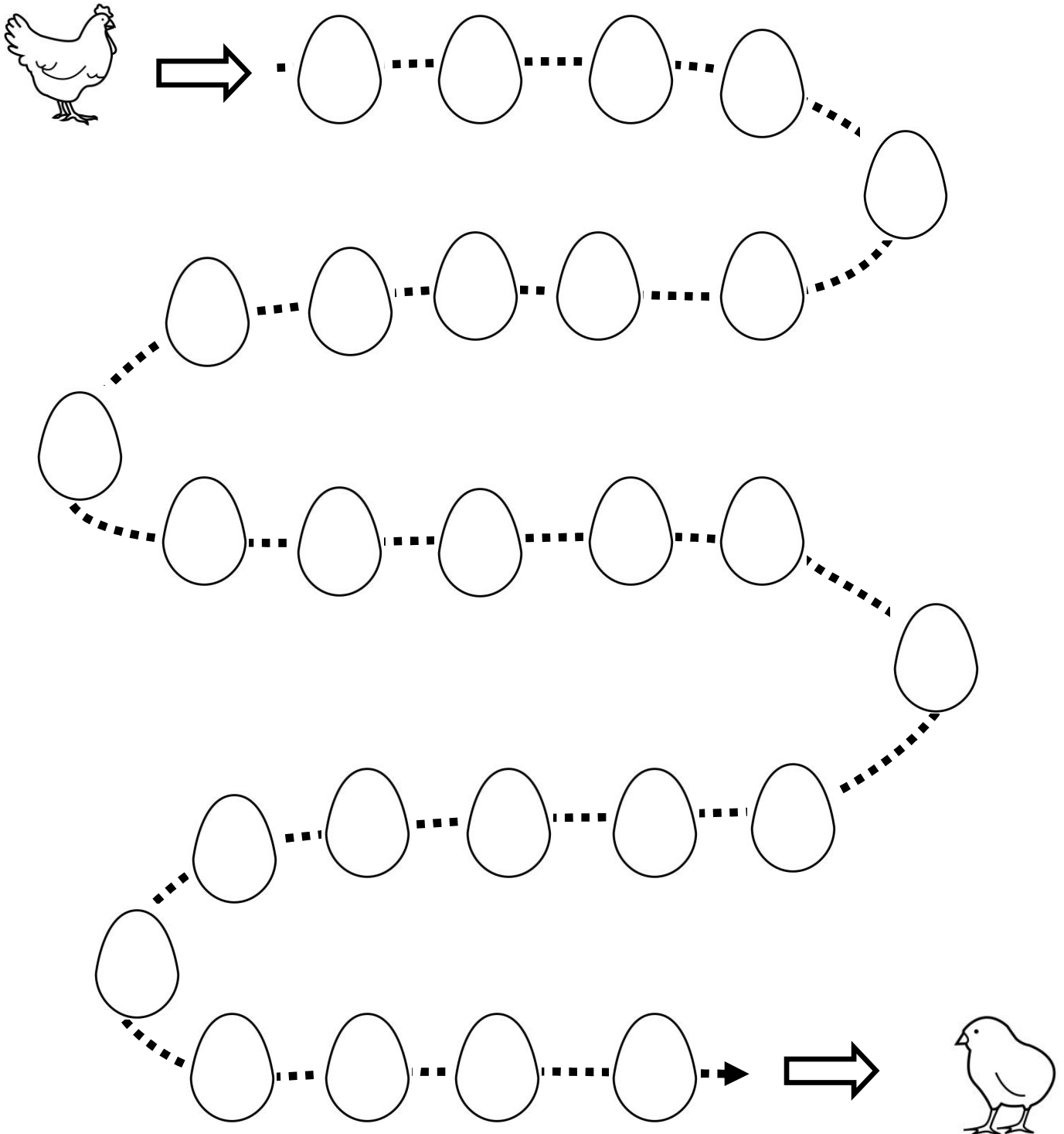

Actividades para mejorar motricidad fina

Sigue los huevos para unir la gallina y el pollito

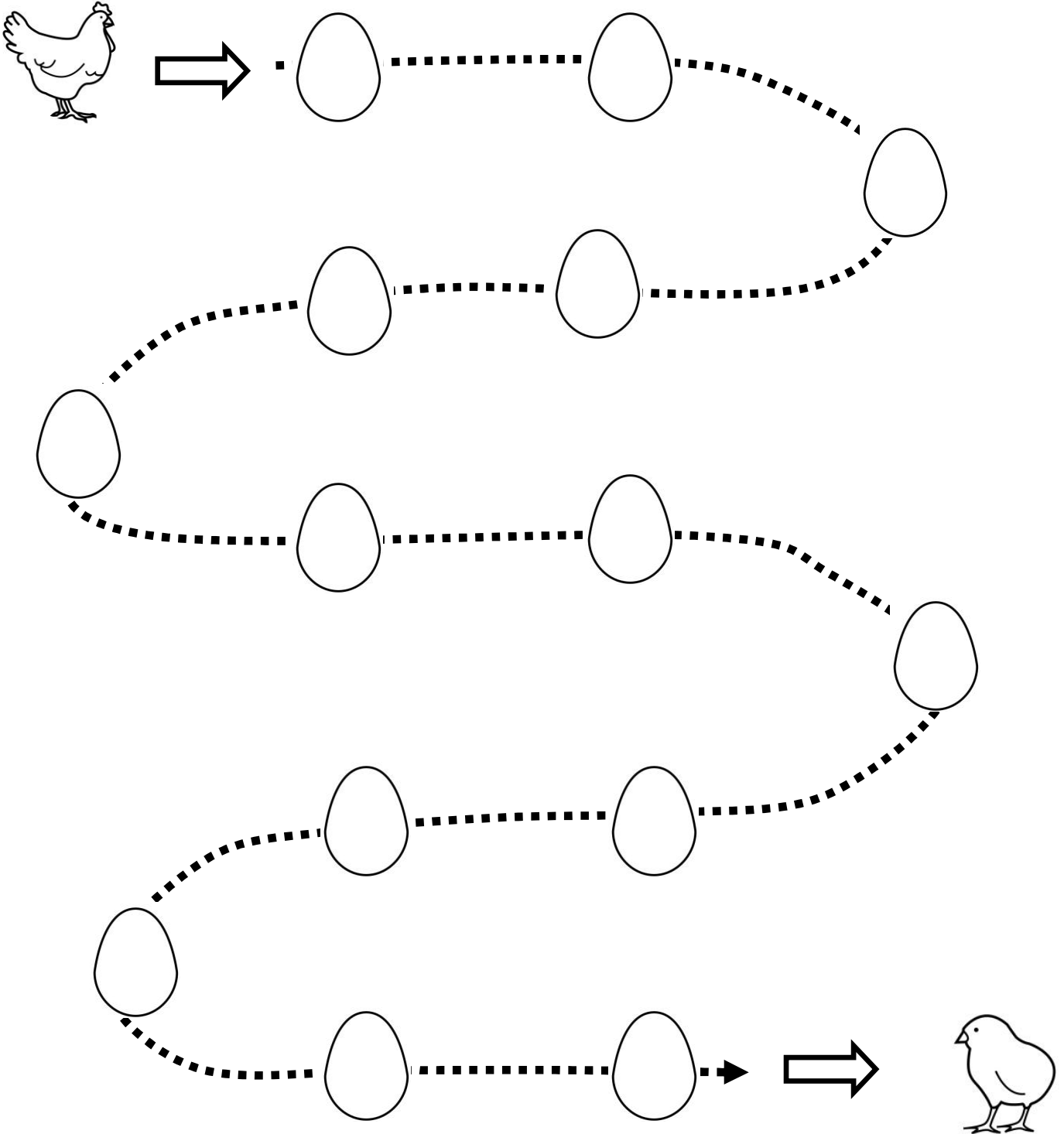

Actividades para mejorar motricidad fina

Sigue los huevos para unir la gallina y el pollito

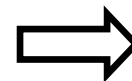
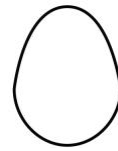
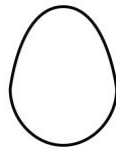
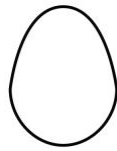
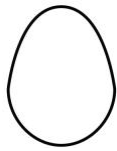
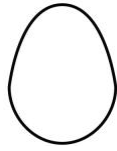
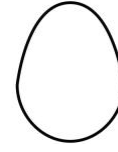
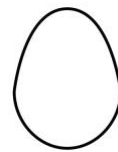
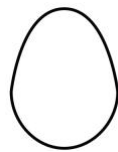
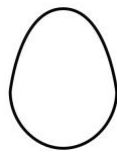
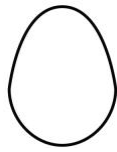
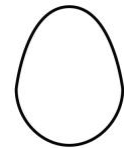
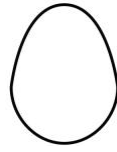
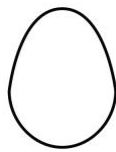
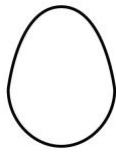
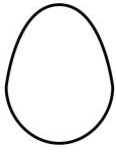
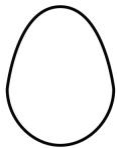
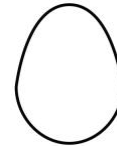
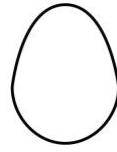
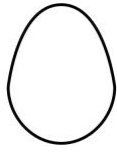
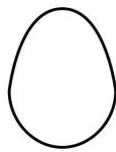
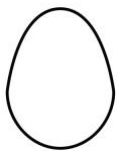
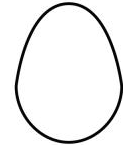
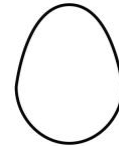
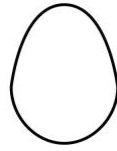
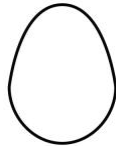
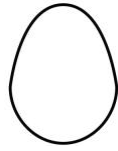
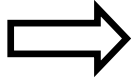
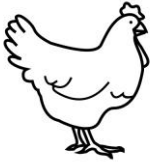

Actividades para mejorar motricidad fina

Sigue los huevos para unir la gallina y el pollito

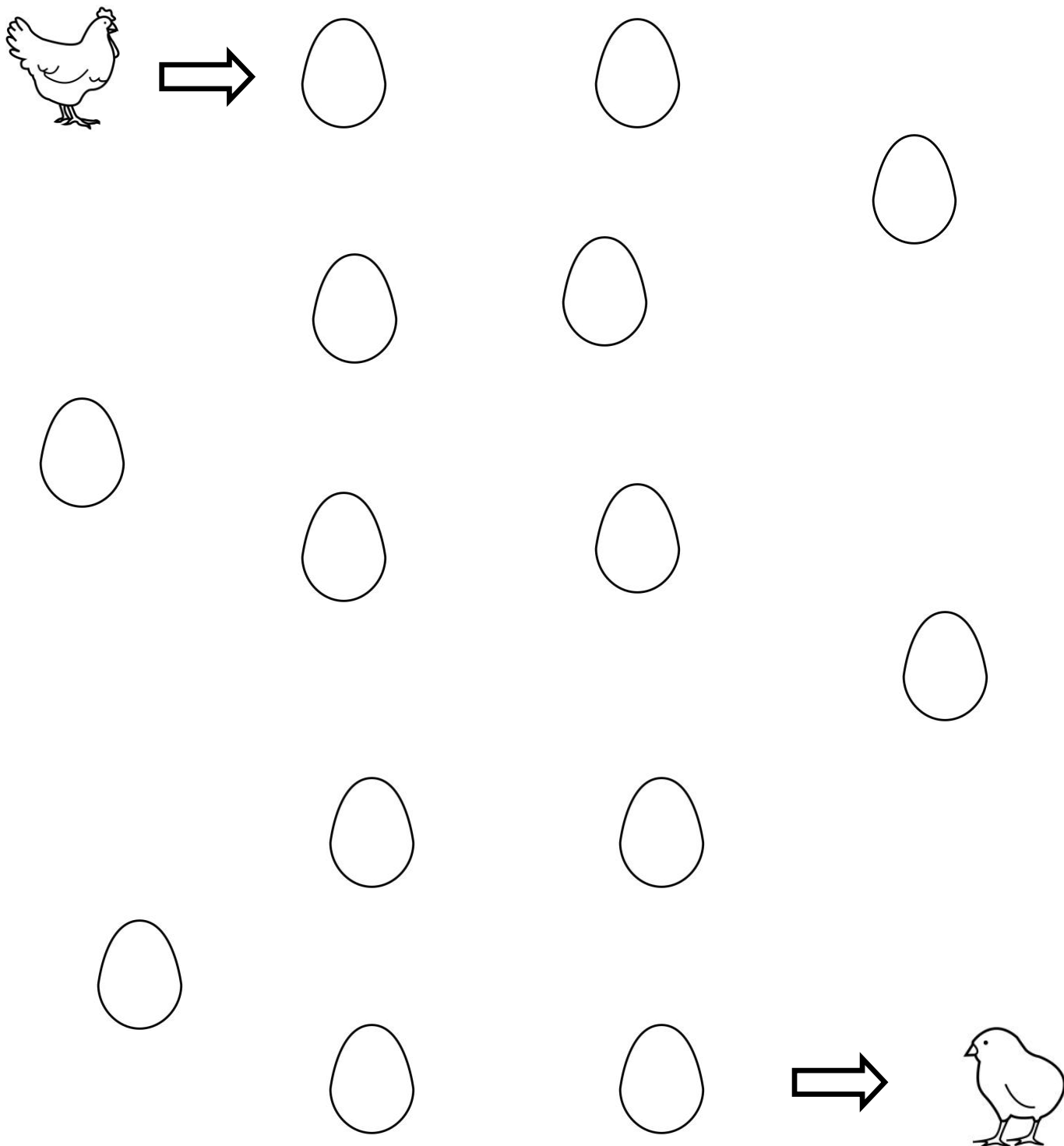

Grafomotricidad formas y cenefas

□										
□										
□										
□										

□	□									
□	□									
□	□									
□	□									

□										
□										
□										

Grafomotricidad formas y cenefas

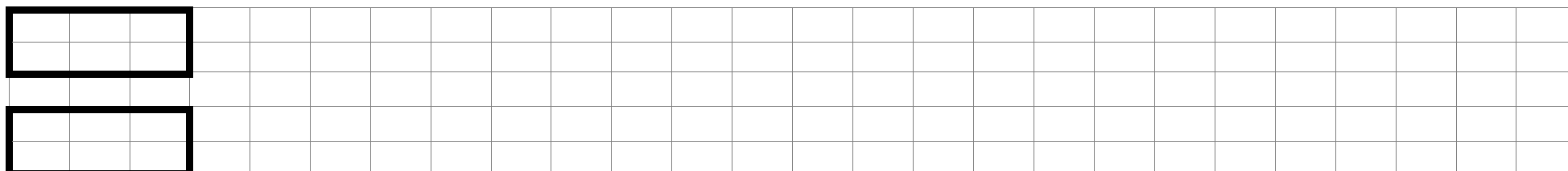
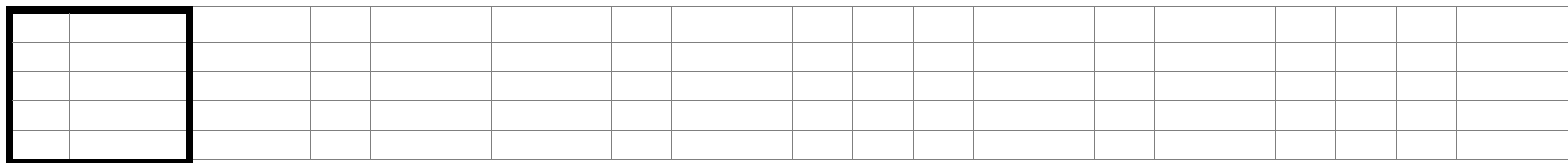
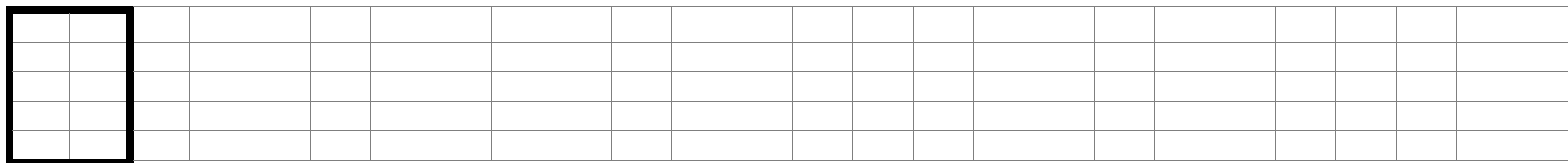
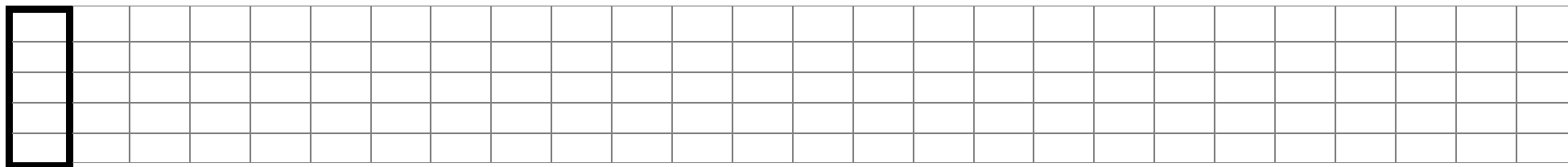

Grafomotricidad formas y cenefas

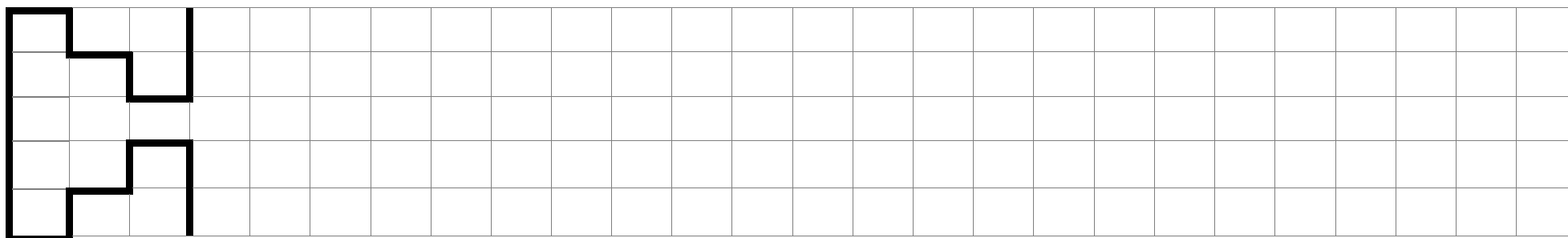
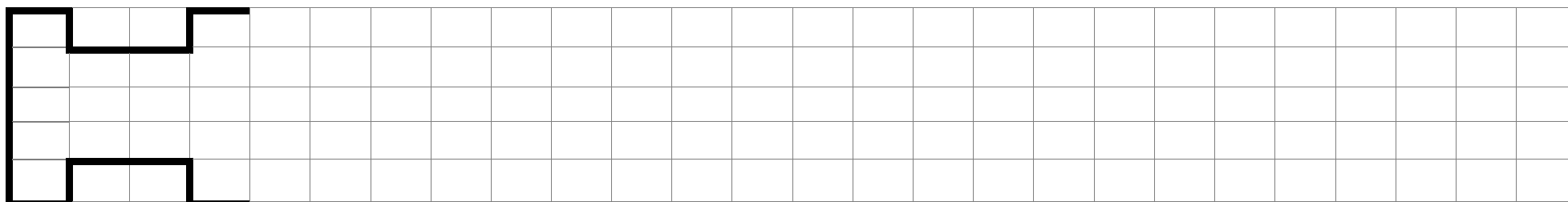
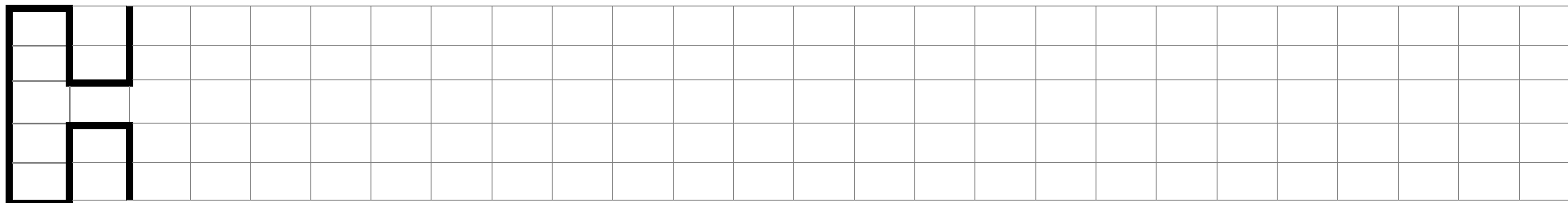

Actividades para mejorar la psicomotricidad

Sigue los huevos para unir la gallina y el pollito

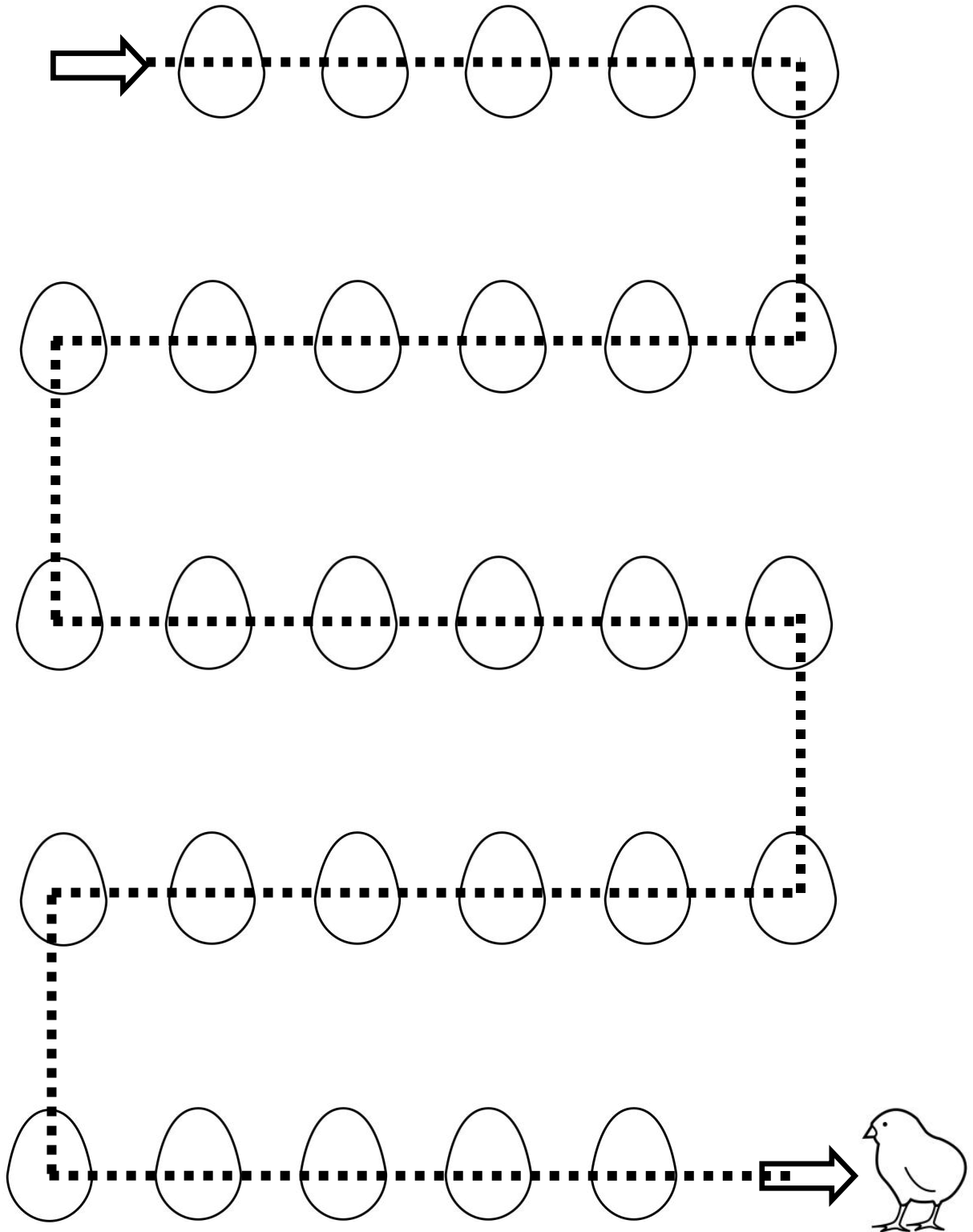
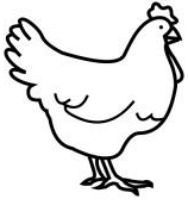

Actividades para mejorar la psicomotricidad

Sigue los huevos para unir la gallina y el pollito

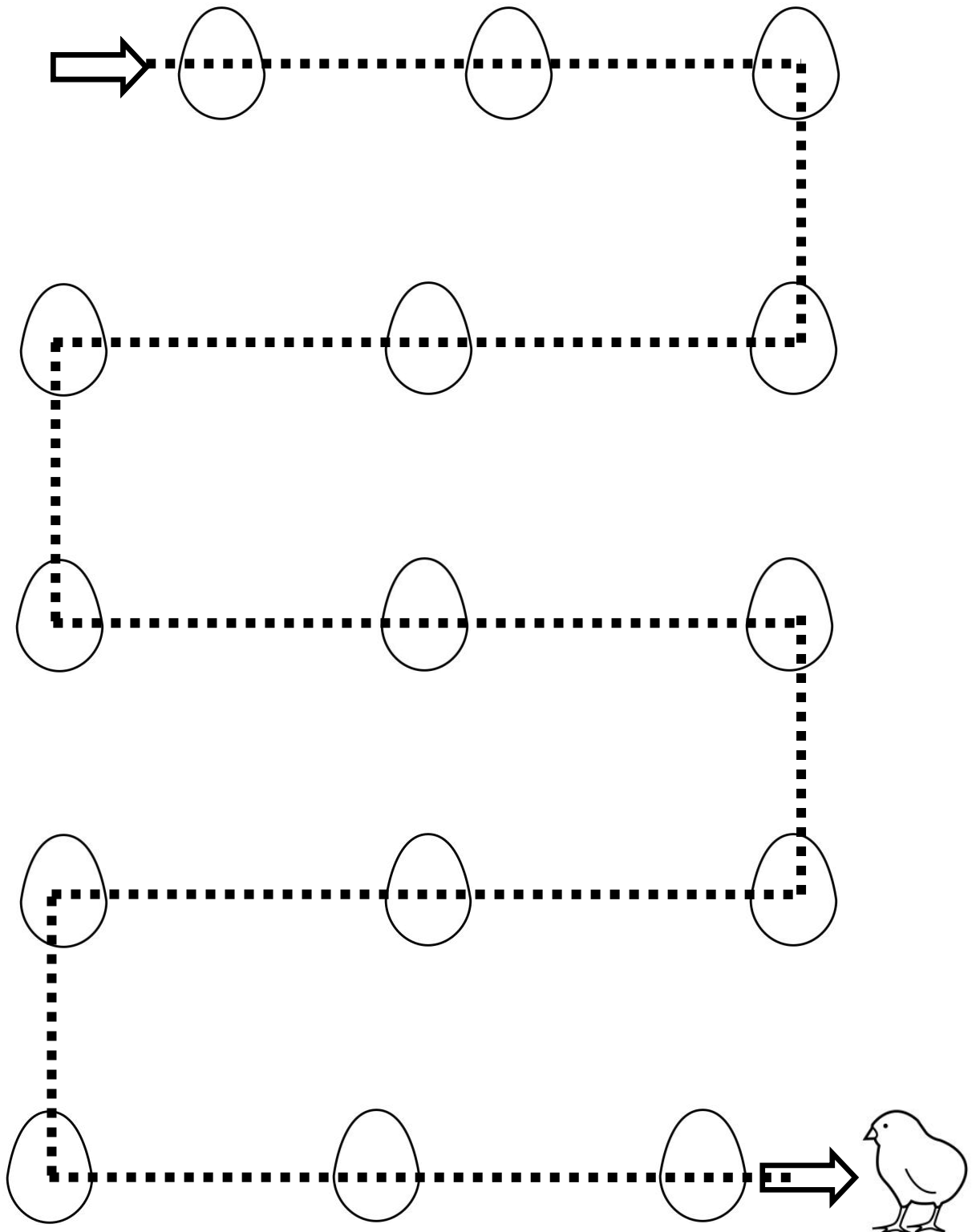
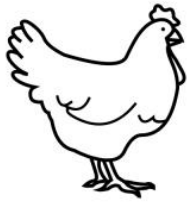

Actividades para mejorar la psicomotricidad

Sigue los huevos para unir la gallina y el pollito

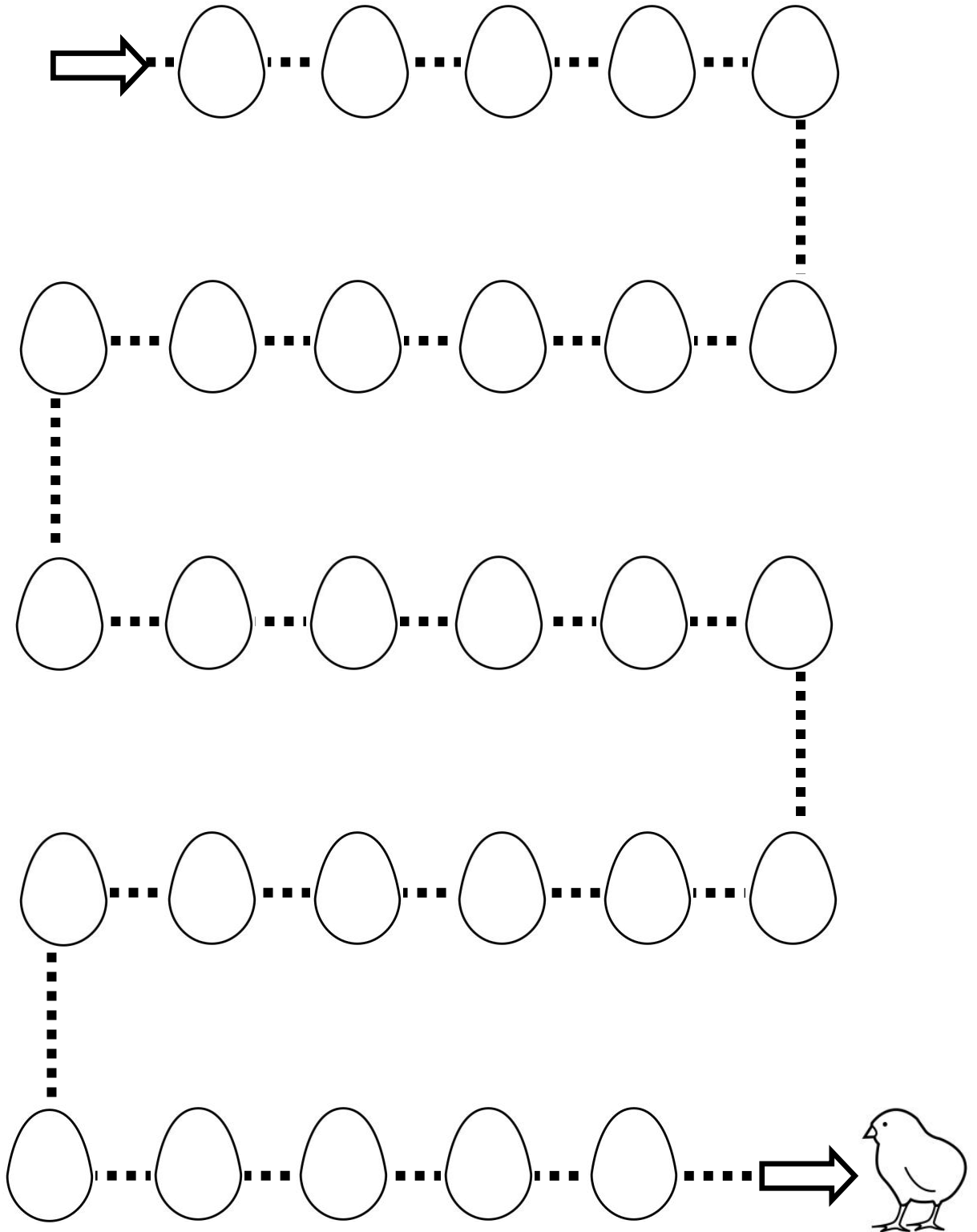
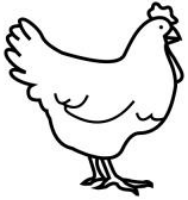

Actividades para mejorar la psicomotricidad

Sigue los huevos para unir la gallina y el pollito

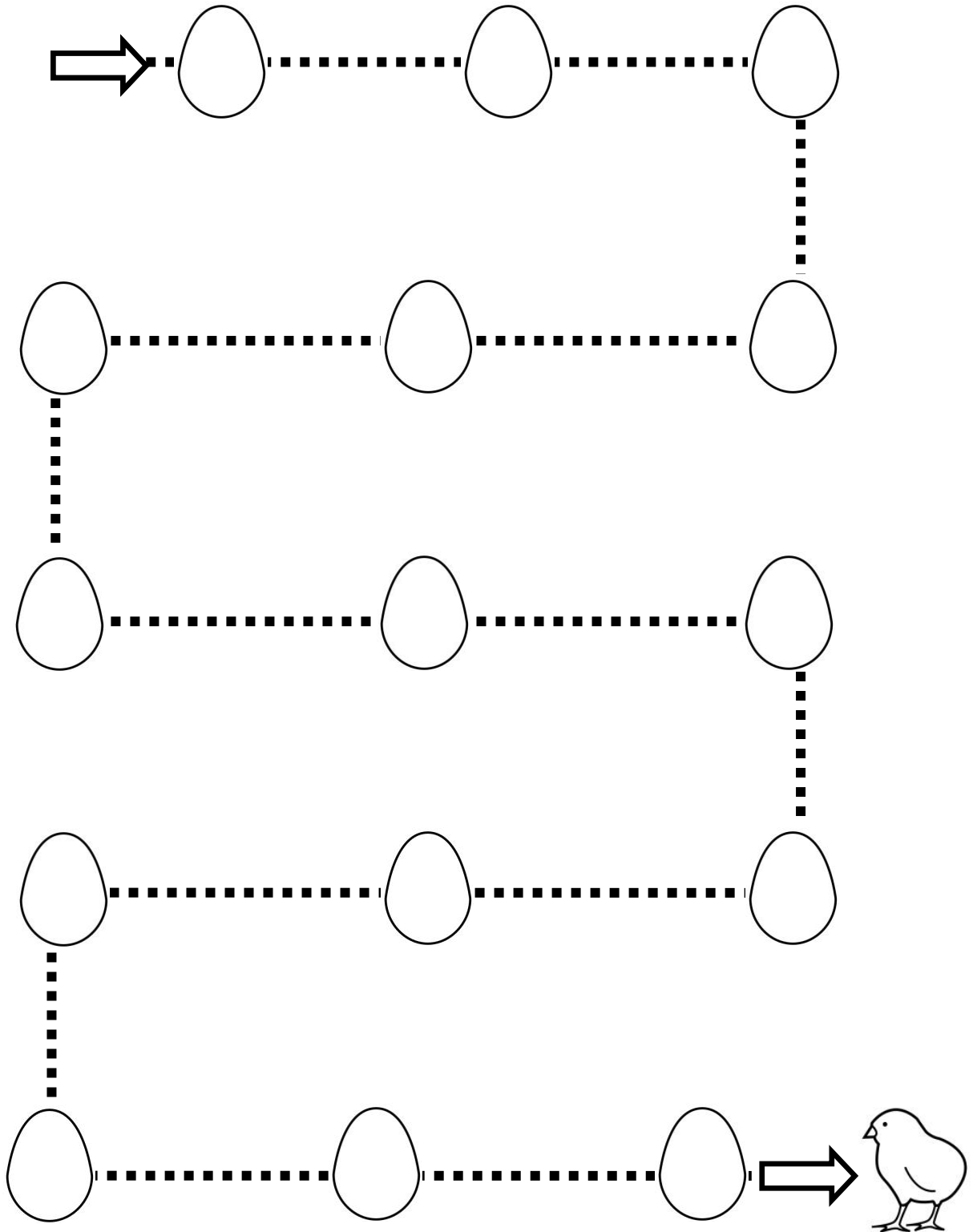
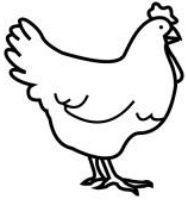

Actividades para mejorar la psicomotricidad

Sigue los huevos para unir la gallina y el pollito

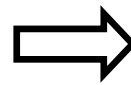
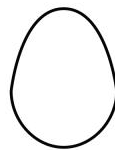
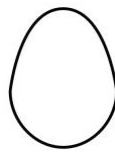
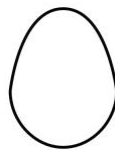
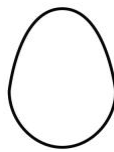
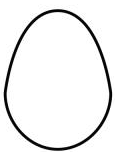
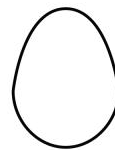
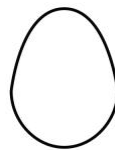
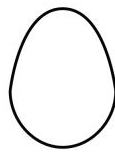
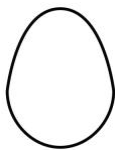
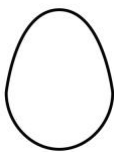
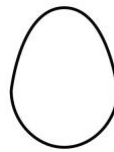
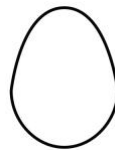
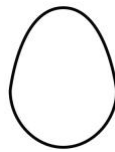
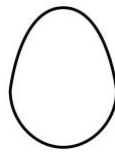
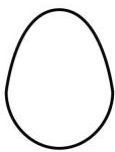
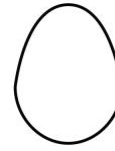
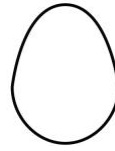
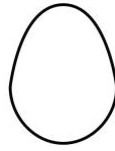
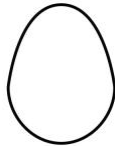
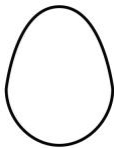
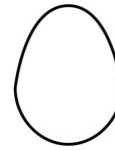
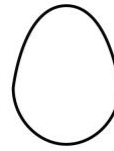
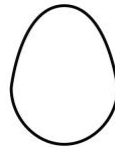
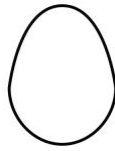
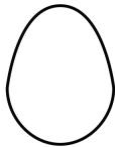
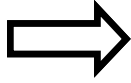
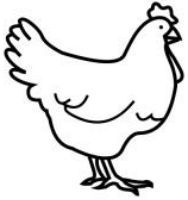

Actividades para mejorar la psicomotricidad

Sigue los huevos para unir la gallina y el pollito

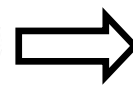
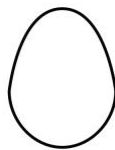
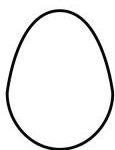
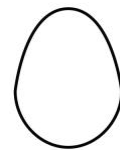
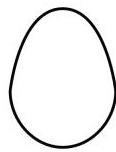
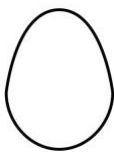
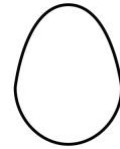
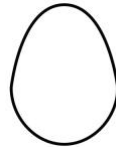
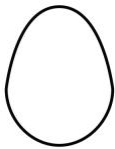
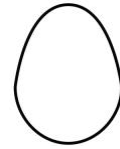
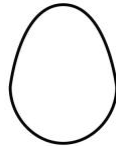
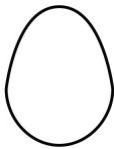
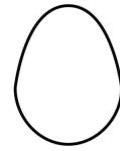
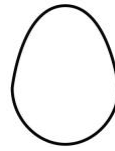
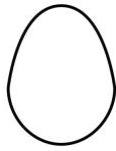
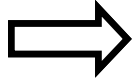
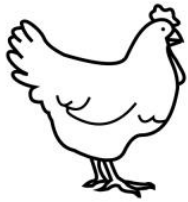

Actividades para mejorar la psicomotricidad

Sigue los corazones para unir a la mama y a su bebe

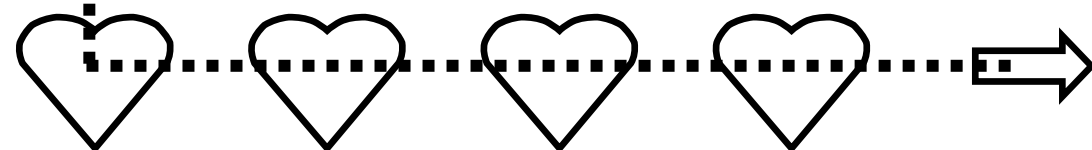
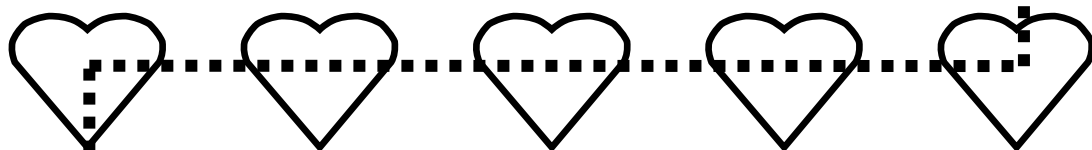
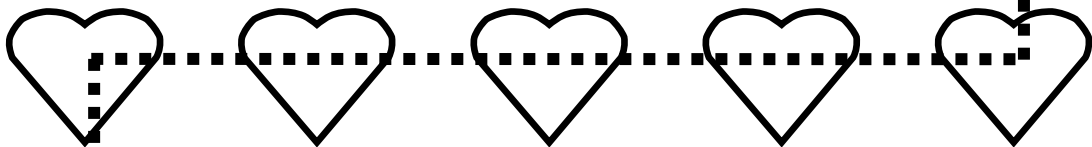
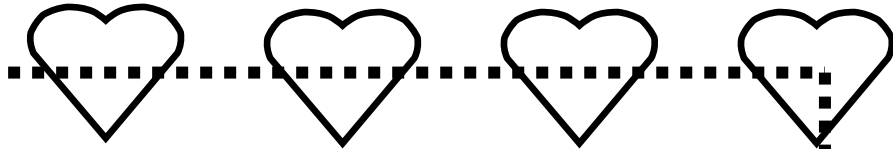
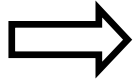

Actividades para mejorar la psicomotricidad

Sigue los corazones para unir a la mama y a su bebe

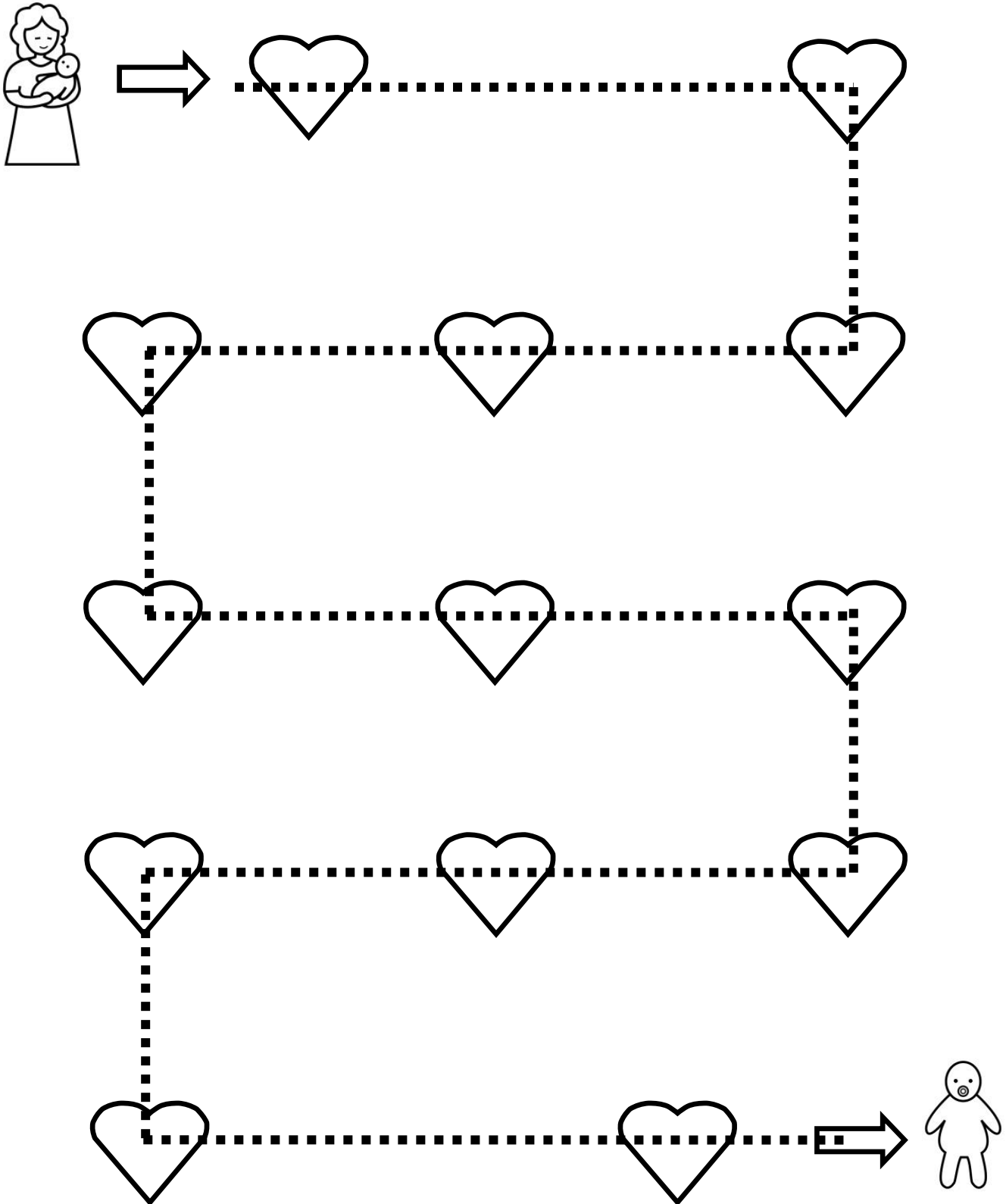

Actividades para mejorar la psicomotricidad

Sigue los corazones para unir a la mama y a su bebe

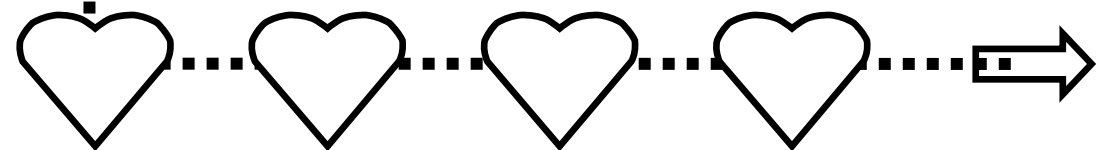
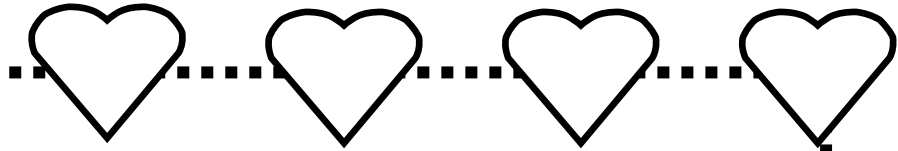

Actividades para mejorar la psicomotricidad

Sigue los corazones para unir a la mama y a su bebe

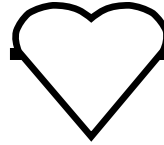
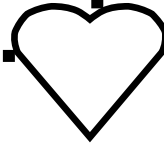
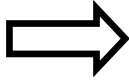

Actividades para mejorar la psicomotricidad

Sigue los corazones para unir a la mama y a su bebe

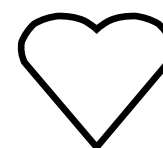
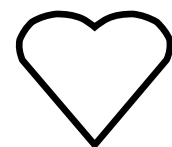
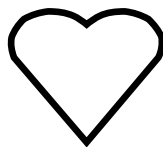
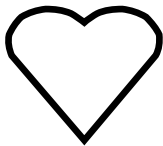

Actividades para mejorar la psicomotricidad

Sigue los corazones para unir a la mama y a su bebe

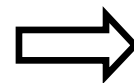
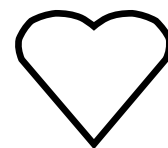
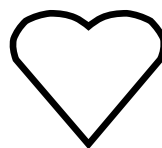
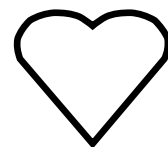
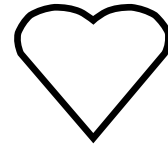

Actividades para mejorar la psicomotricidad

Sigue las caras para unir al niño y a la niña

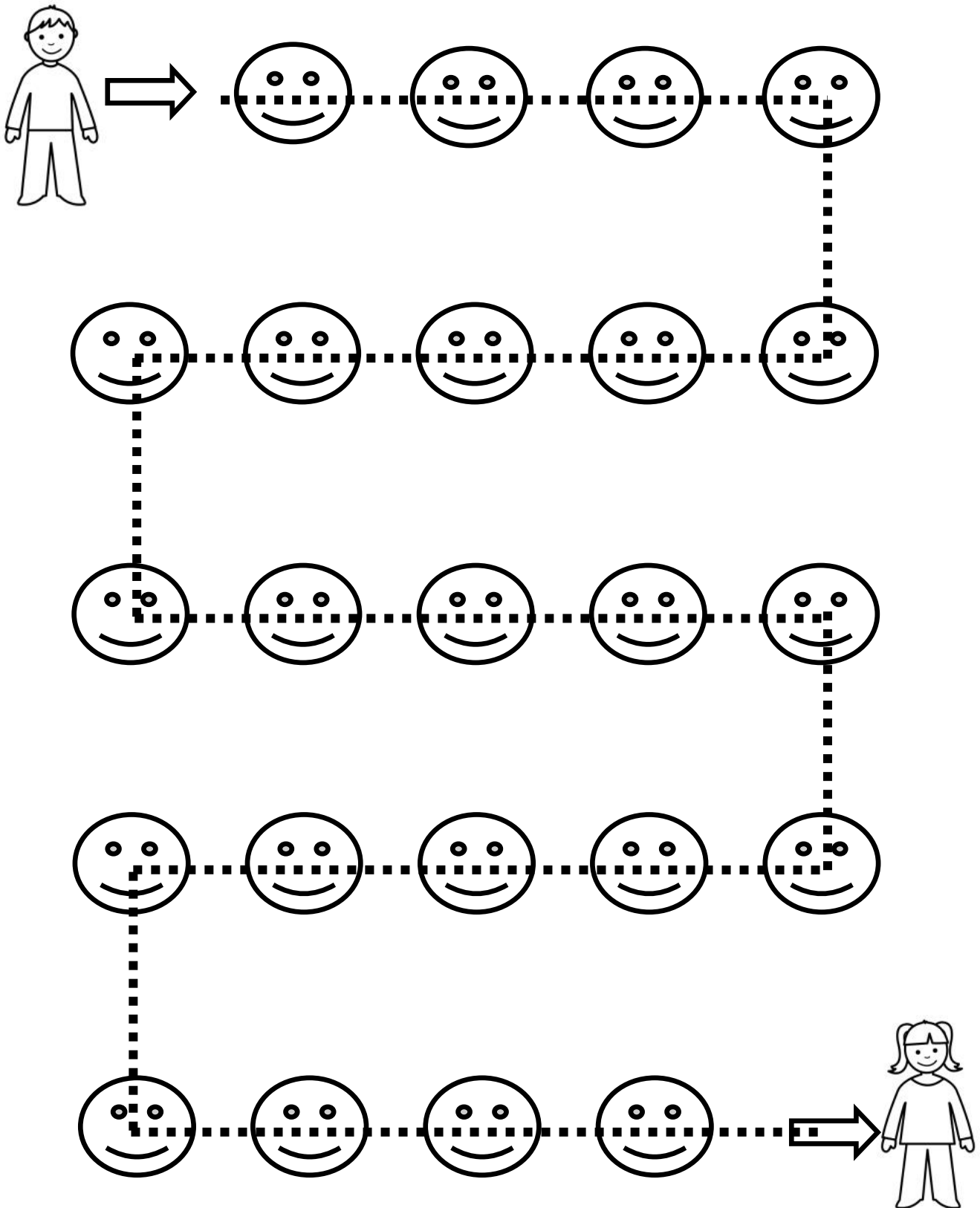

Actividades para mejorar la psicomotricidad

Sigue las caras para unir al niño y a la niña

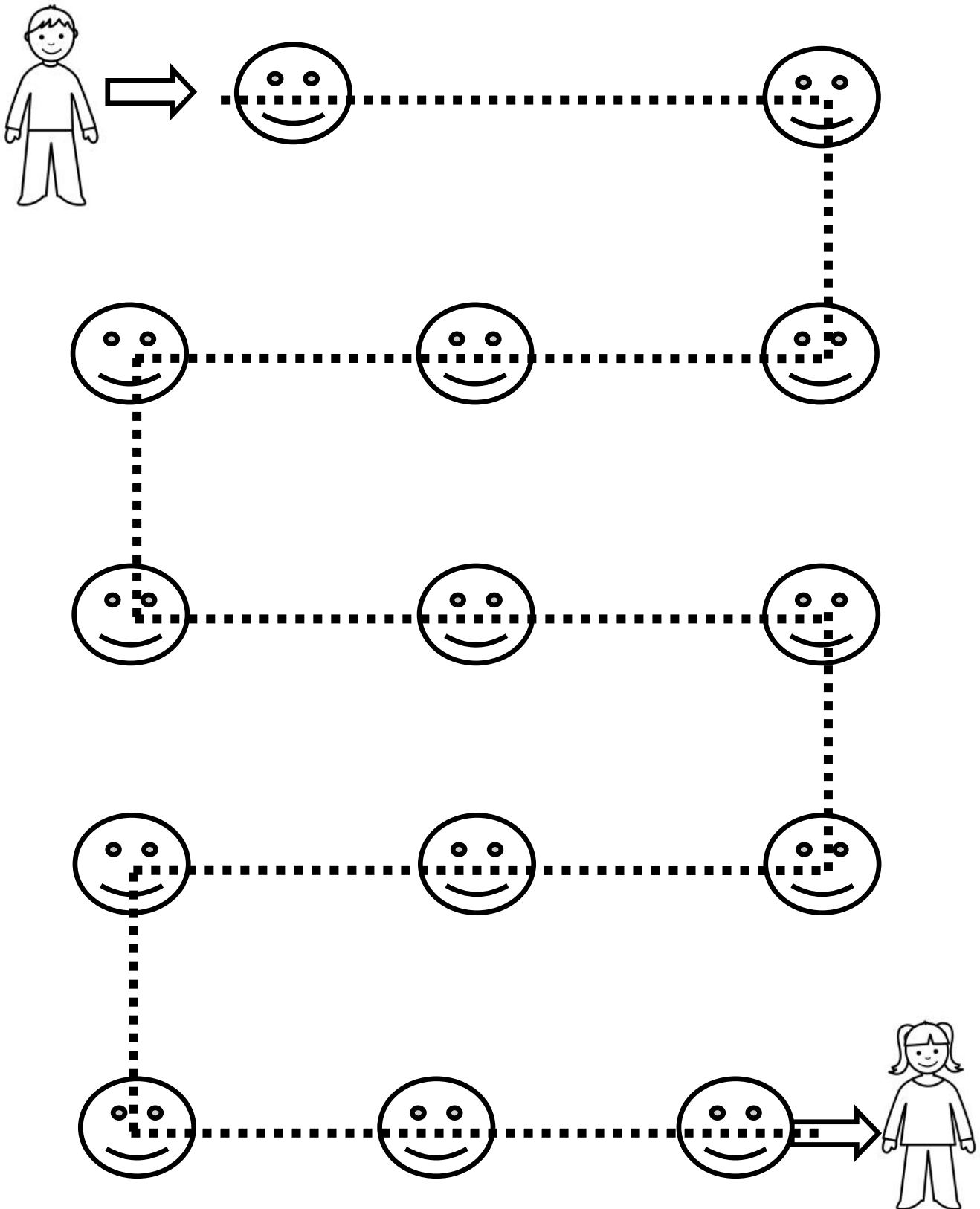

Actividades para mejorar la psicomotricidad

Sigue las caras para unir al niño y a la niña

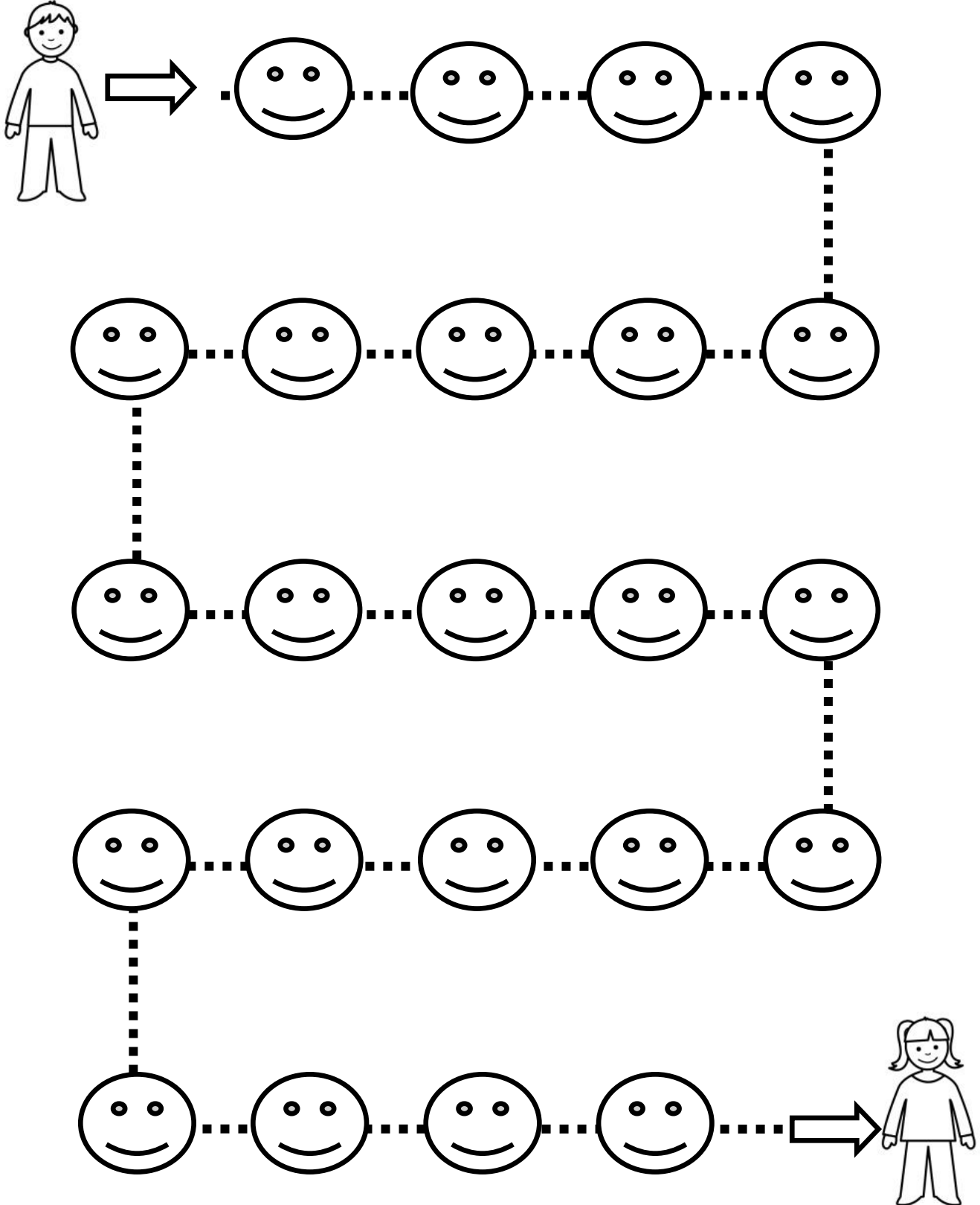

Actividades para mejorar la psicomotricidad

Sigue las caras para unir al niño y a la niña

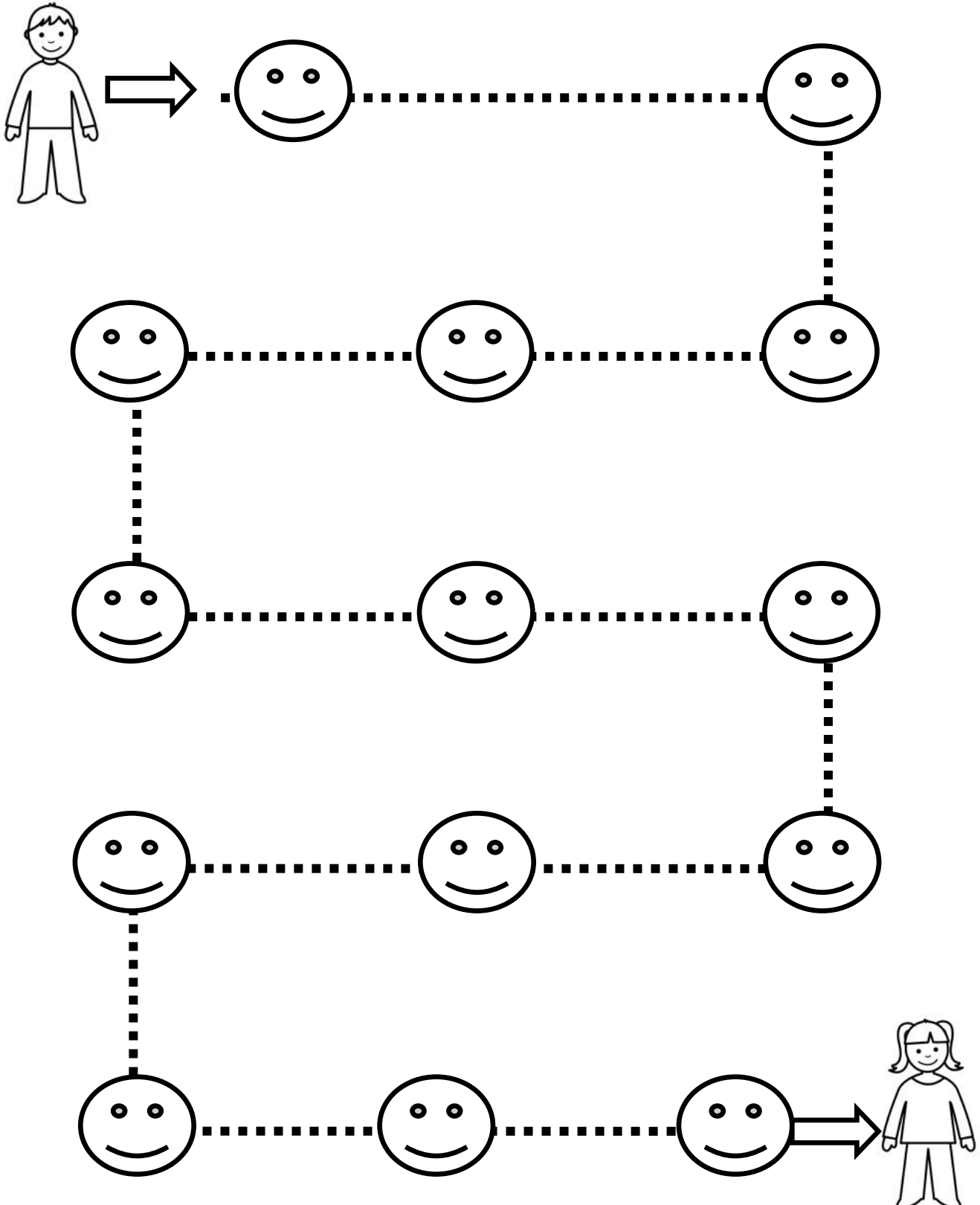

Actividades para mejorar la psicomotricidad

Sigue las caras para unir al niño y a la niña

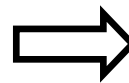
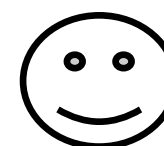
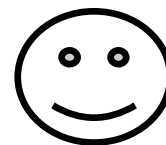
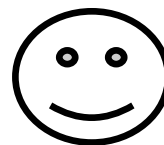
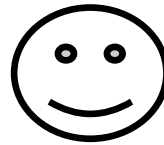
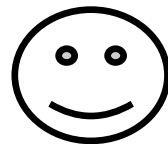
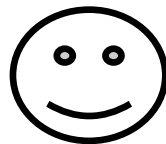
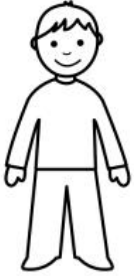

Actividades para mejorar la psicomotricidad

Sigue las caras para unir al niño y a la niña

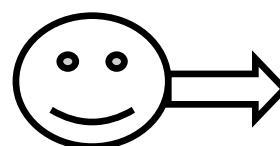
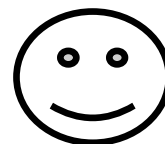
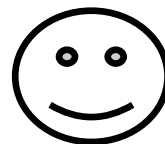
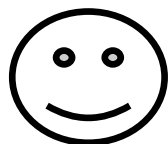
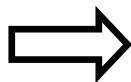
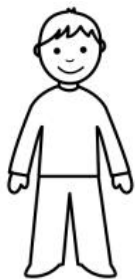

Actividades para mejorar la psicomotricidad

Sigue los círculos para unir al niño con su balón

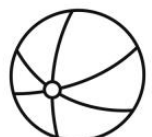
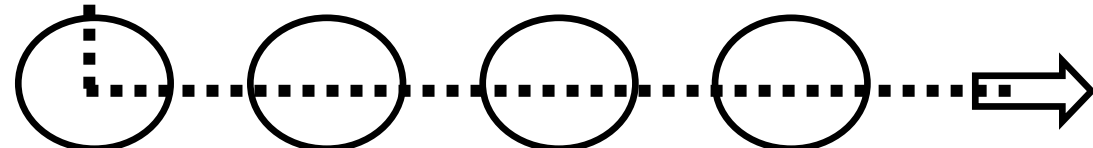
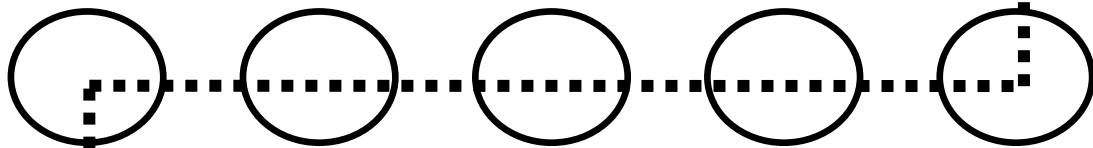
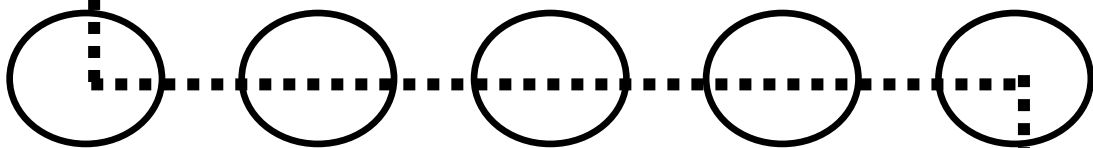
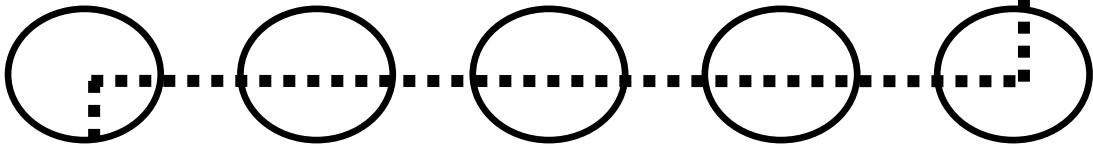
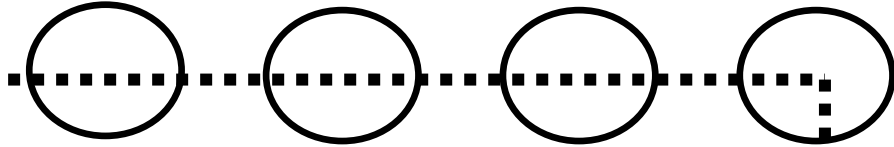
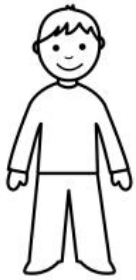

Actividades para mejorar la psicomotricidad

Sigue los círculos para unir al niño con su balón

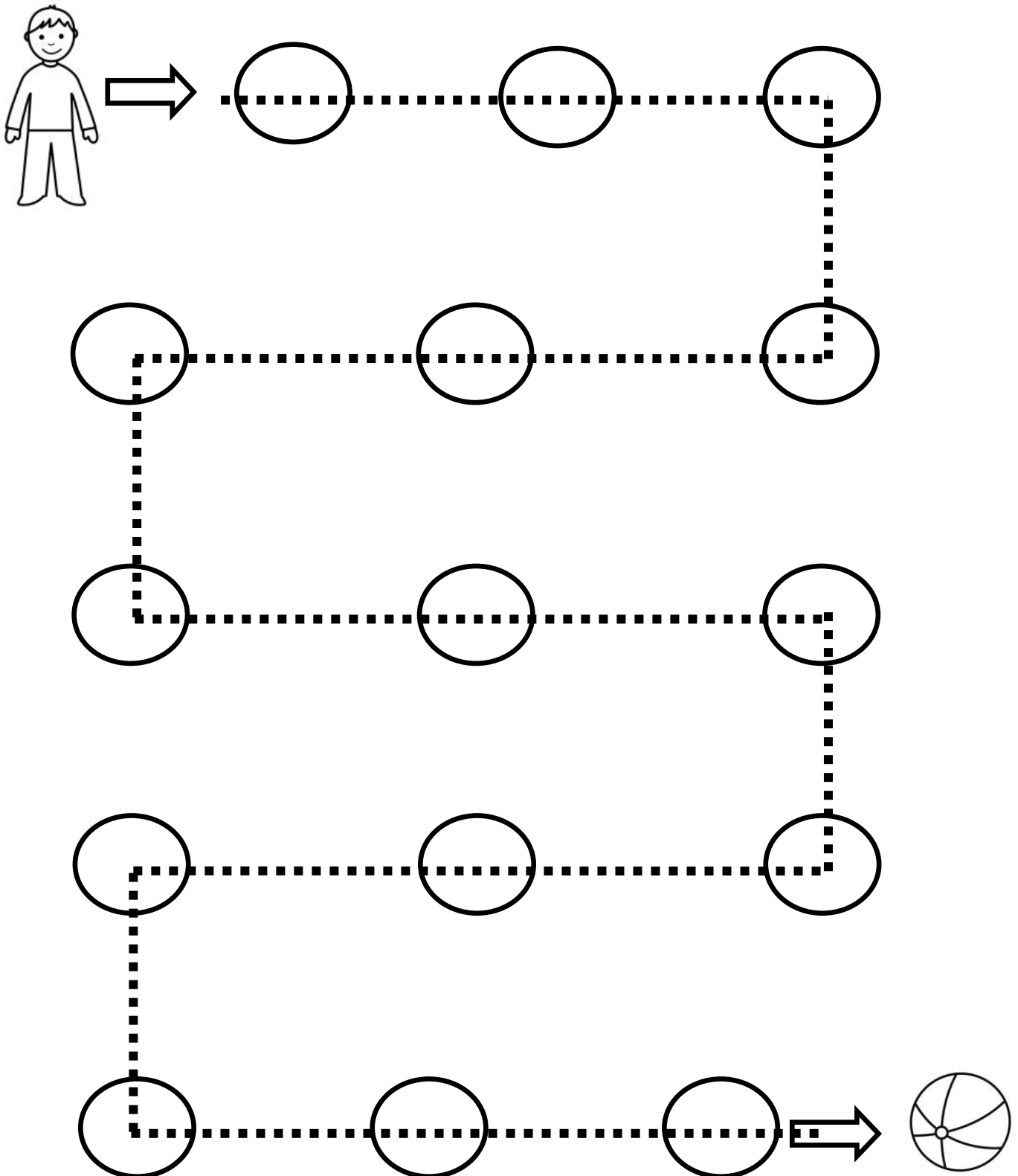

Actividades para mejorar la psicomotricidad

Sigue los círculos para unir al niño con su balón

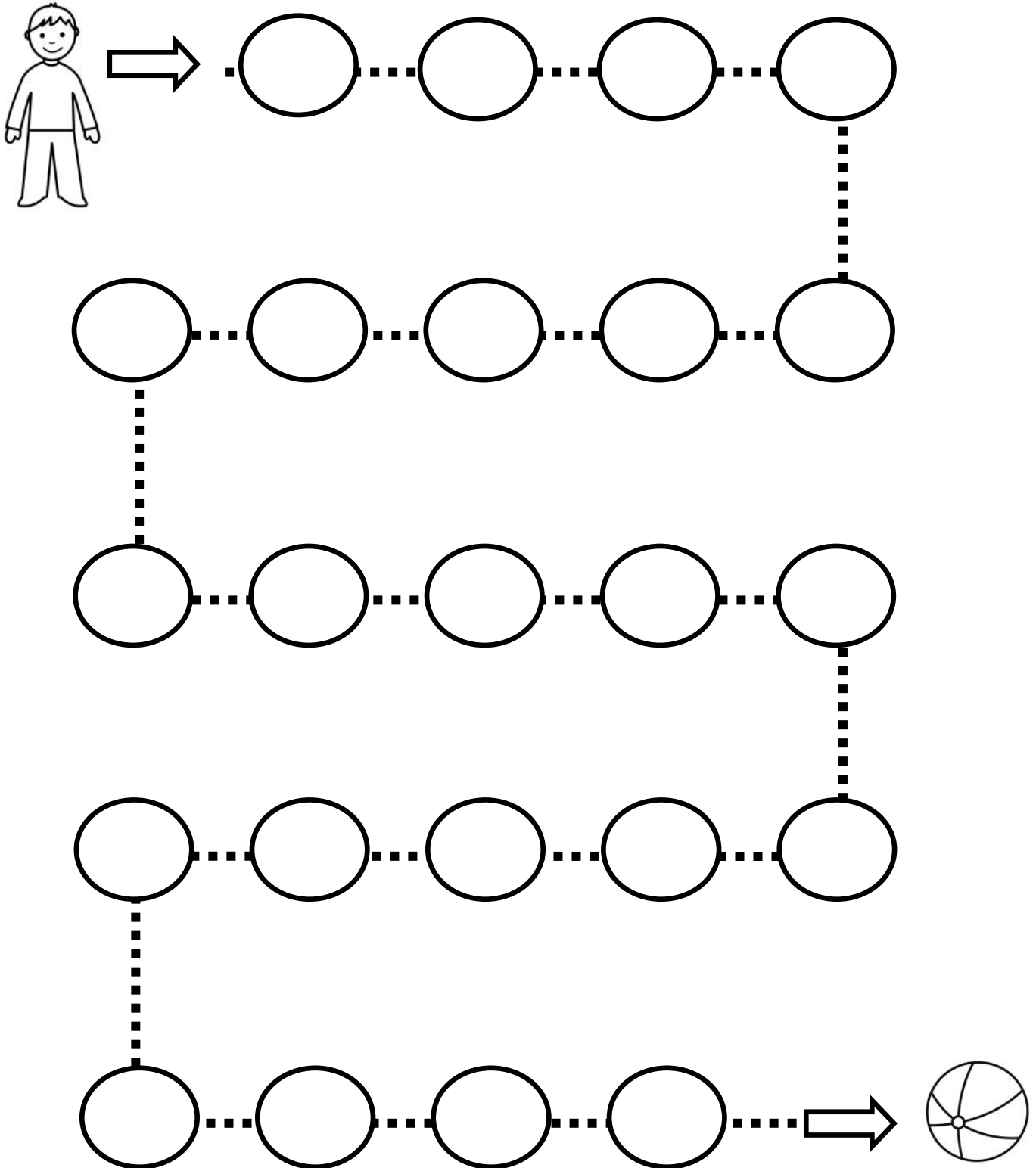

Actividades para mejorar la psicomotricidad

Sigue los círculos para unir al niño con su balón

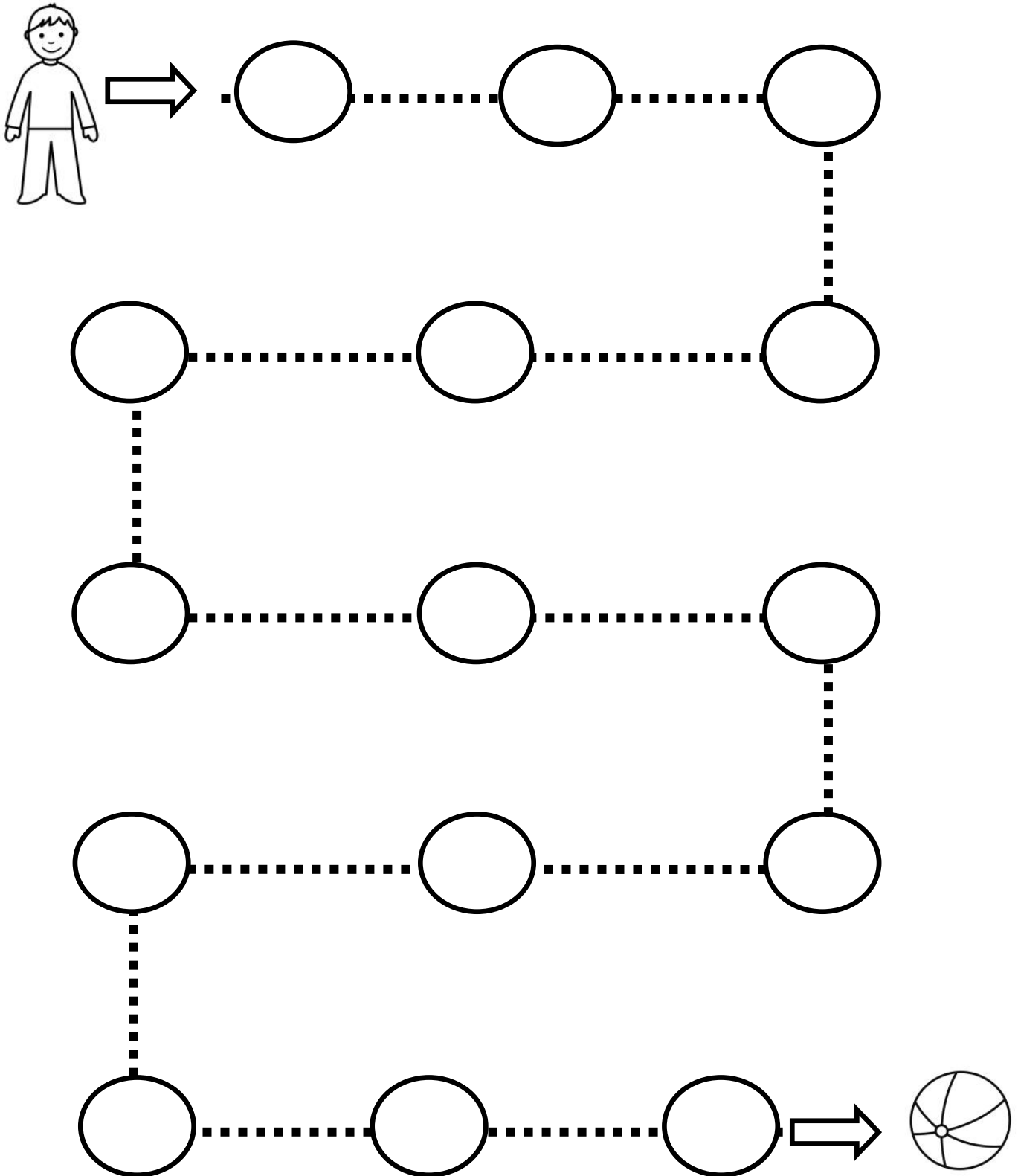

Actividades para mejorar la psicomotricidad

Sigue los círculos para unir al niño con su balón

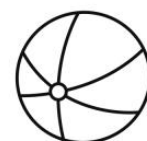
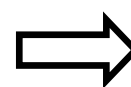
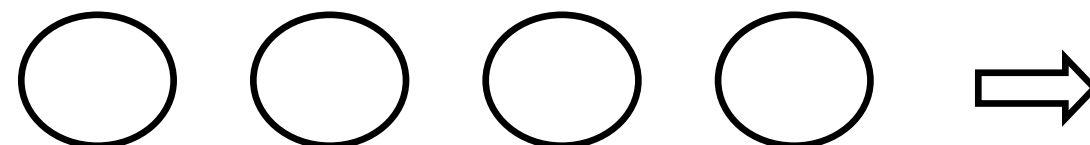
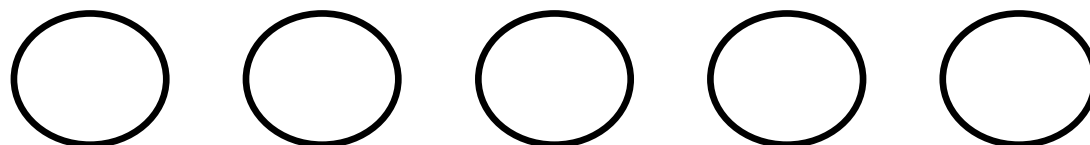
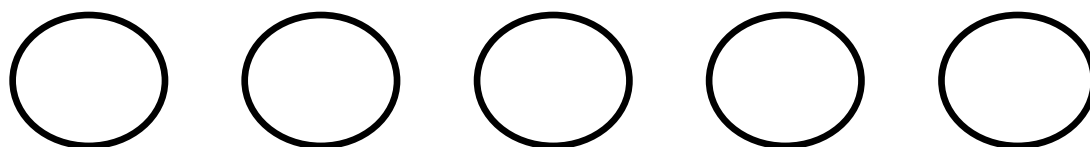
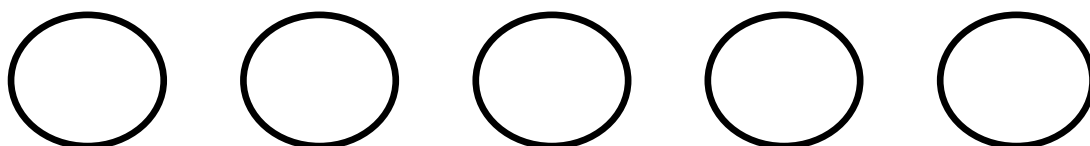
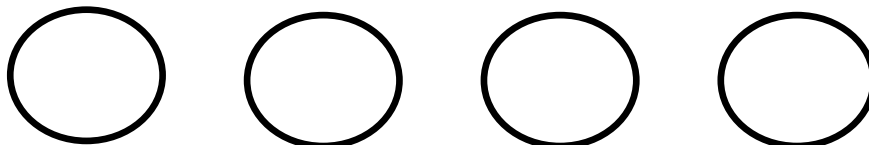
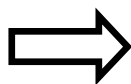
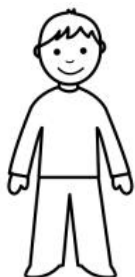

Actividades para mejorar la psicomotricidad

Sigue los círculos para unir al niño con su balón

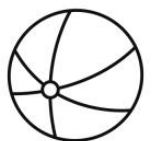
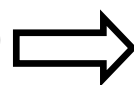
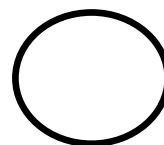
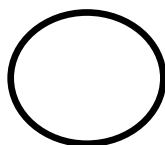
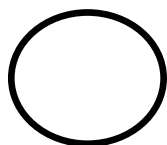
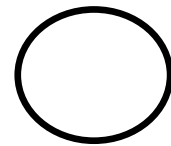
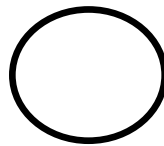
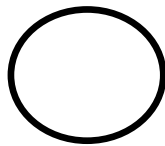
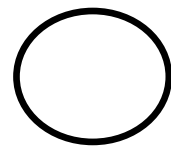
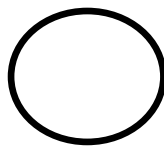
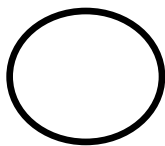
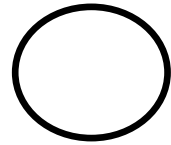
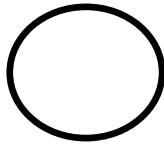
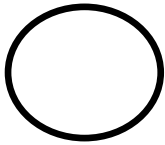
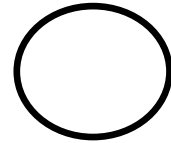
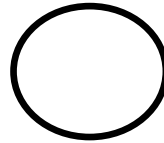
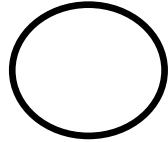
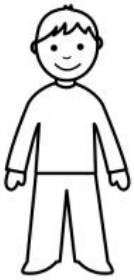

Actividades para mejorar la psicomotricidad

Sigue los rayos para unir la nube con la tierra

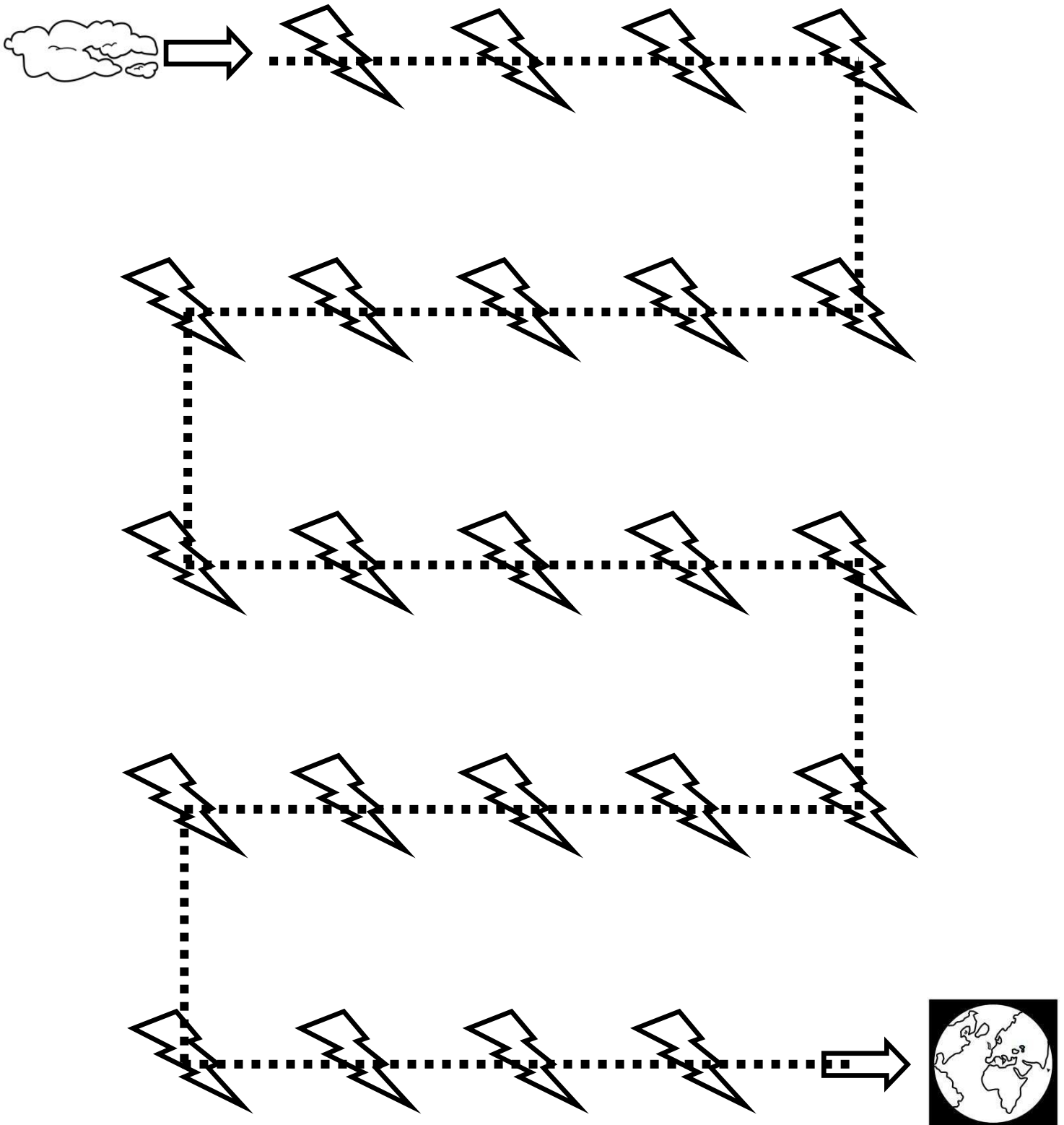

Actividades para mejorar la psicomotricidad

Sigue las caras para unir al niño y a la niña

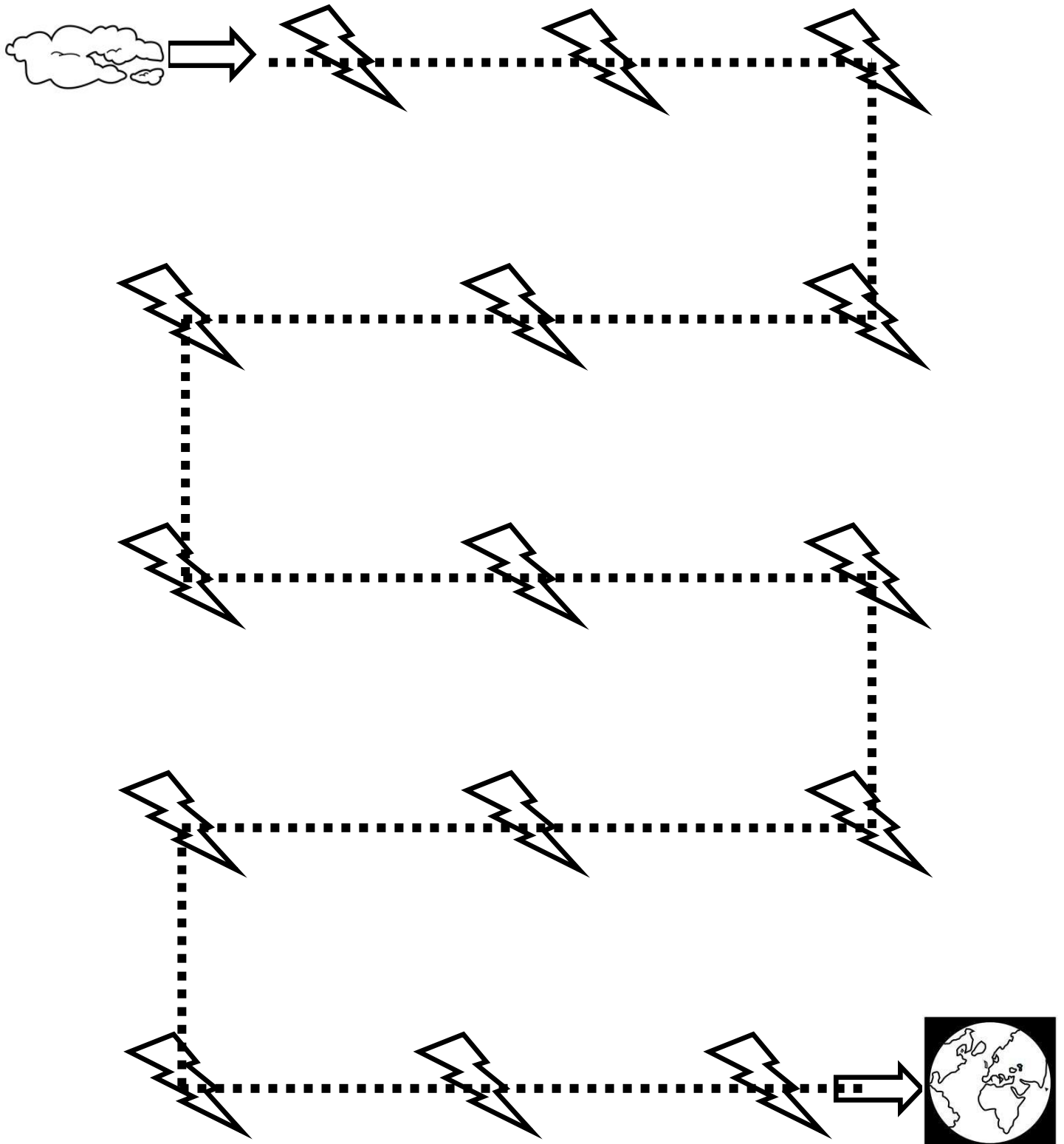

Actividades para mejorar la psicomotricidad

Sigue las caras para unir al niño y a la niña

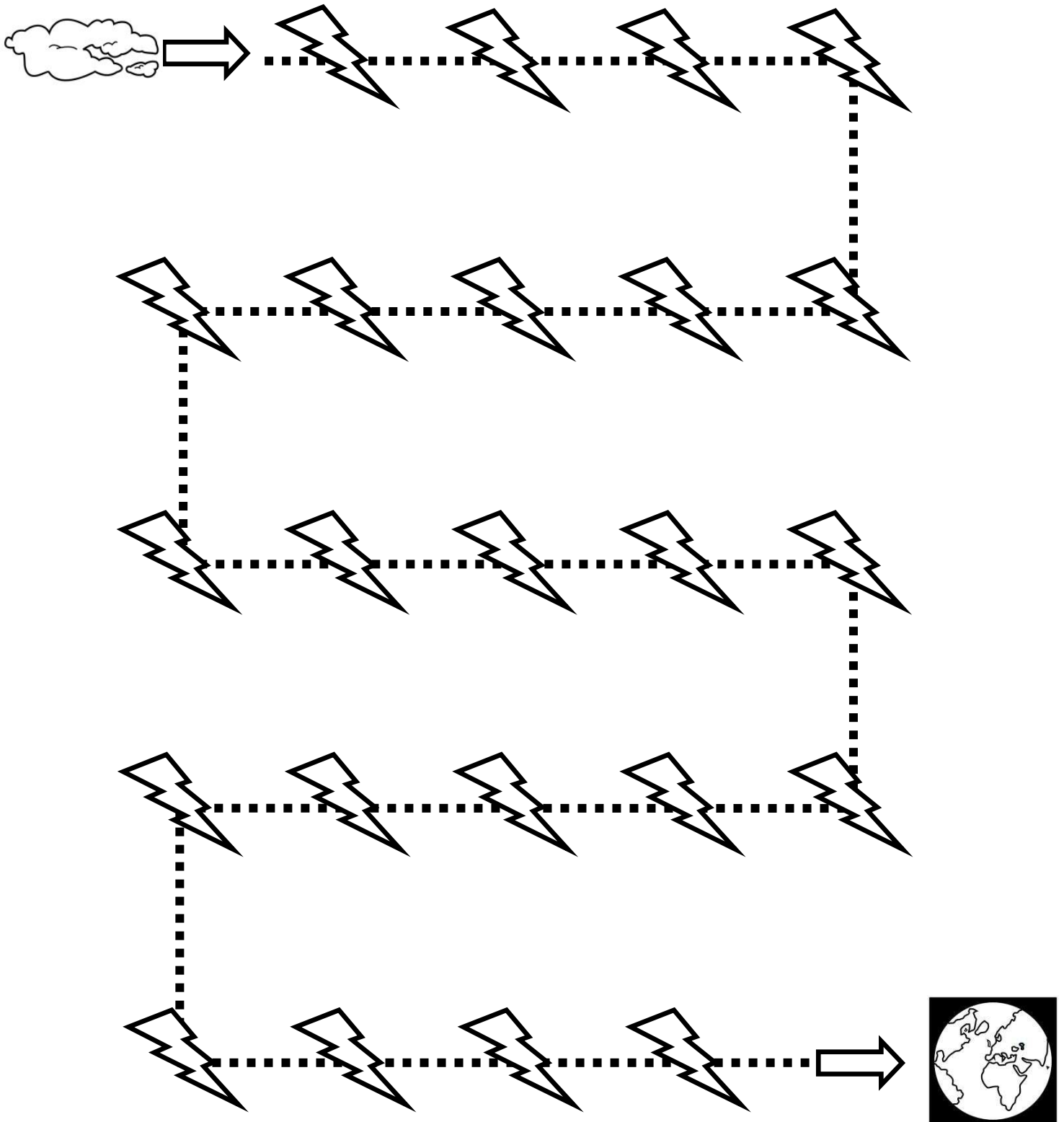

Actividades para mejorar la psicomotricidad

Sigue las caras para unir al niño y a la niña

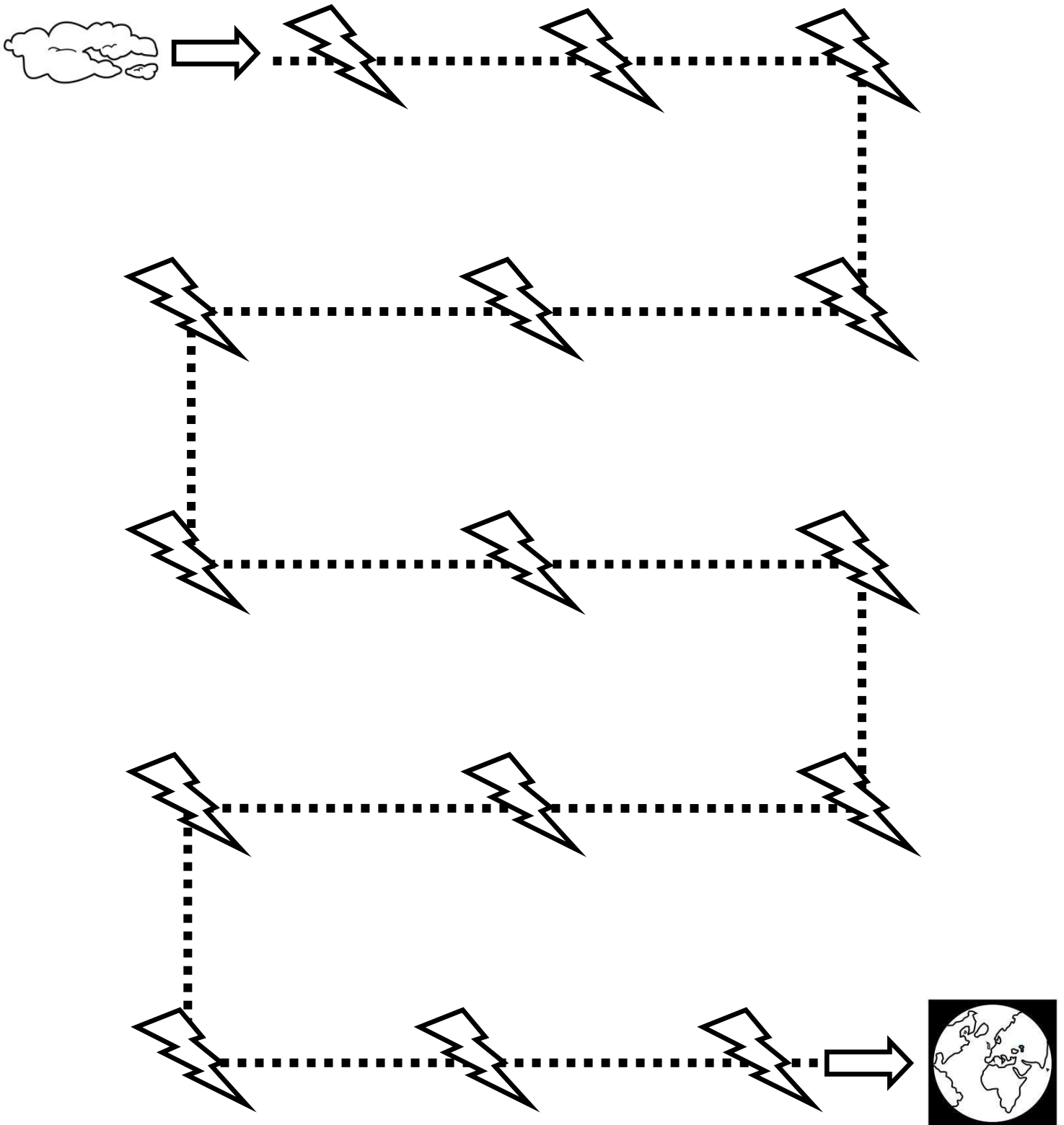

Actividades para mejorar la psicomotricidad

Sigue las caras para unir al niño y a la niña

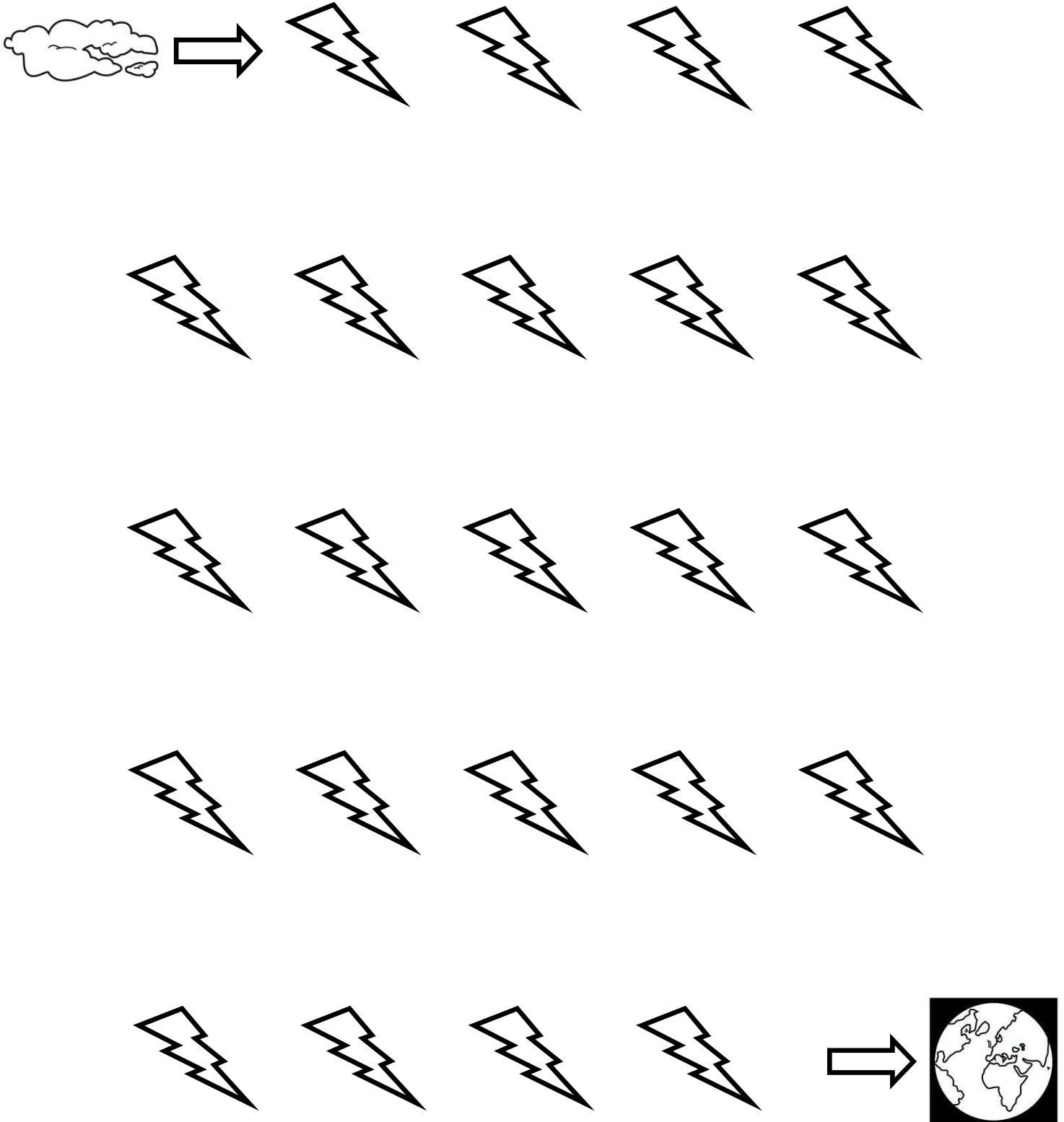

Actividades para mejorar la psicomotricidad

Sigue las caras para unir al niño y a la niña

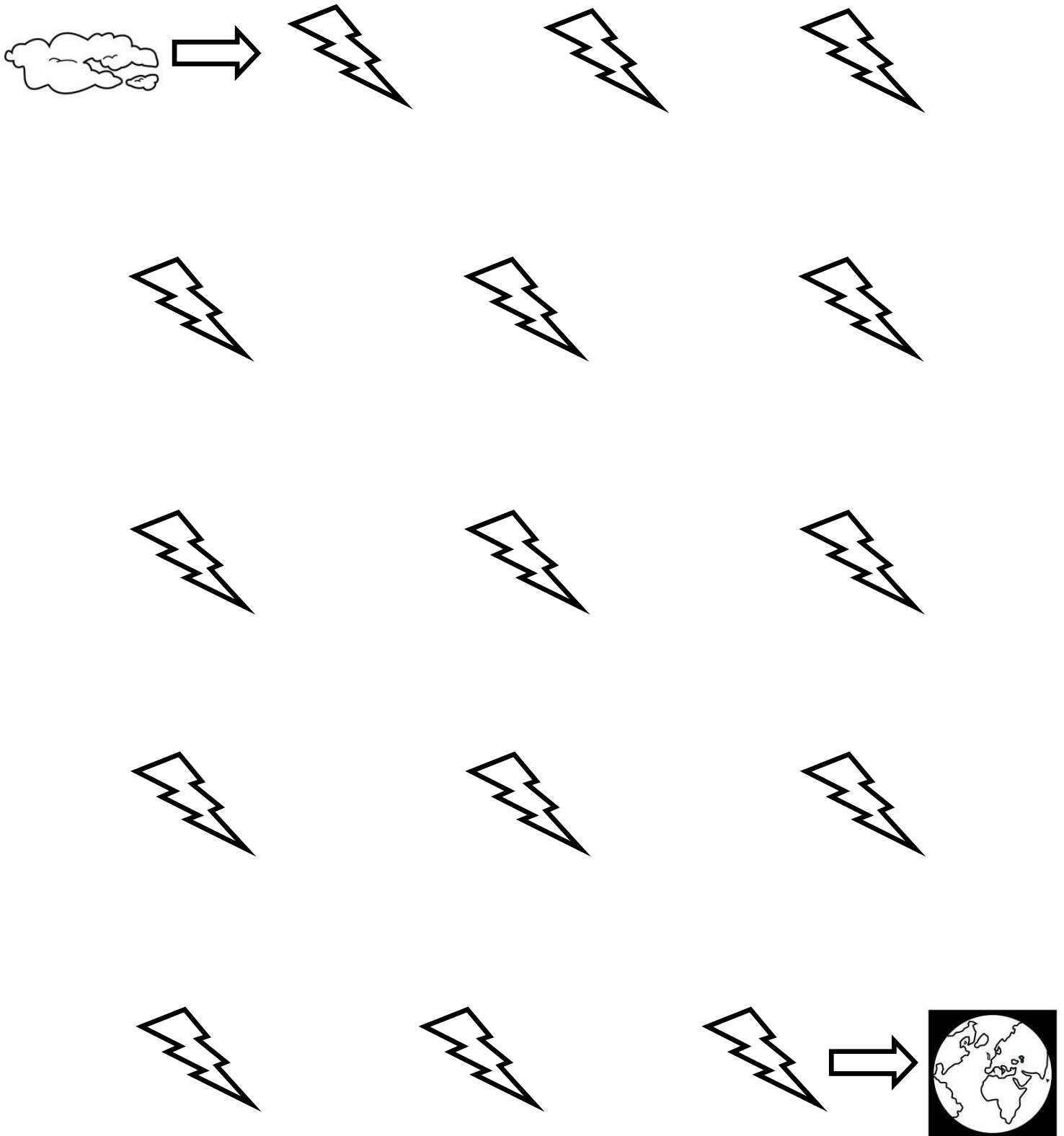

Actividades para mejorar la psicomotricidad

Sigue las estrellitas para ir desde el sol a la tierra

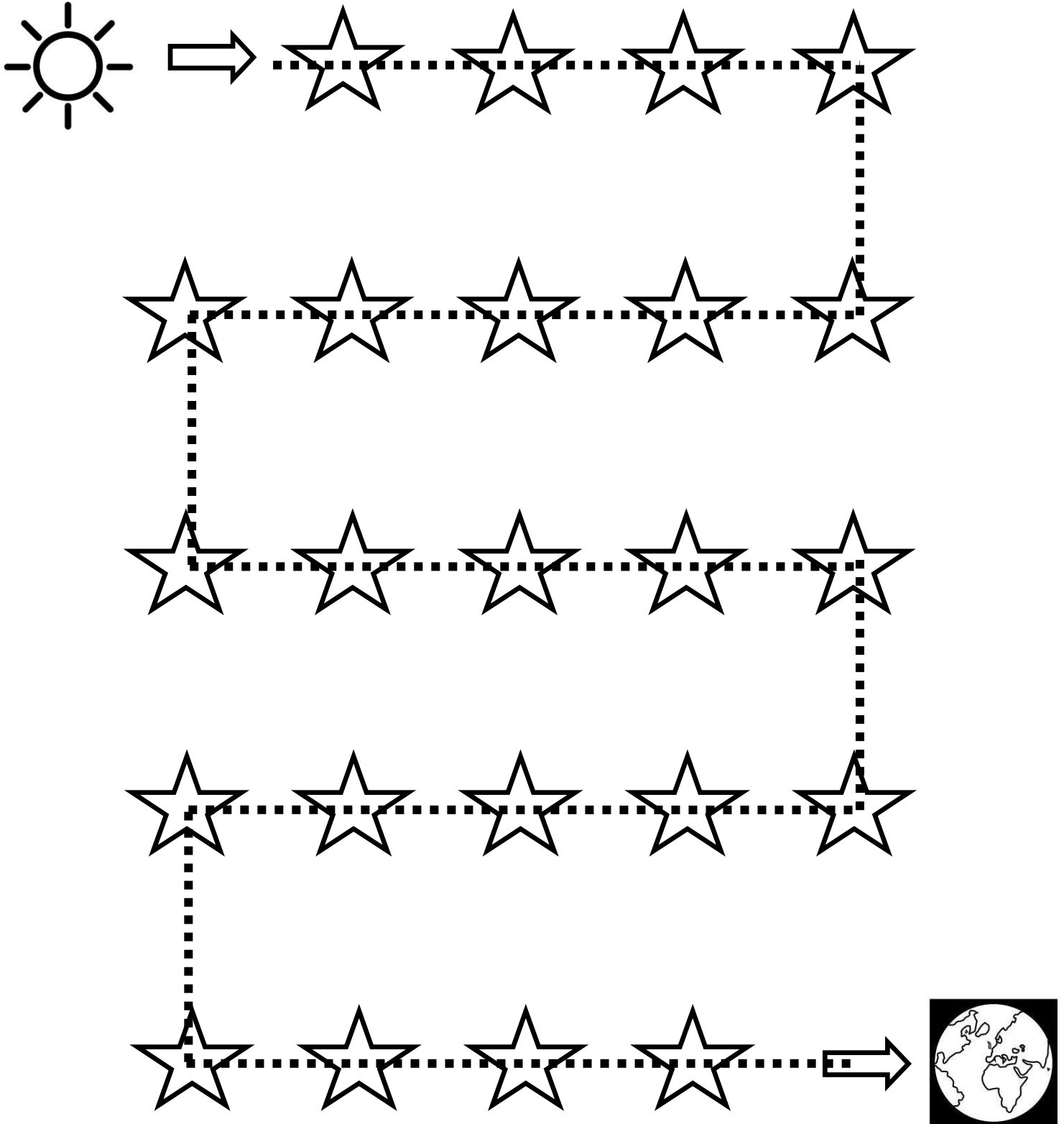

Actividades para mejorar la psicomotricidad

Sigue las estrellitas para ir desde el sol a la tierra

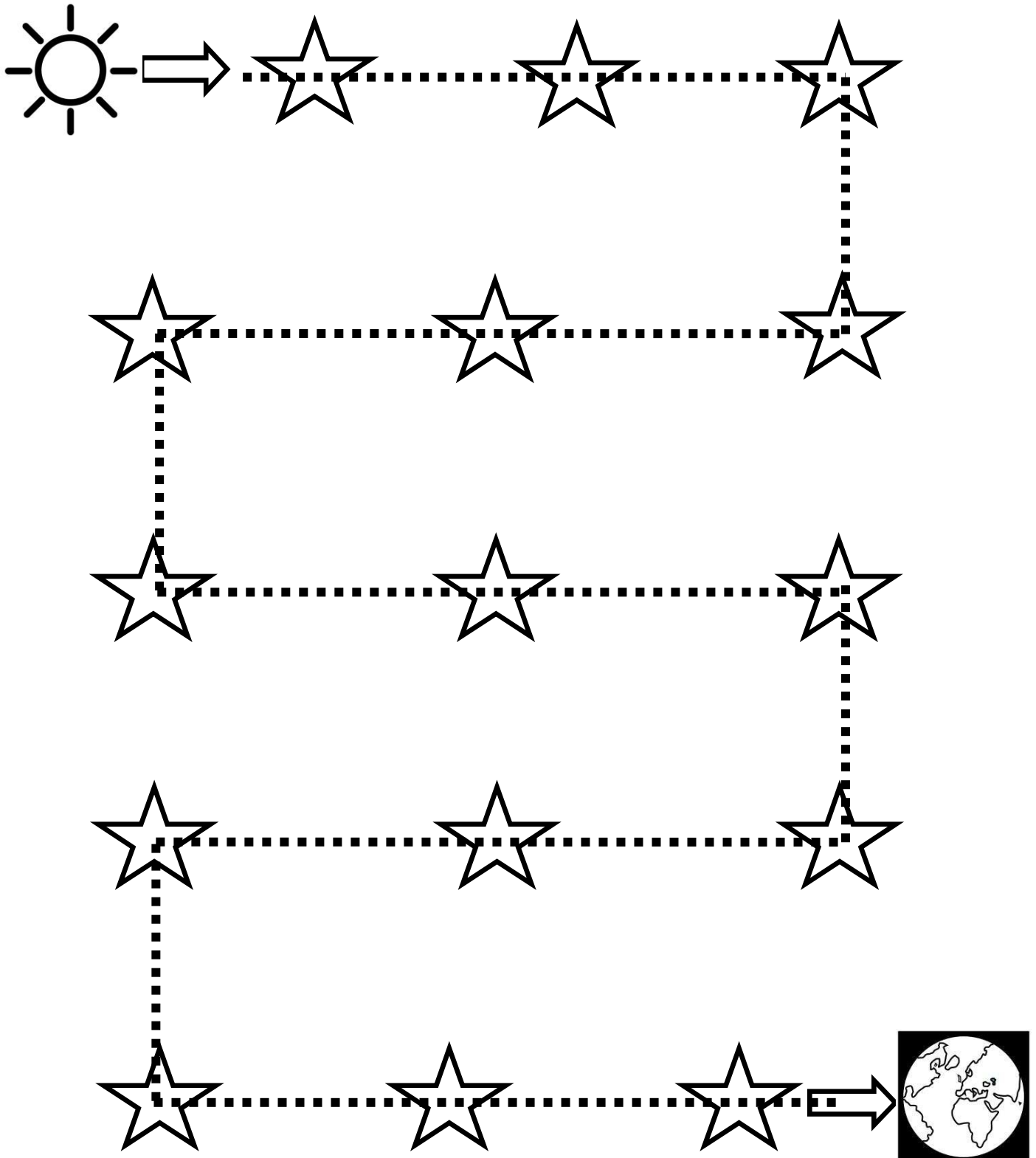

Actividades para mejorar la psicomotricidad

Sigue las estrellitas para ir desde el sol a la tierra

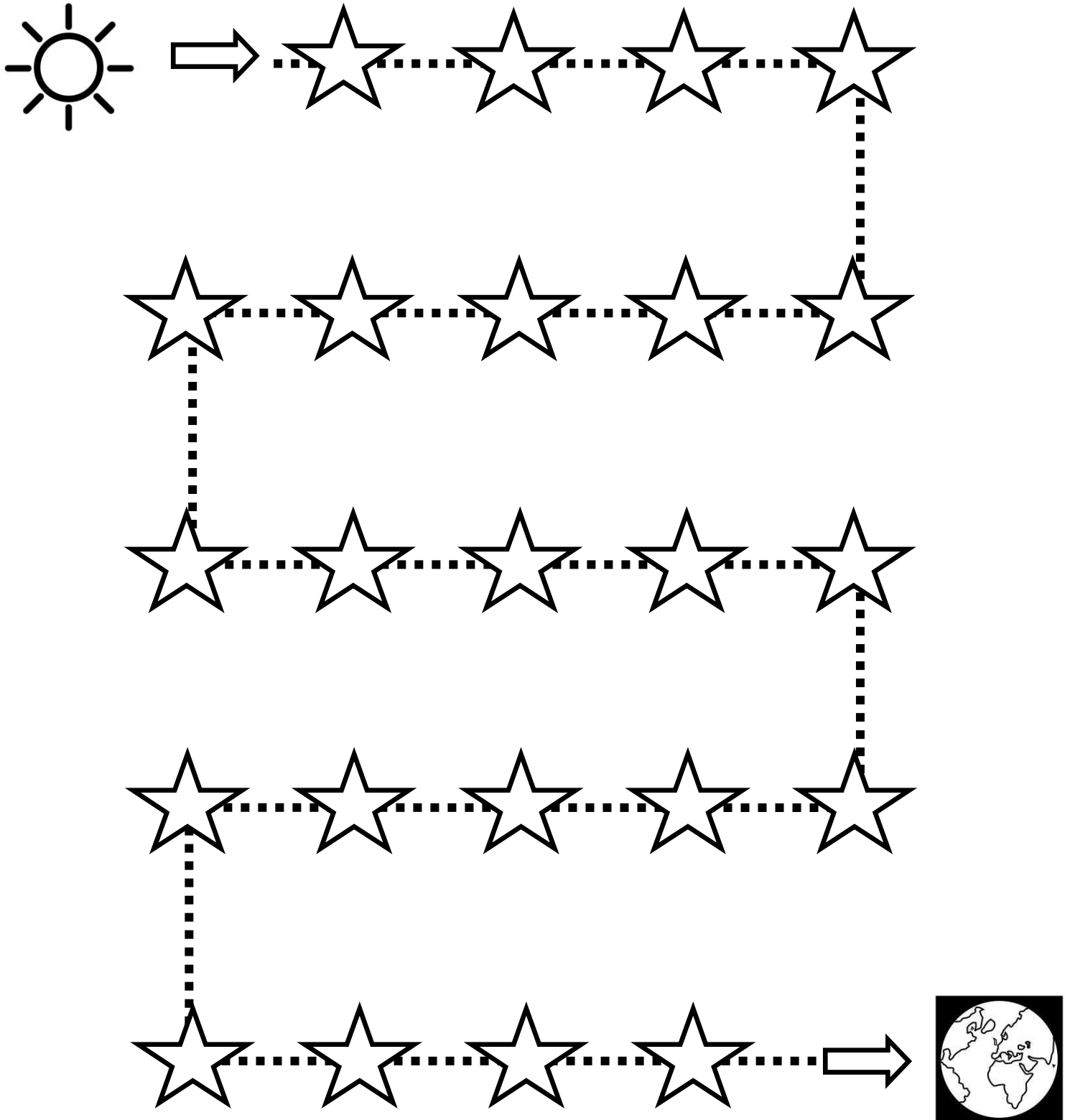

Actividades para mejorar la psicomotricidad

Sigue las estrellitas para ir desde el sol a la tierra

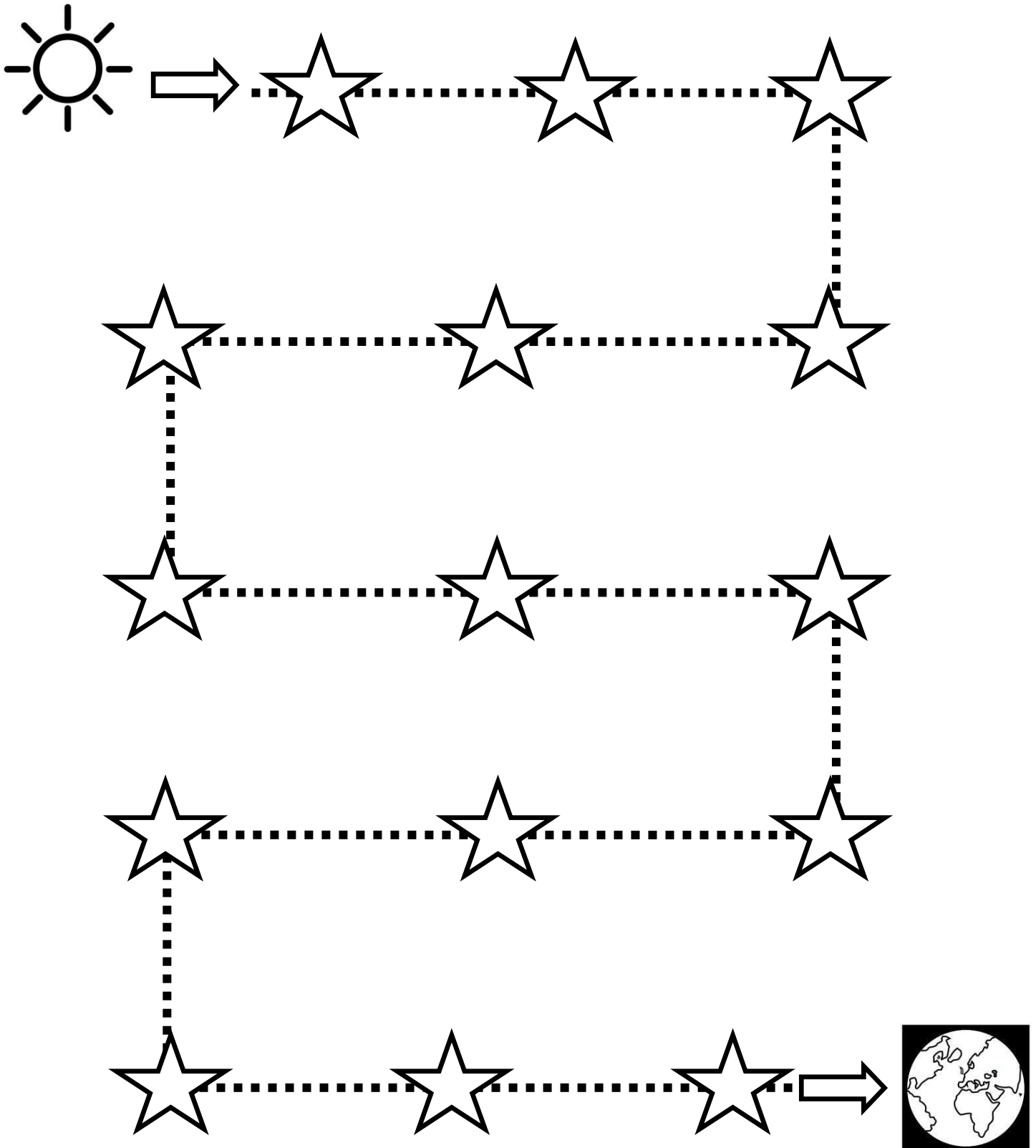

Actividades para mejorar la psicomotricidad

Sigue las estrellitas para ir desde el sol a la tierra

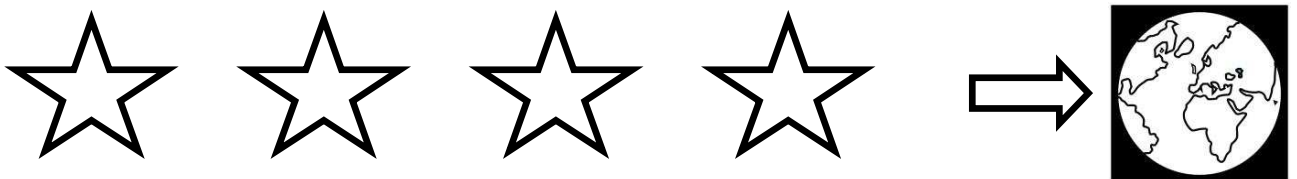
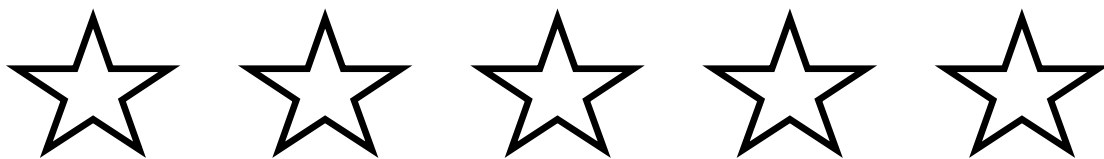
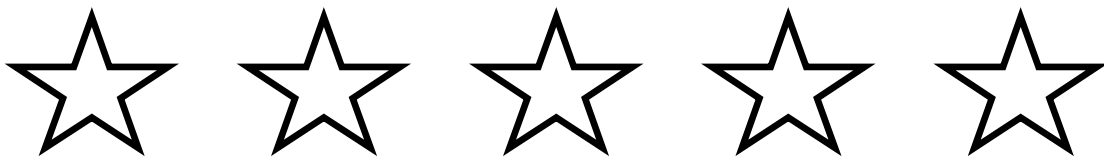
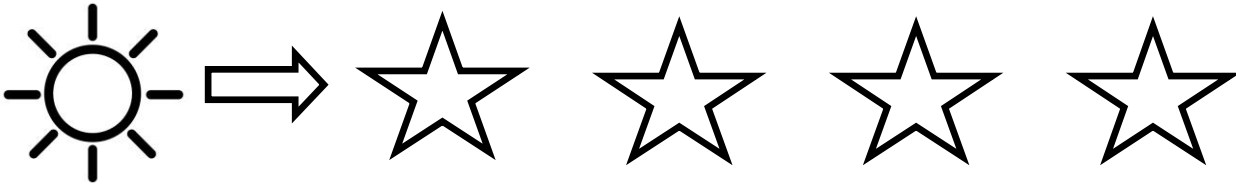

Actividades para mejorar la psicomotricidad

Sigue las estrellitas para ir desde el sol a la tierra

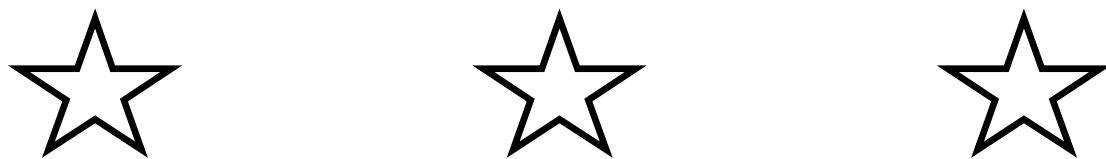
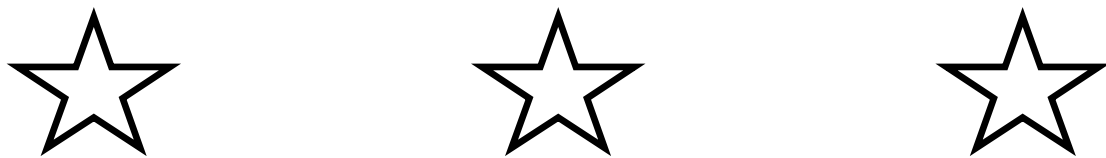

Actividades para mejorar motricidad fina

Sigue con tu lápiz las estrellitas para ir desde el sol a la tierra

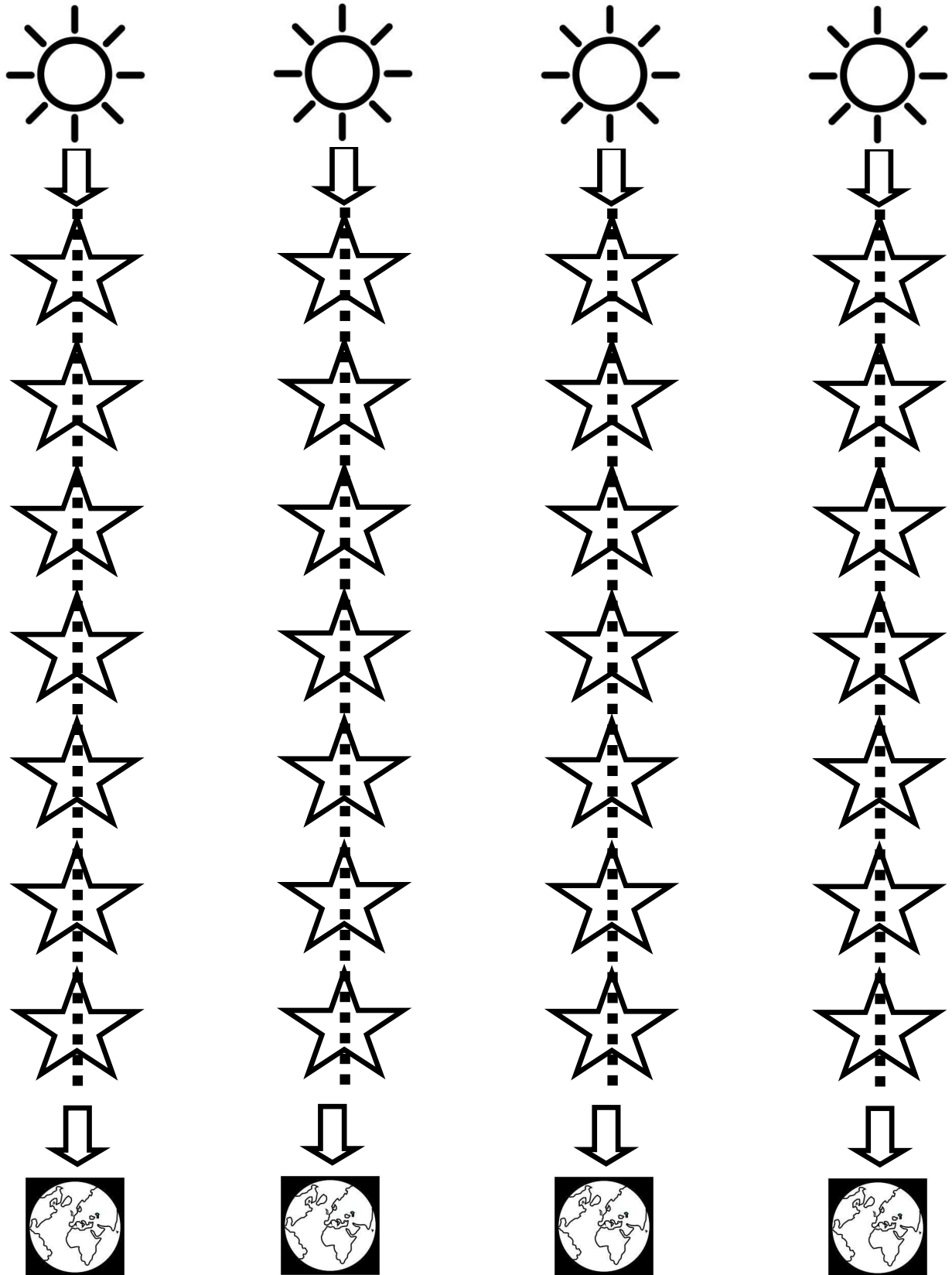

Actividades para mejorar motricidad fina

Sigue con tu lápiz las estrellitas para ir desde el sol a la tierra

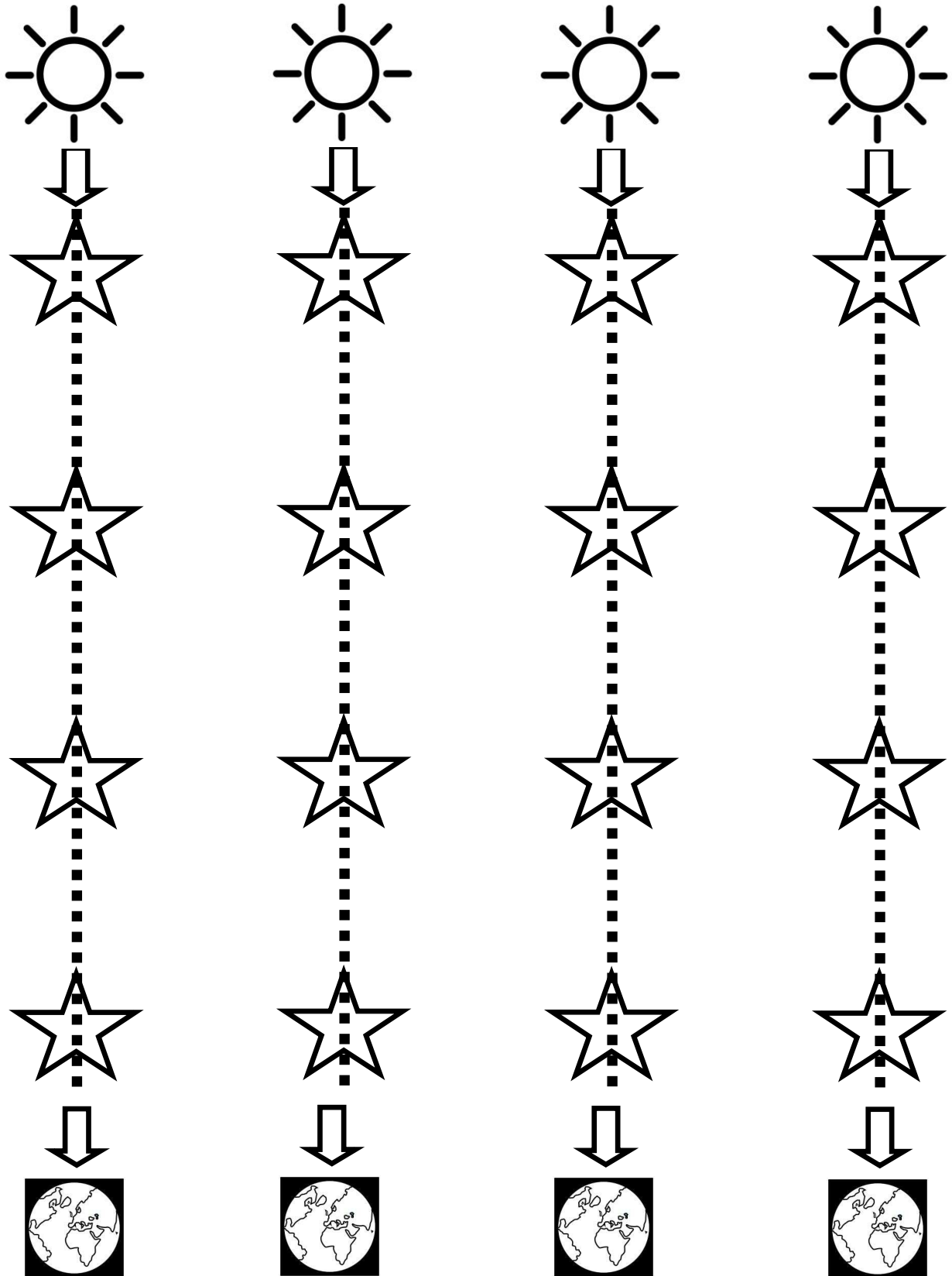

Actividades para mejorar motricidad fina

Sigue con tu lápiz las estrellitas para ir desde el sol a la tierra

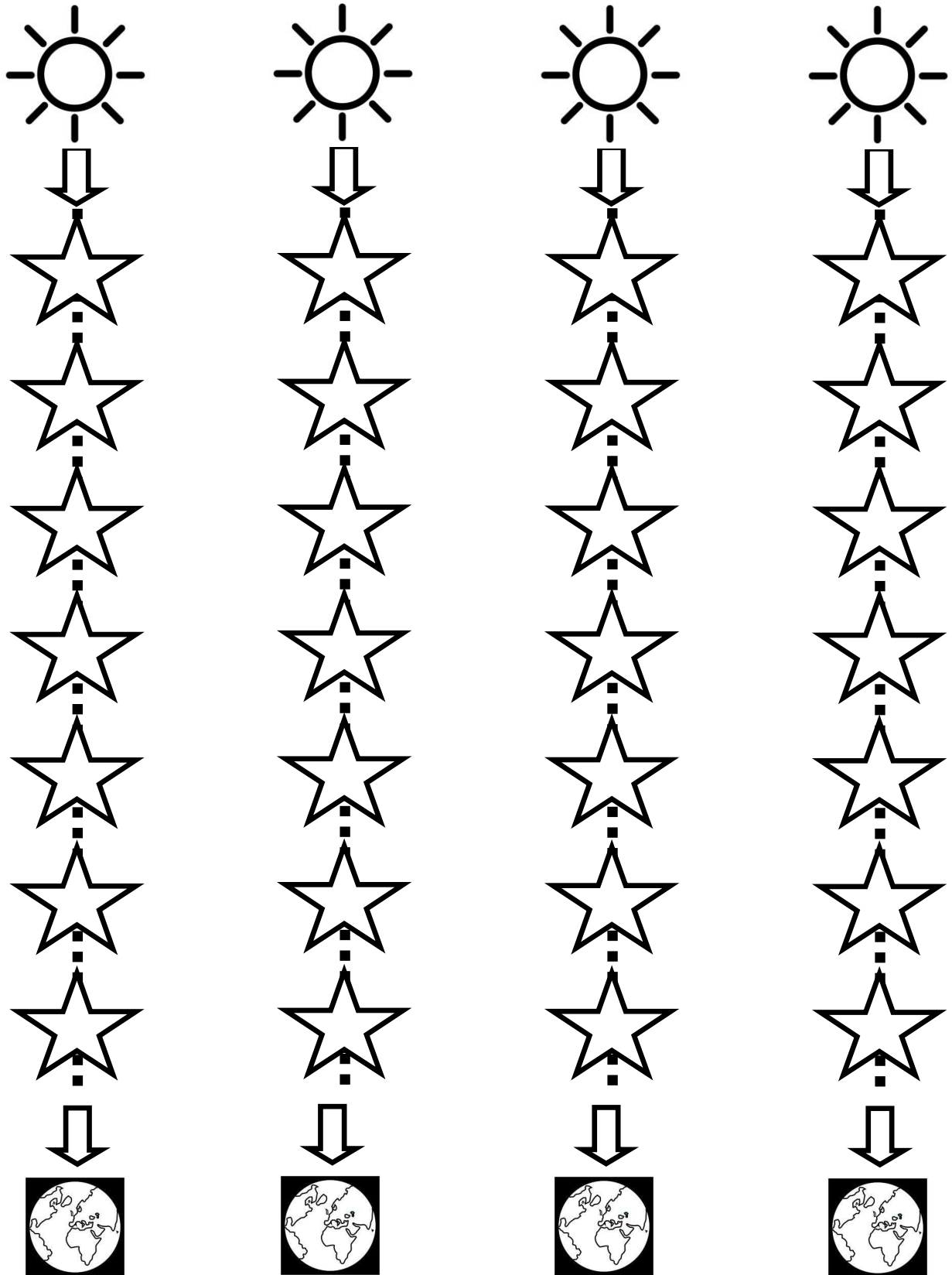

Actividades para mejorar motricidad fina

Sigue con tu lápiz las estrellitas para ir desde el sol a la tierra

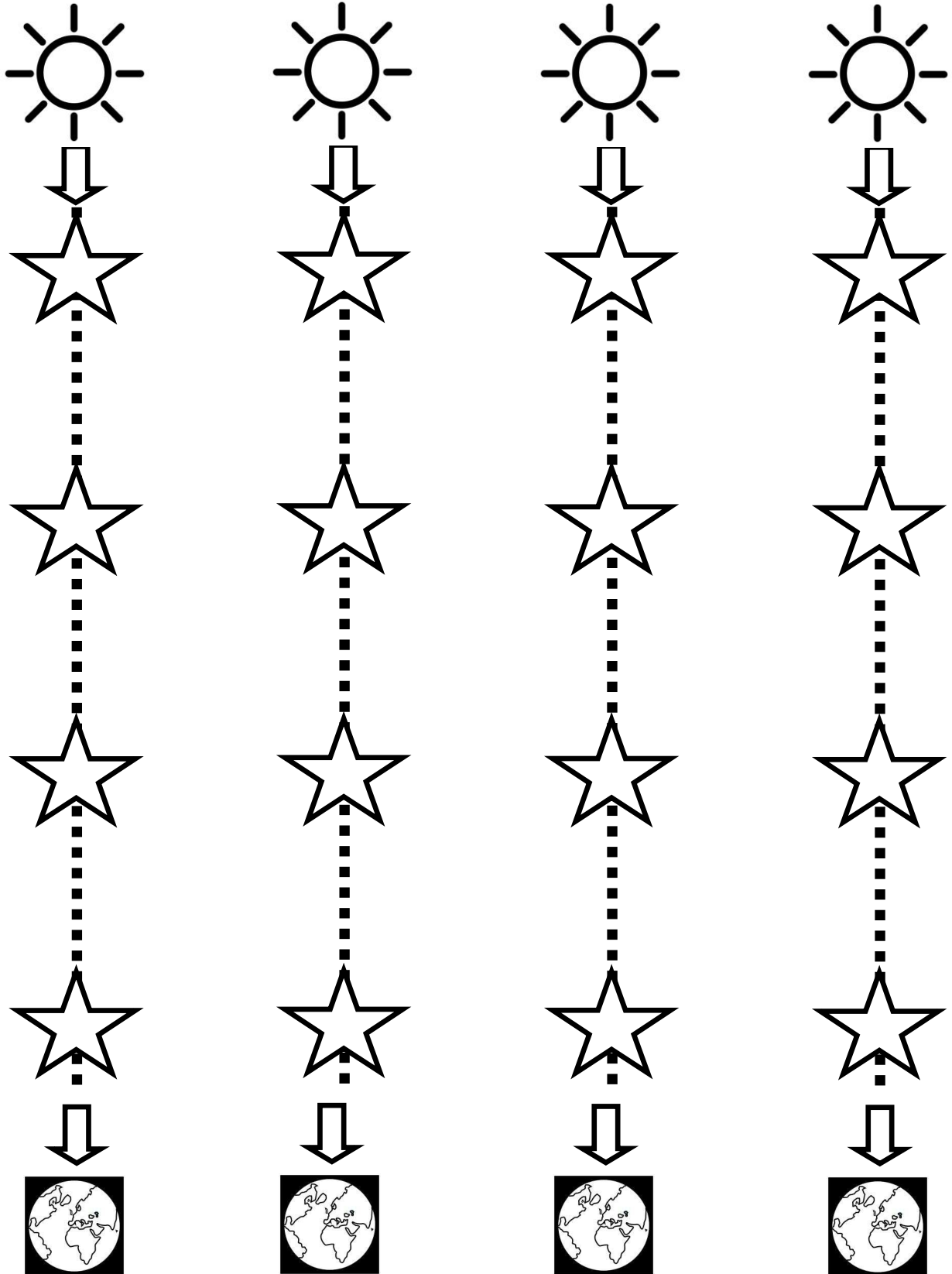

Actividades para mejorar motricidad fina

Sigue con tu lápiz las estrellitas para ir desde el sol a la tierra

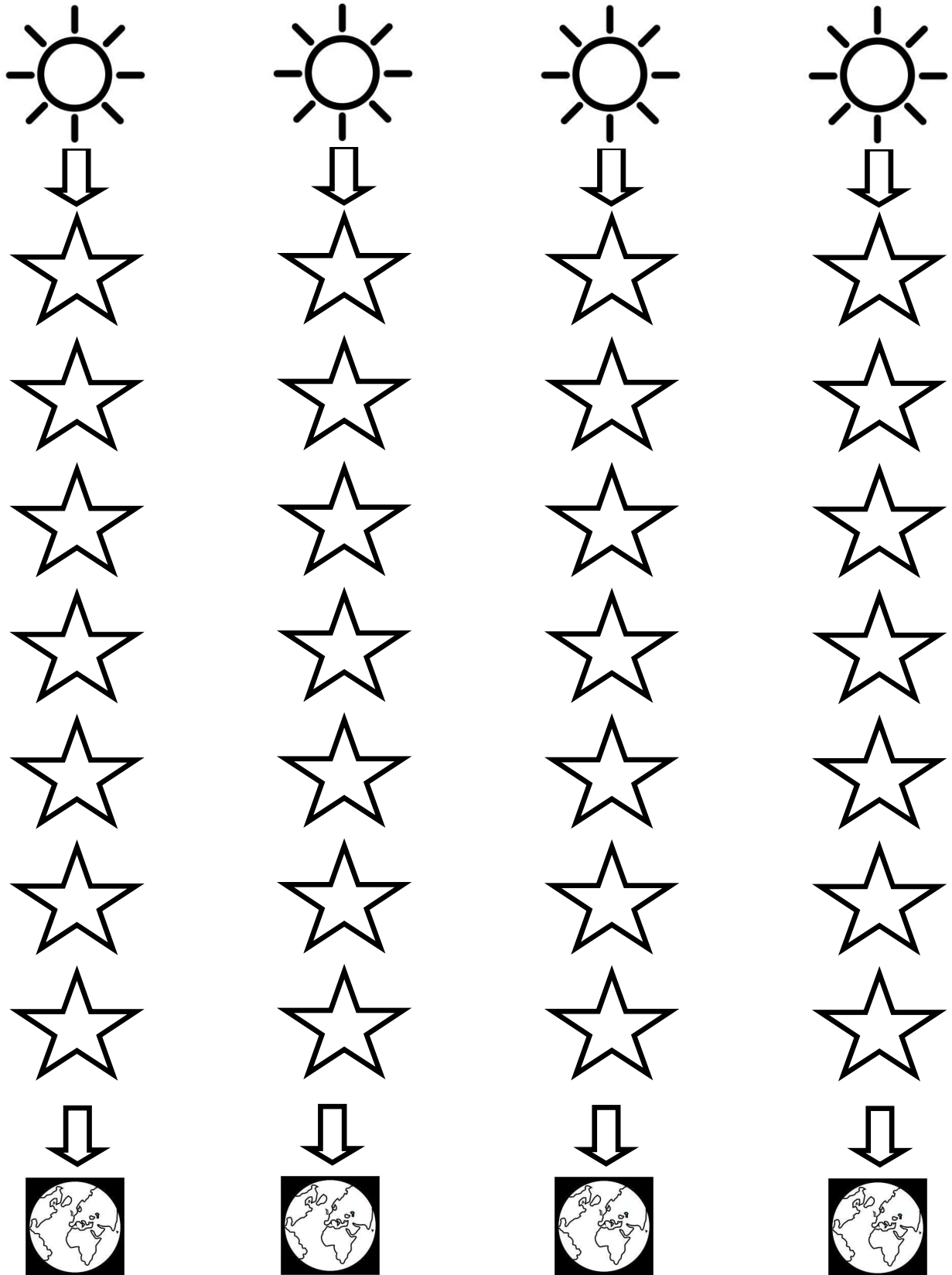

Actividades para mejorar motricidad fina

Sigue con tu lápiz las estrellitas para ir desde el sol a la tierra

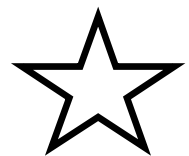
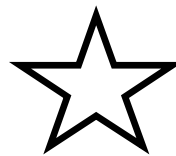
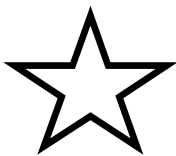
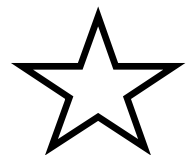
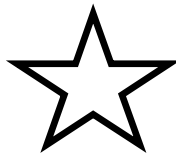
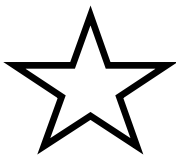
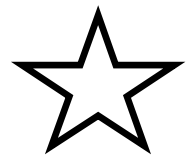
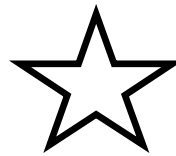
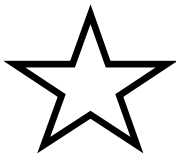
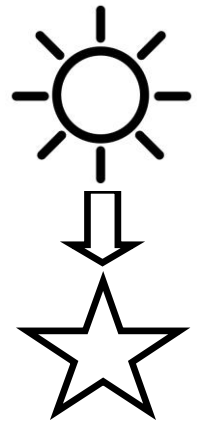
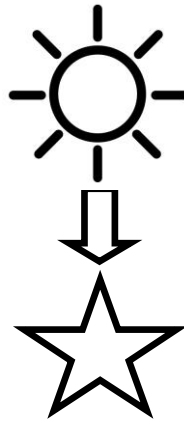
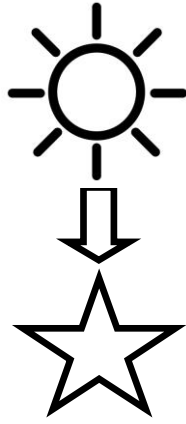
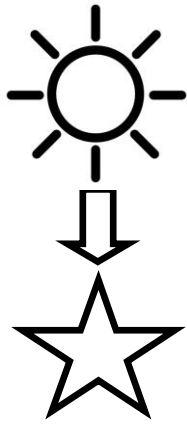

Actividades para mejorar motricidad fina

Sigue con tu lápiz los corazones para unir a la mama y a su bebe

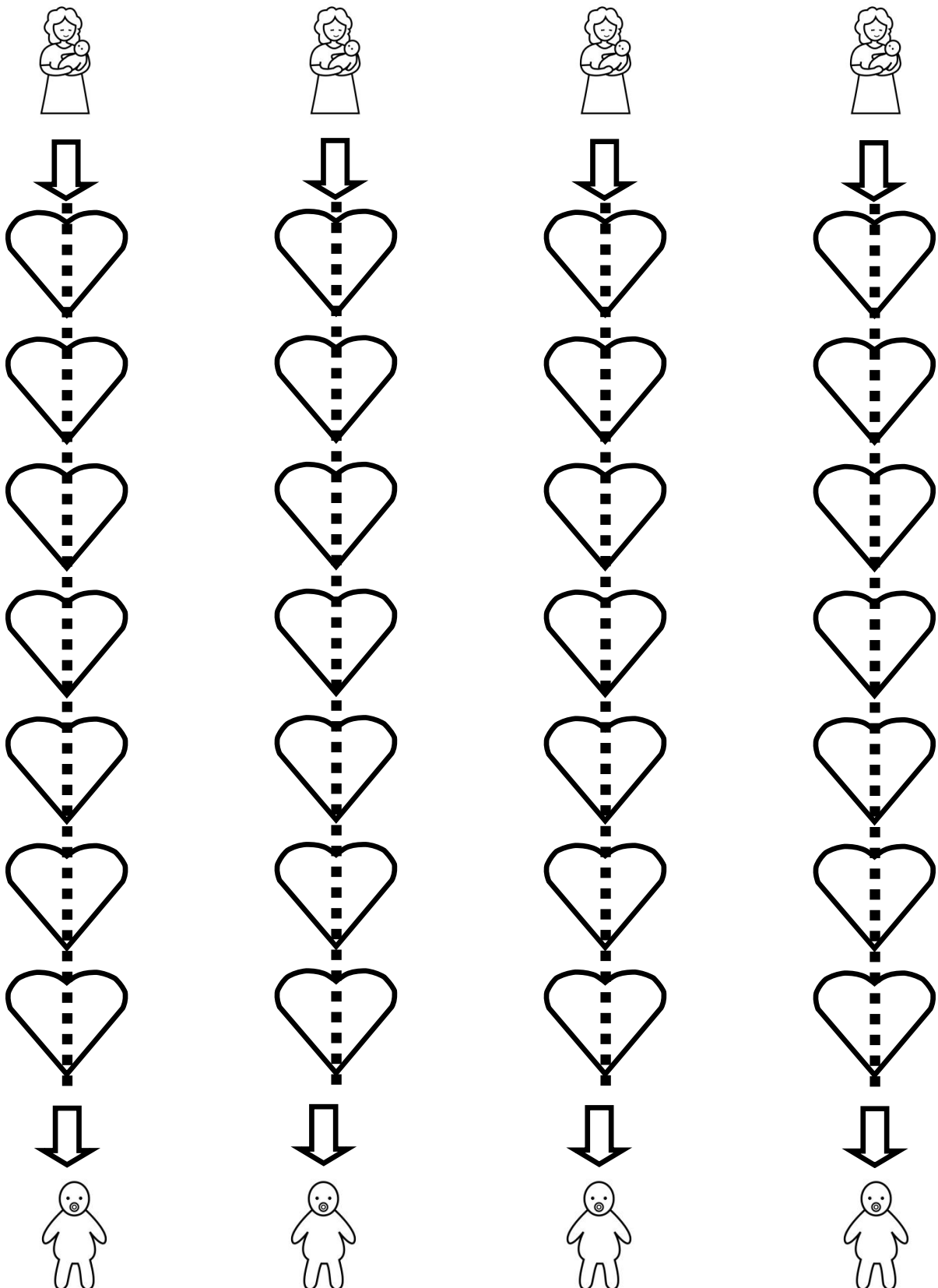

Actividades para mejorar motricidad fina

Sigue con tu lápiz los corazones para unir a la mama y a su bebe

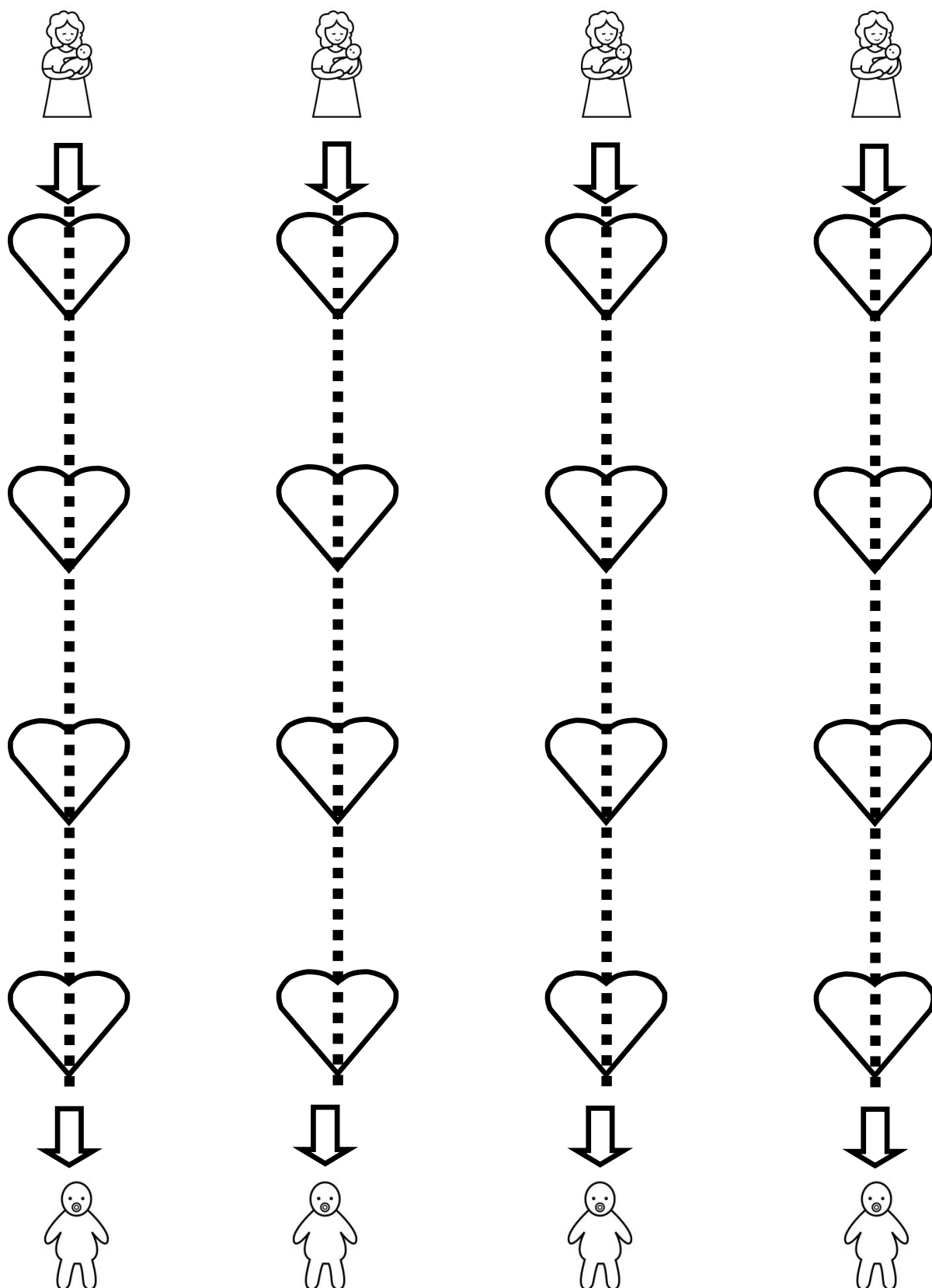

Actividades para mejorar motricidad fina

Sigue con tu lápiz los corazones para unir a la mama y a su bebe

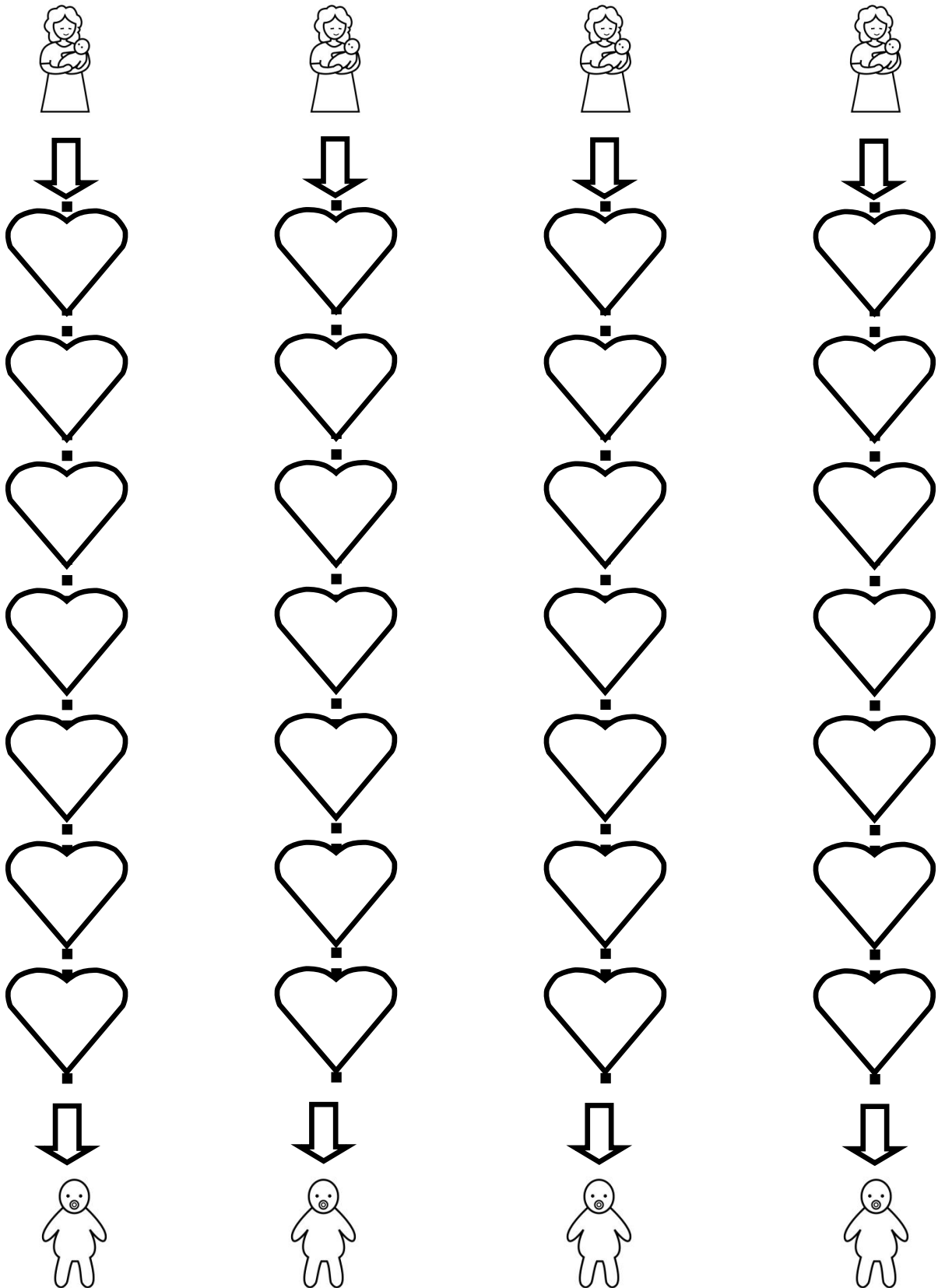

Actividades para mejorar motricidad fina

Sigue con tu lápiz los corazones para unir a la mama y a su bebe

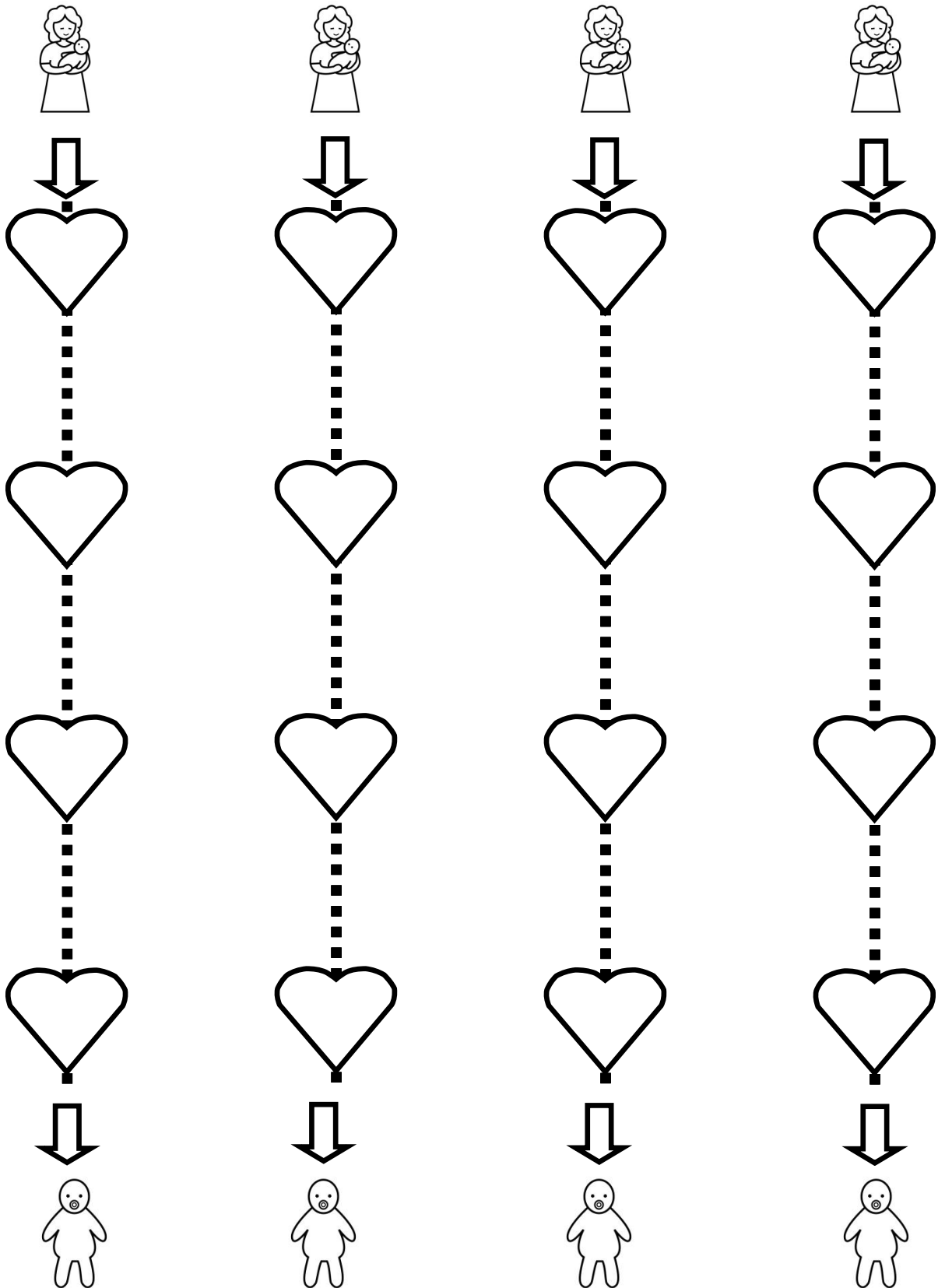

Actividades para mejorar motricidad fina

Sigue con tu lápiz los corazones para unir a la mama y a su bebe

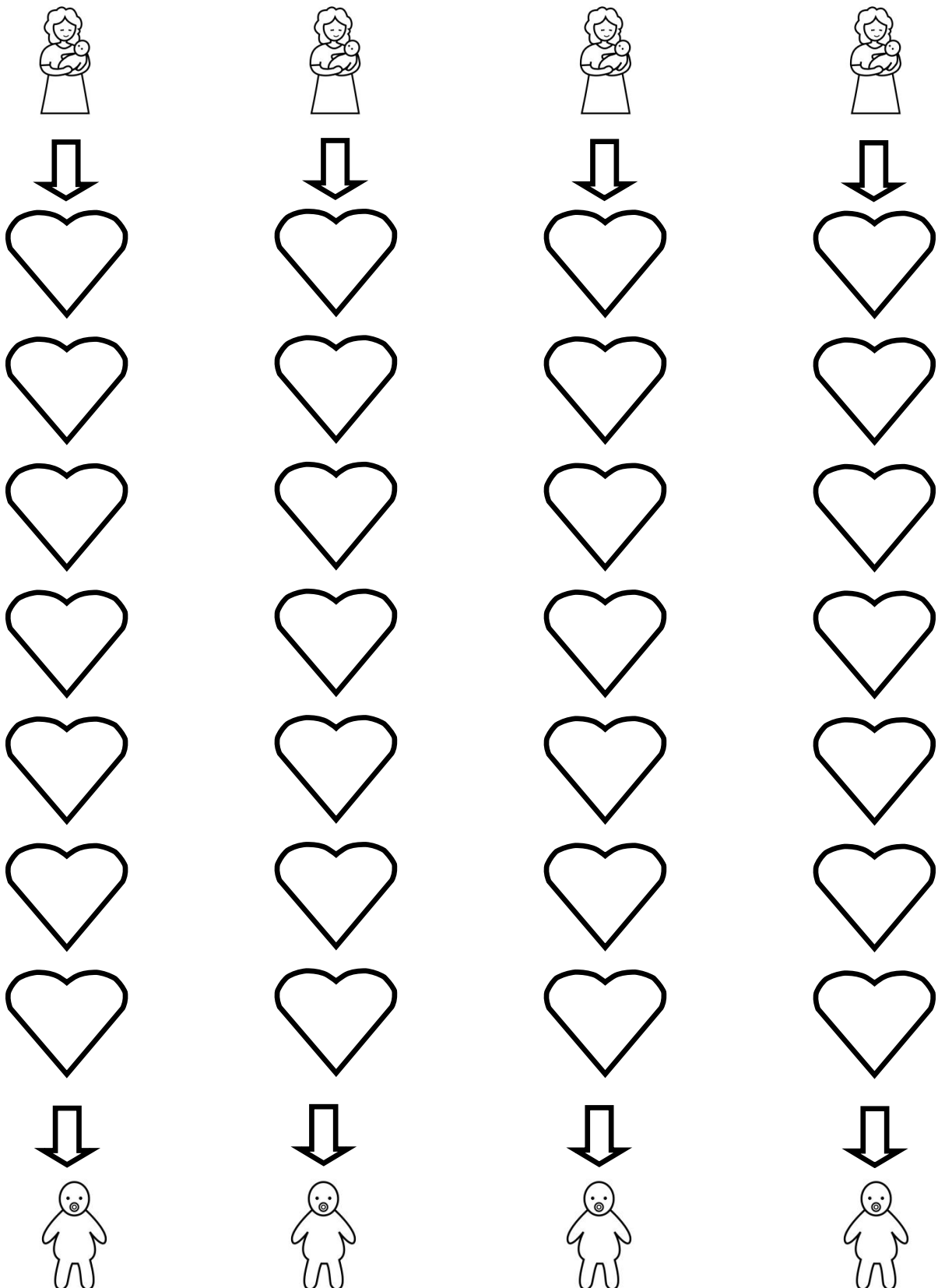

Actividades para mejorar motricidad fina

Sigue con tu lápiz los corazones para unir a la mama y a su bebe

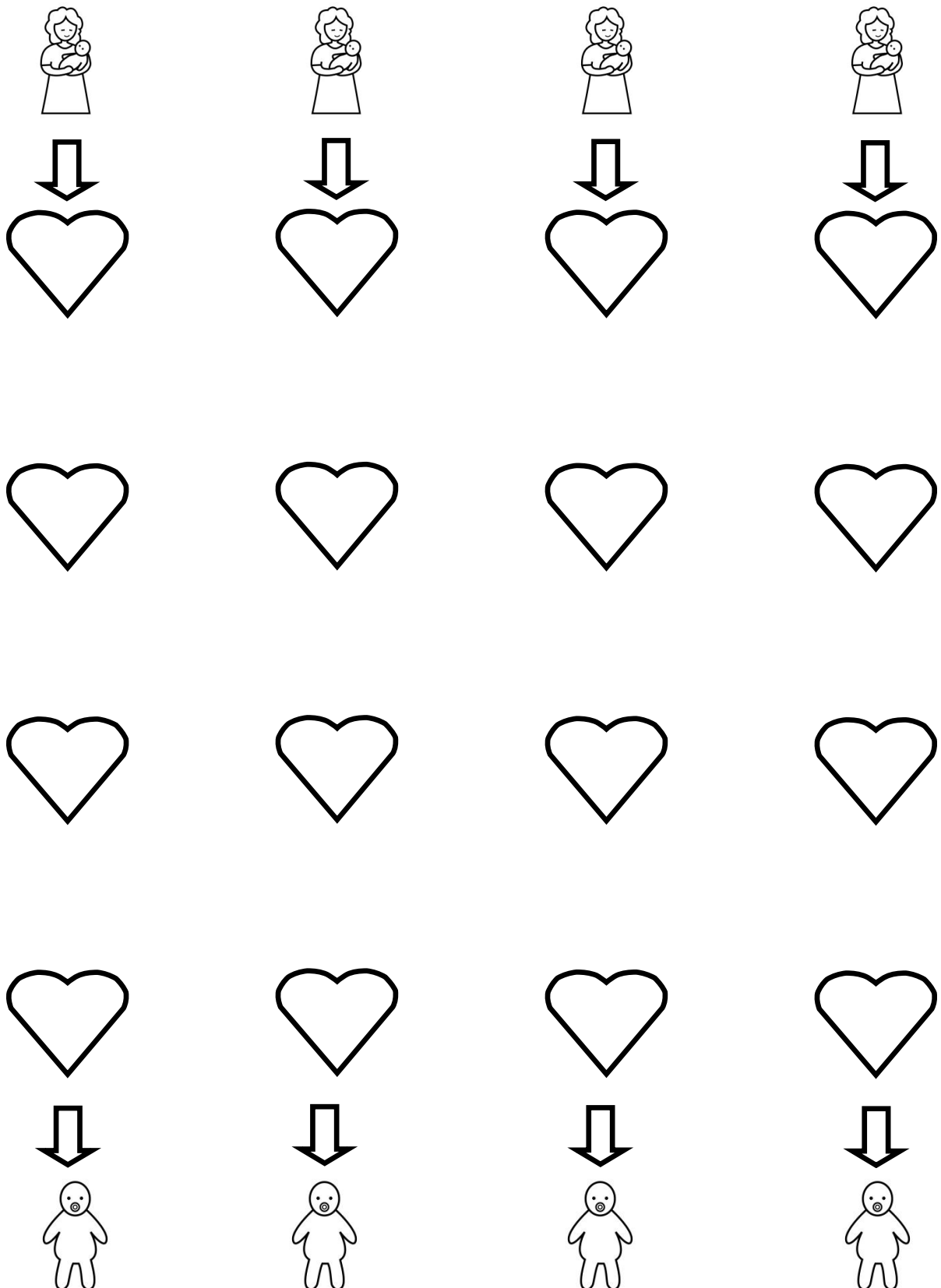

Actividades para mejorar motricidad fina

Sigue con tu lápiz las caras para unir al niño con su amiga

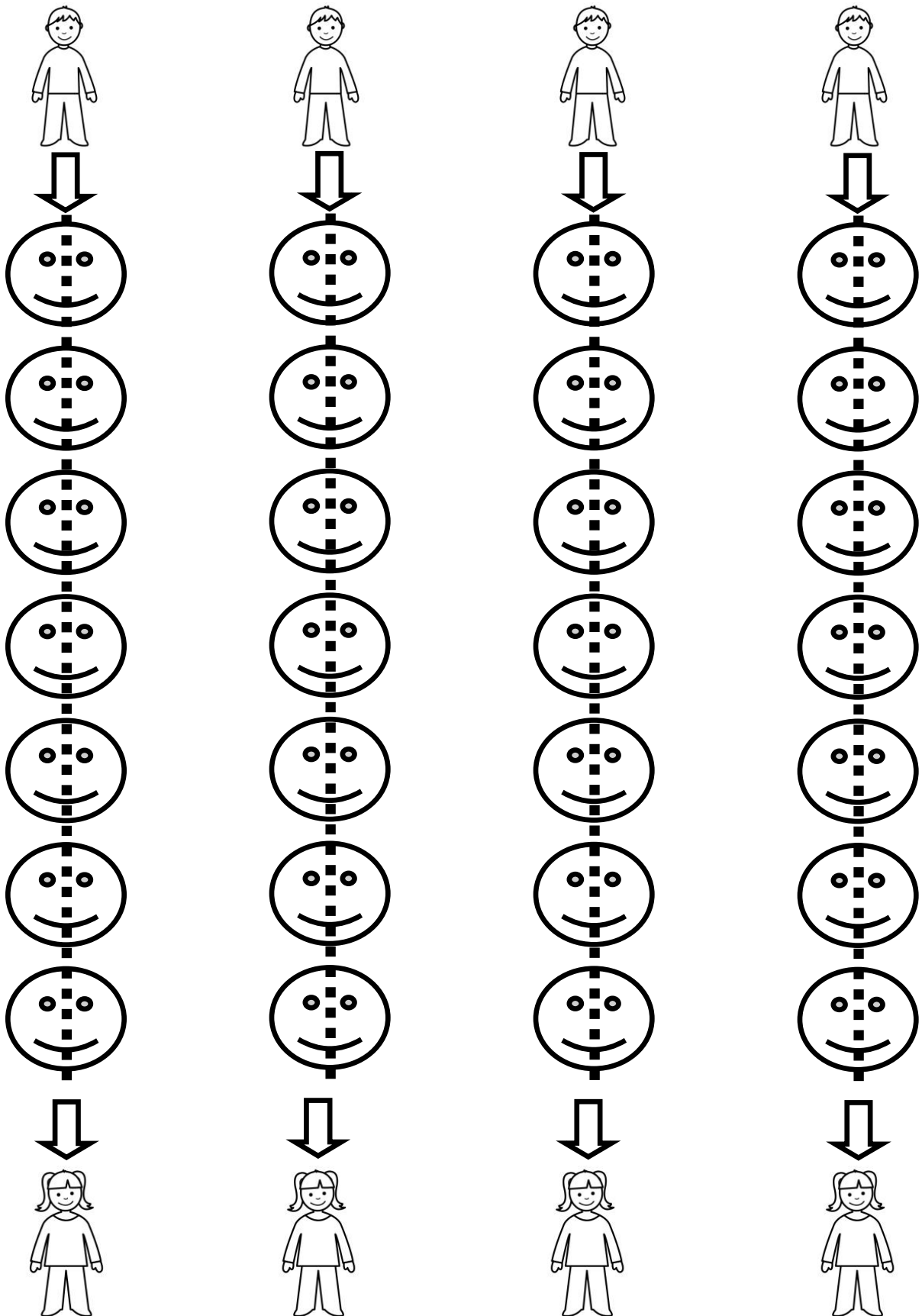

Actividades para mejorar motricidad fina

Sigue con tu lápiz caras para unir al niño con su amiga

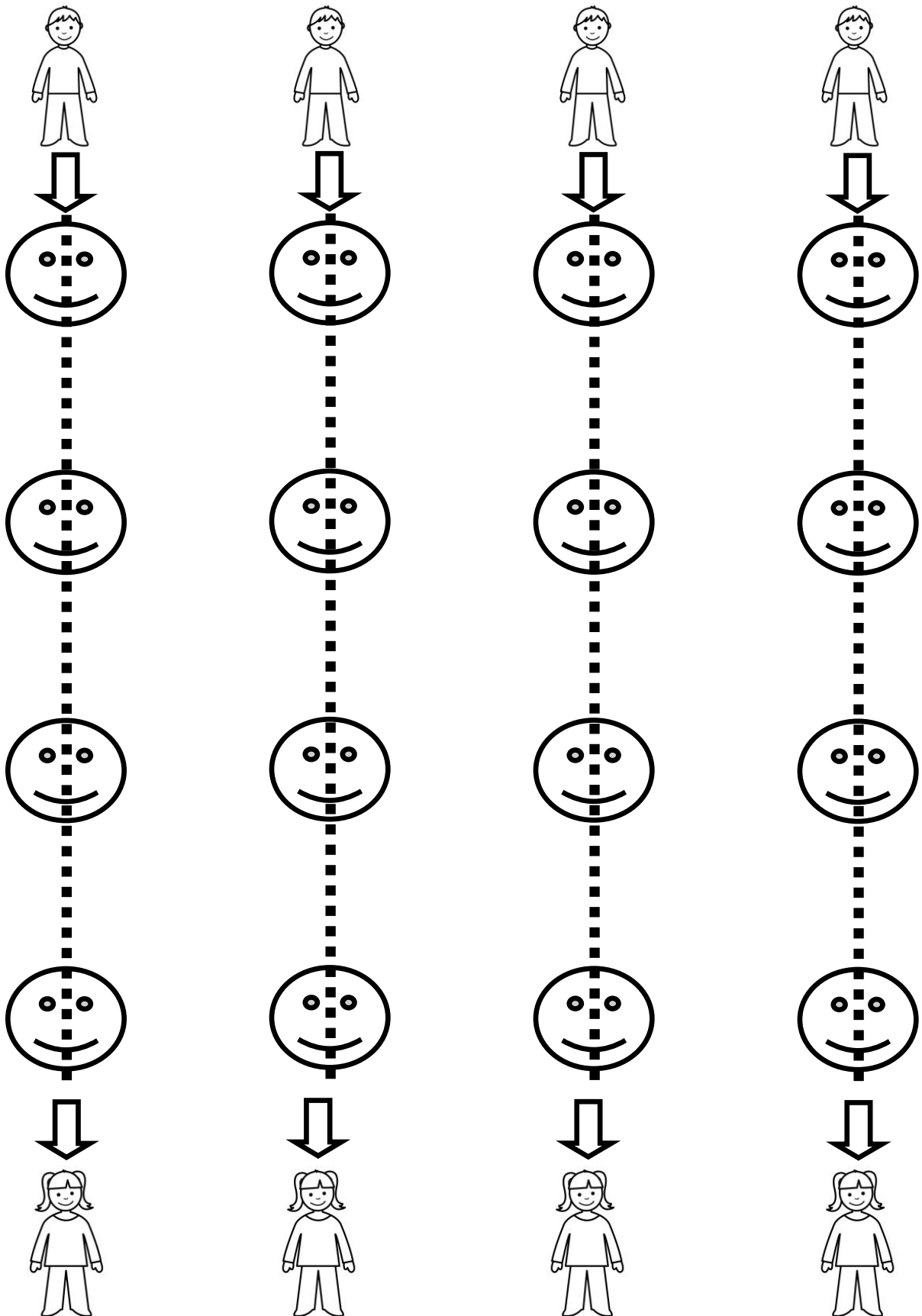

Actividades para mejorar motricidad fina

Sigue con tu lápiz caras para unir al niño con su amiga

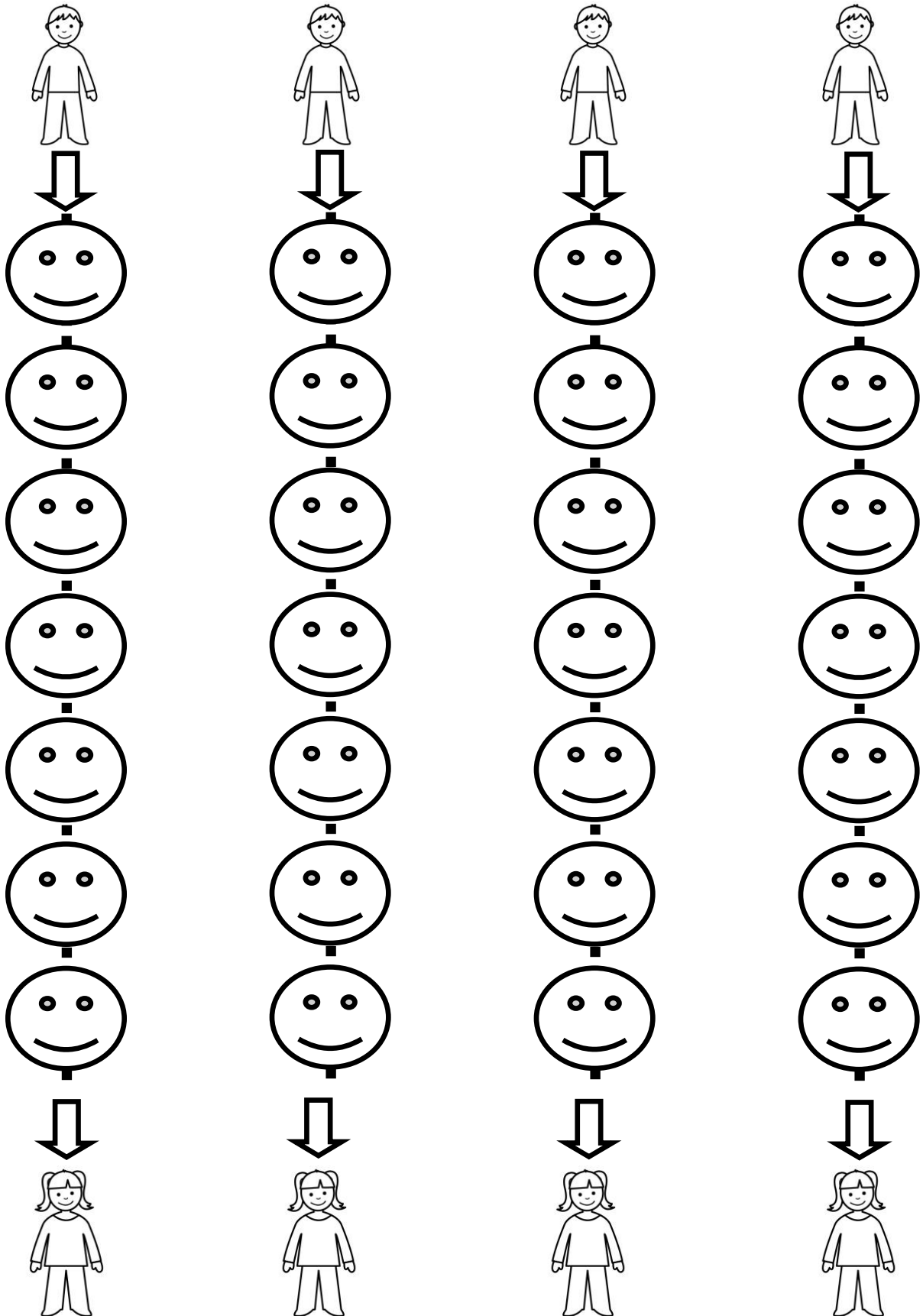

Actividades para mejorar motricidad fina

Sigue con tu lápiz caras para unir al niño con su amiga

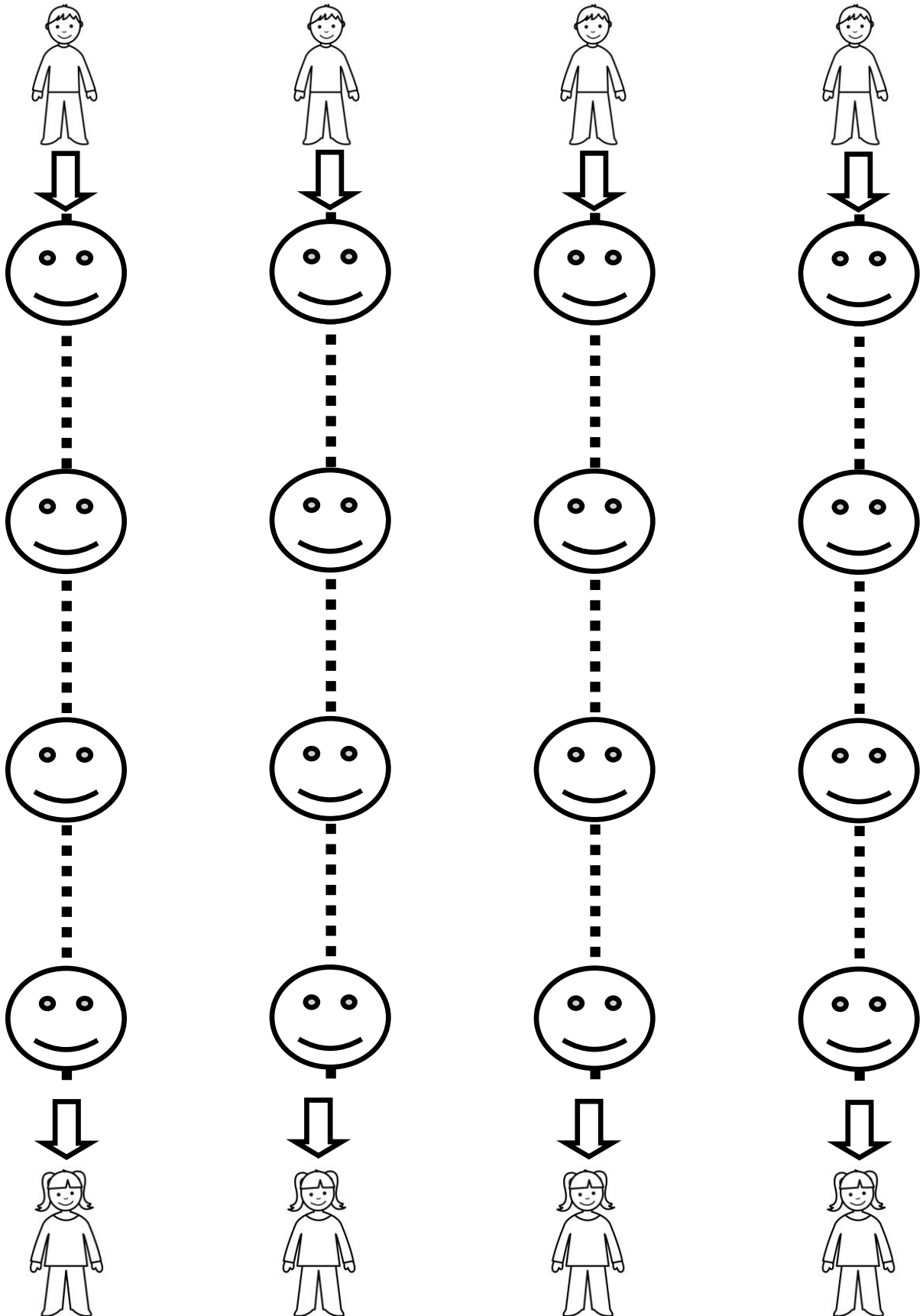

Actividades para mejorar motricidad fina

Sigue con tu lápiz caras para unir al niño con su amiga

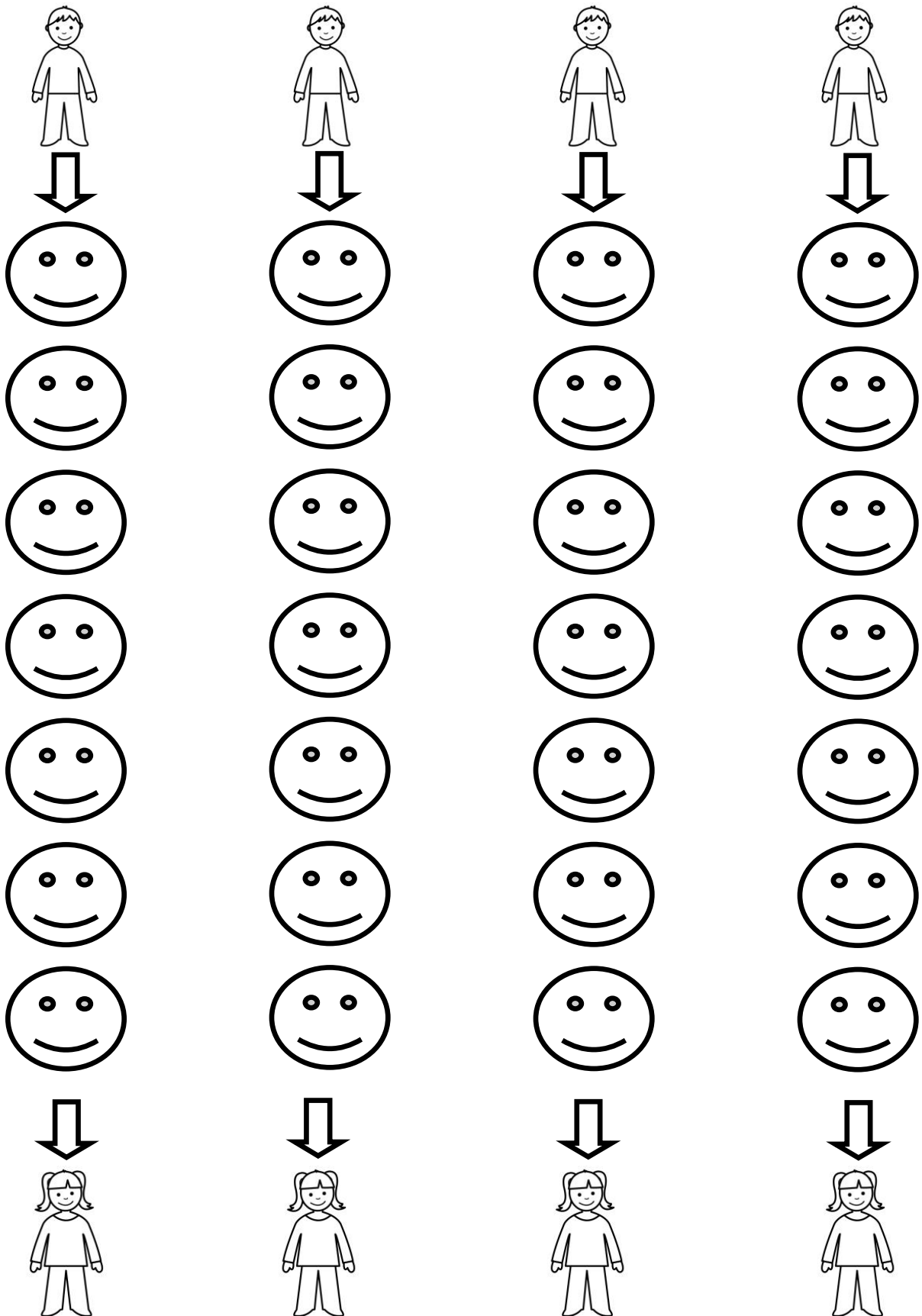

Actividades para mejorar motricidad fina

Sigue con tu lápiz caras para unir al niño con su amiga

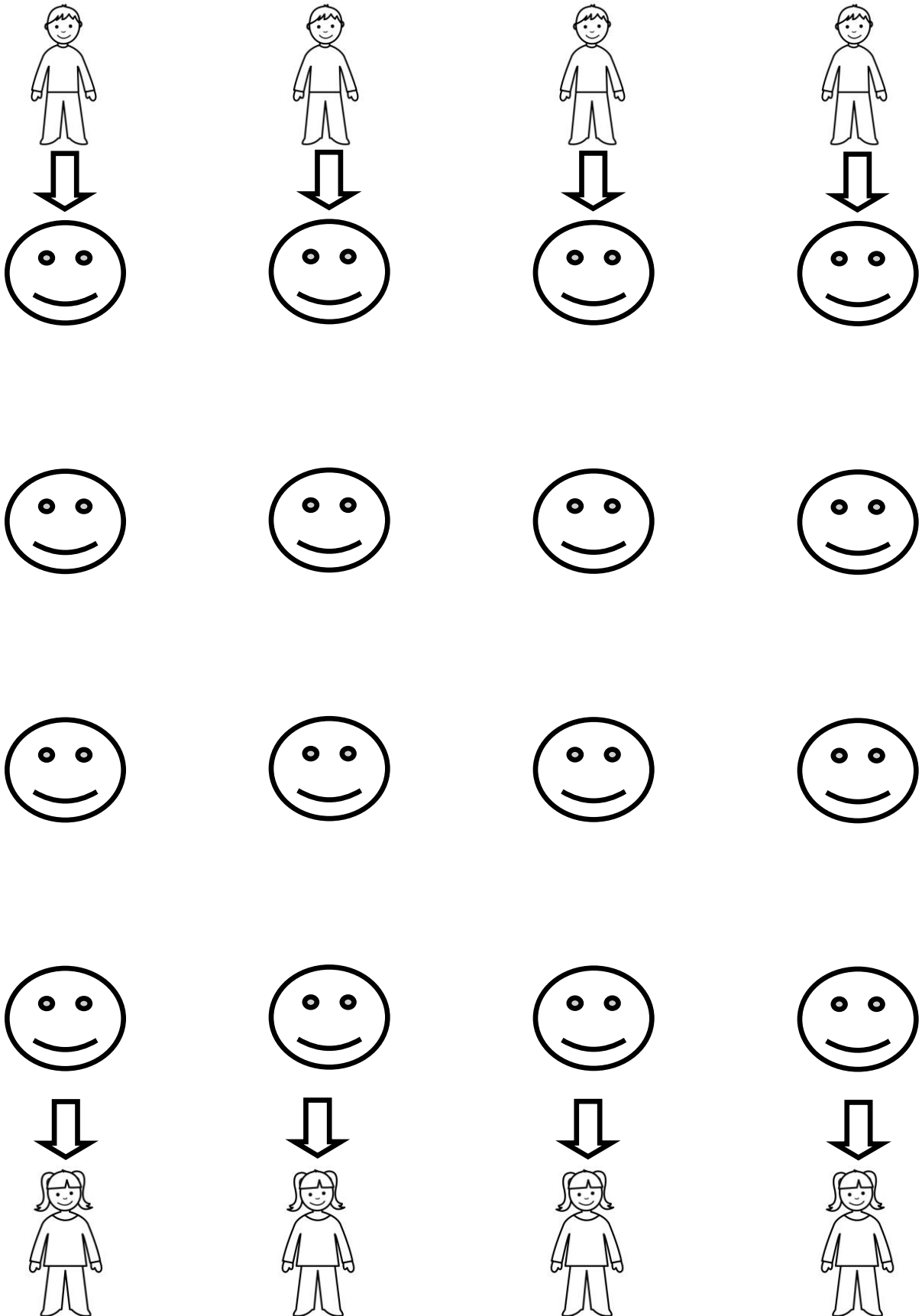

Actividades para mejorar motricidad fina

Sigue con tu lápiz los círculos para unir al niño con su balón

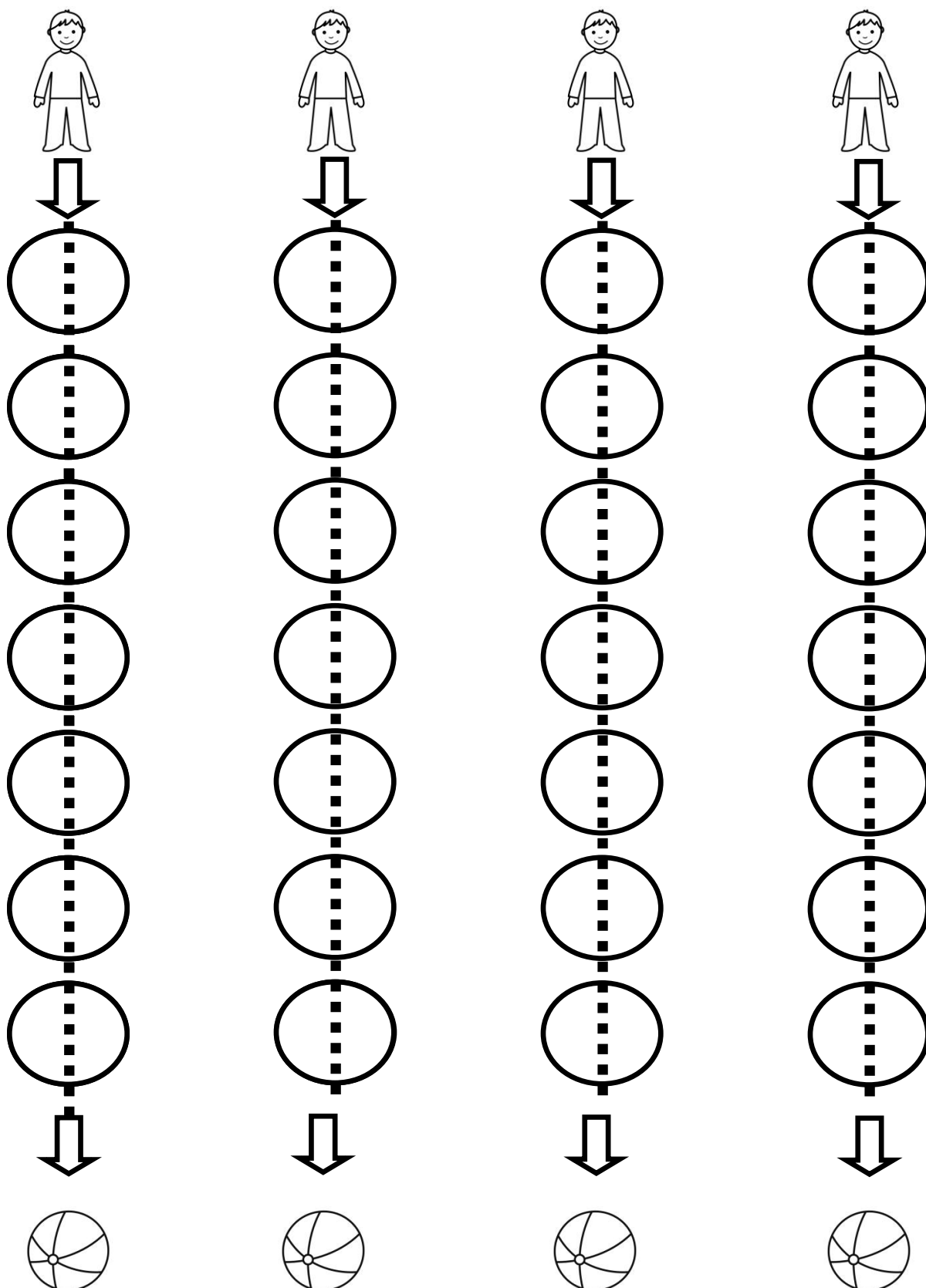

Actividades para mejorar motricidad fina

Sigue con tu lápiz los círculos para unir al niño con su balón

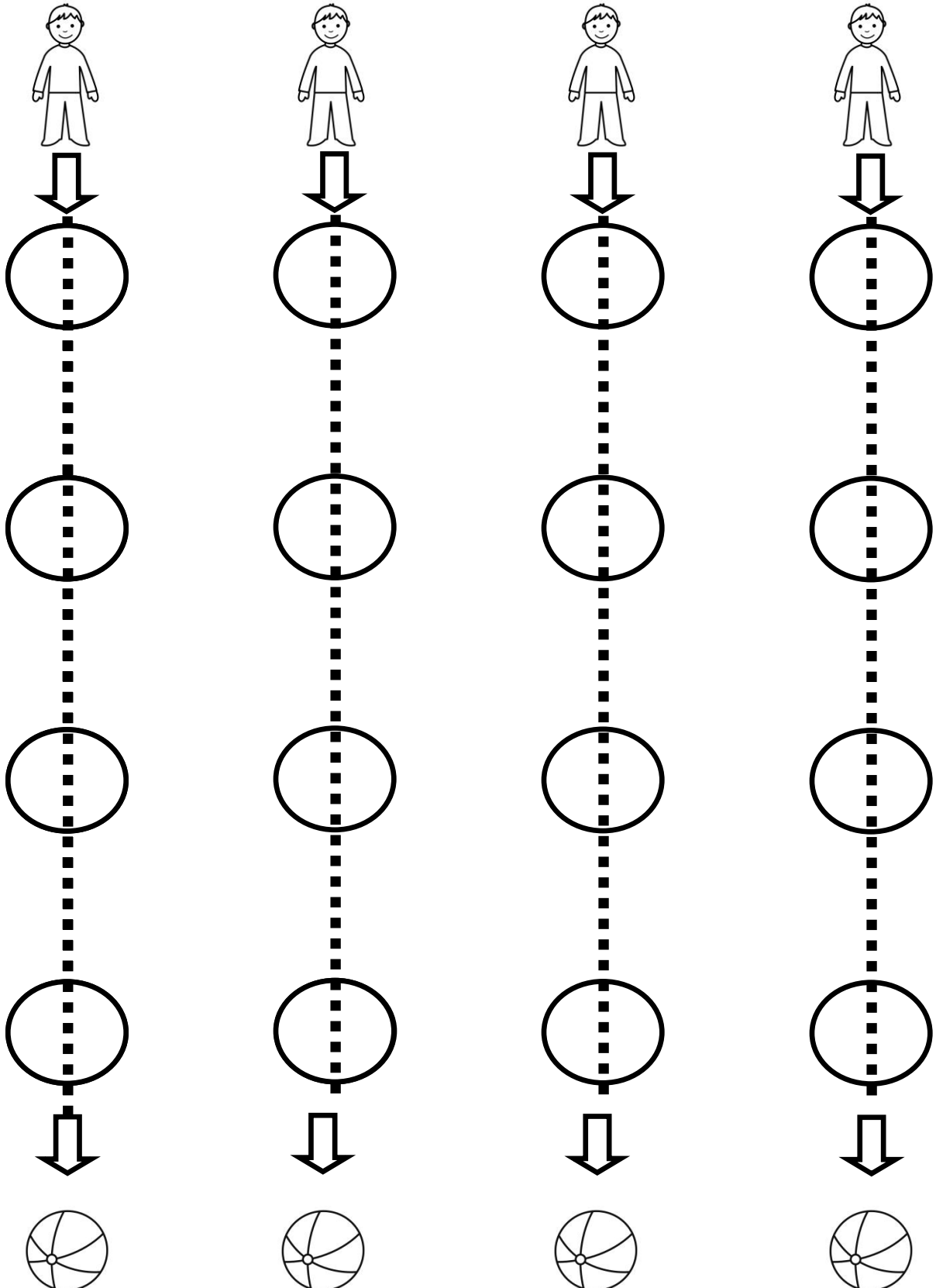

Actividades para mejorar motricidad fina

Sigue con tu lápiz los círculos para unir al niño con su balón

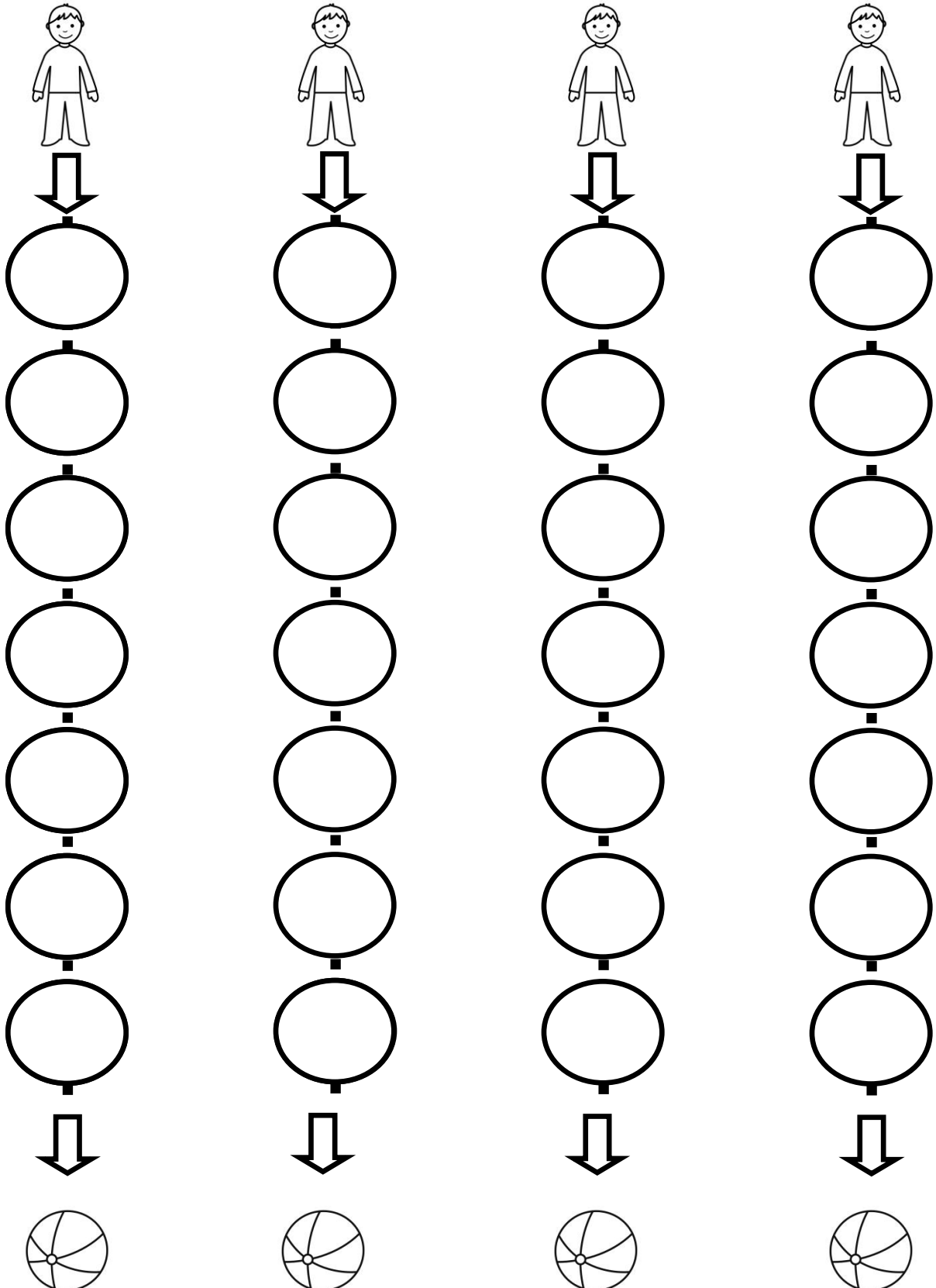

Actividades para mejorar motricidad fina

Sigue con tu lápiz los círculos para unir al niño con su balón

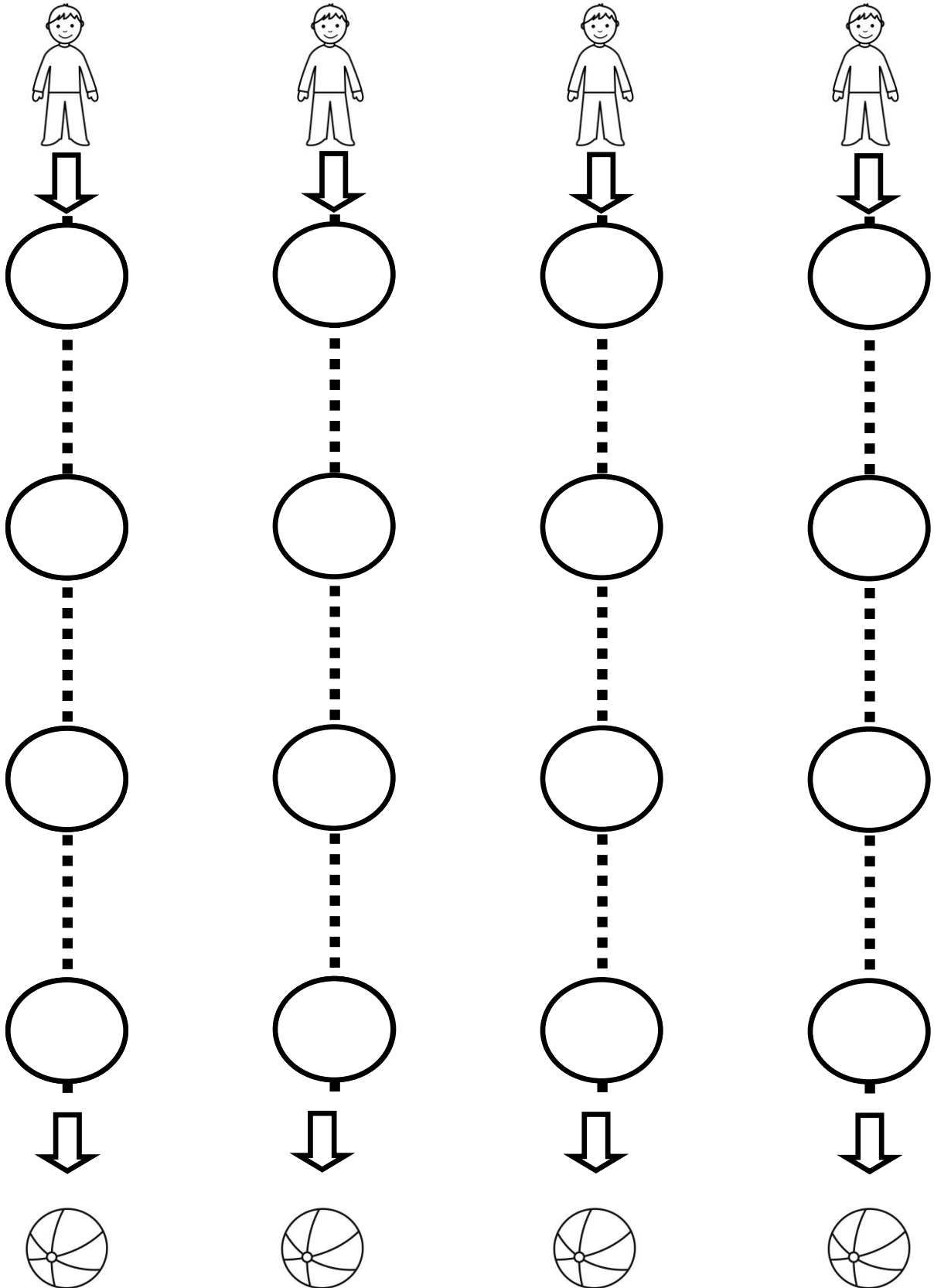

Actividades para mejorar motricidad fina

Sigue con tu lápiz los círculos para unir al niño con su balón

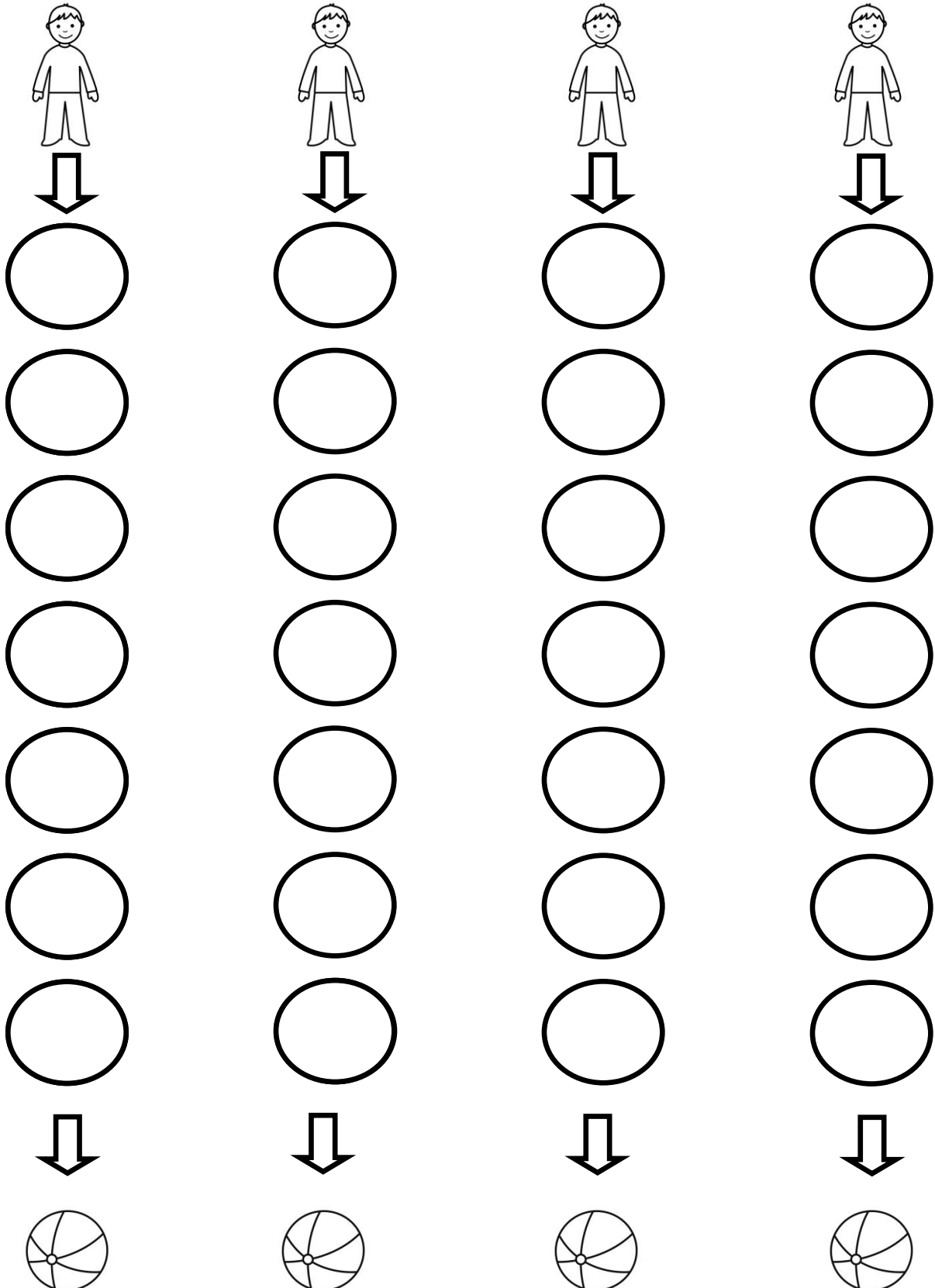

Actividades para mejorar motricidad fina

Sigue con tu lápiz los círculos para unir al niño con su balón

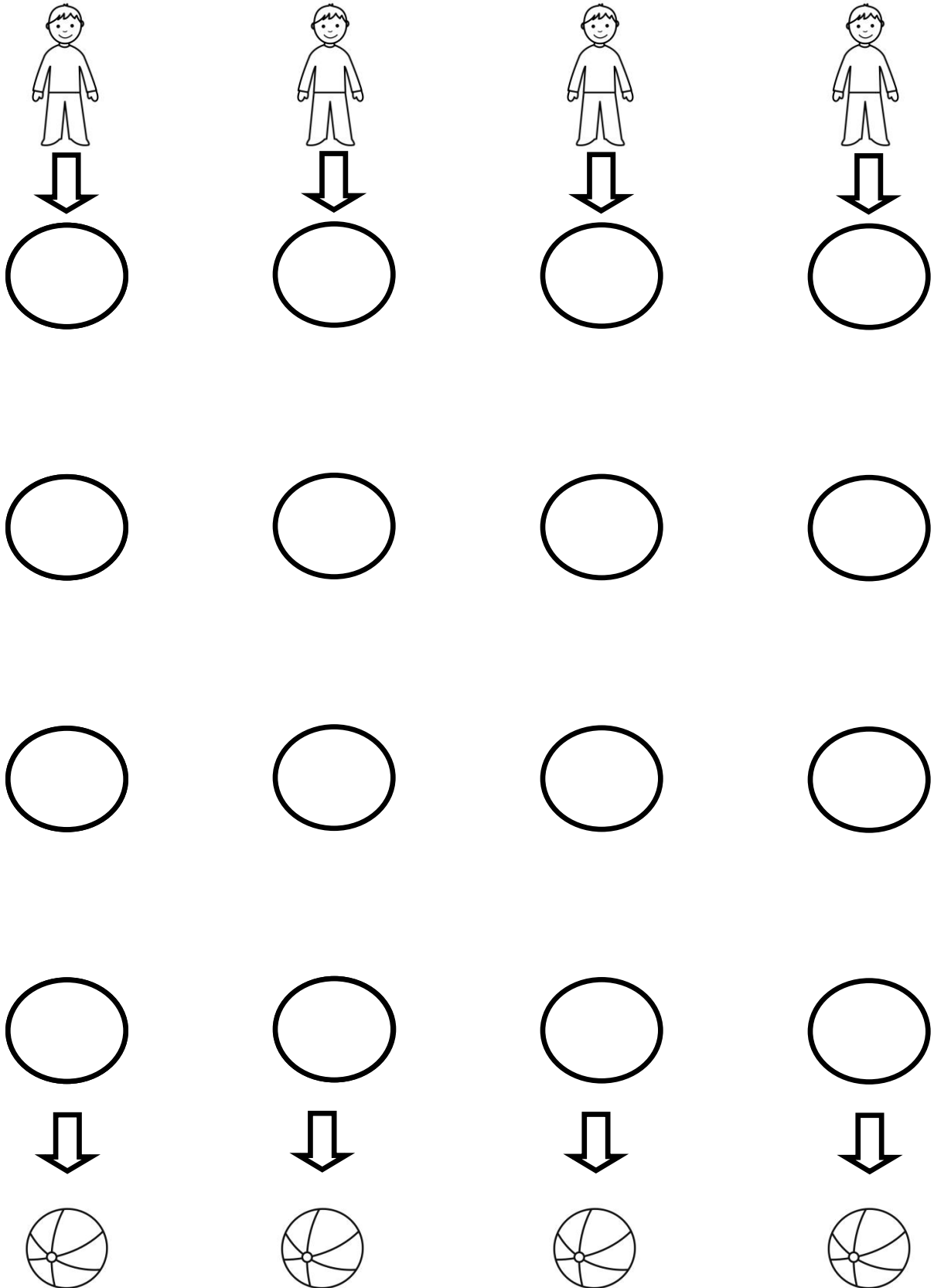

Actividades para mejorar motricidad fina

Sigue con tu lápiz los rayos para unir a nube y la tierra

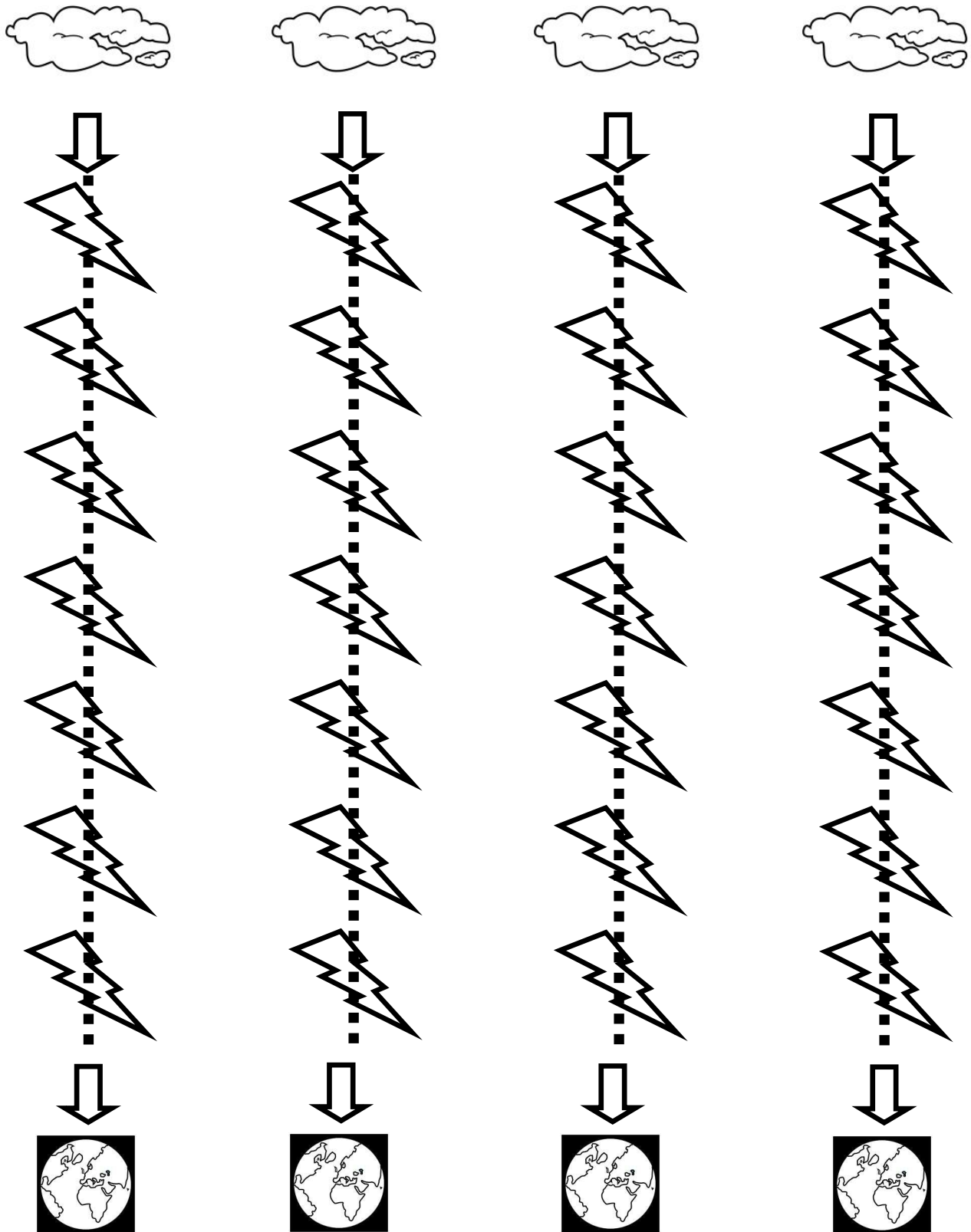

Actividades para mejorar motricidad fina

Sigue con tu lápiz los rayos para unir a nube y la tierra

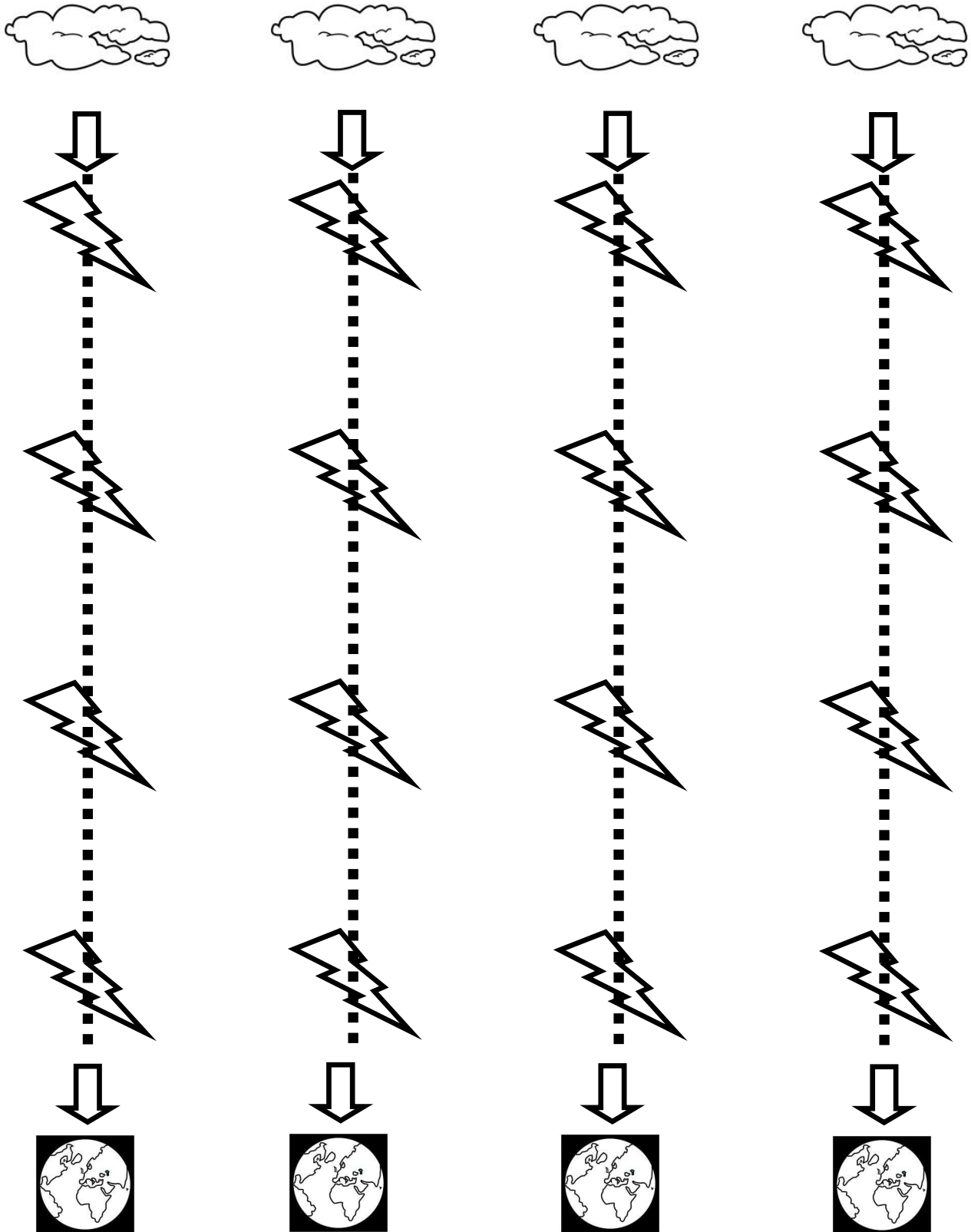

Actividades para mejorar motricidad fina

Sigue con tu lápiz los rayos para unir a nube y la tierra

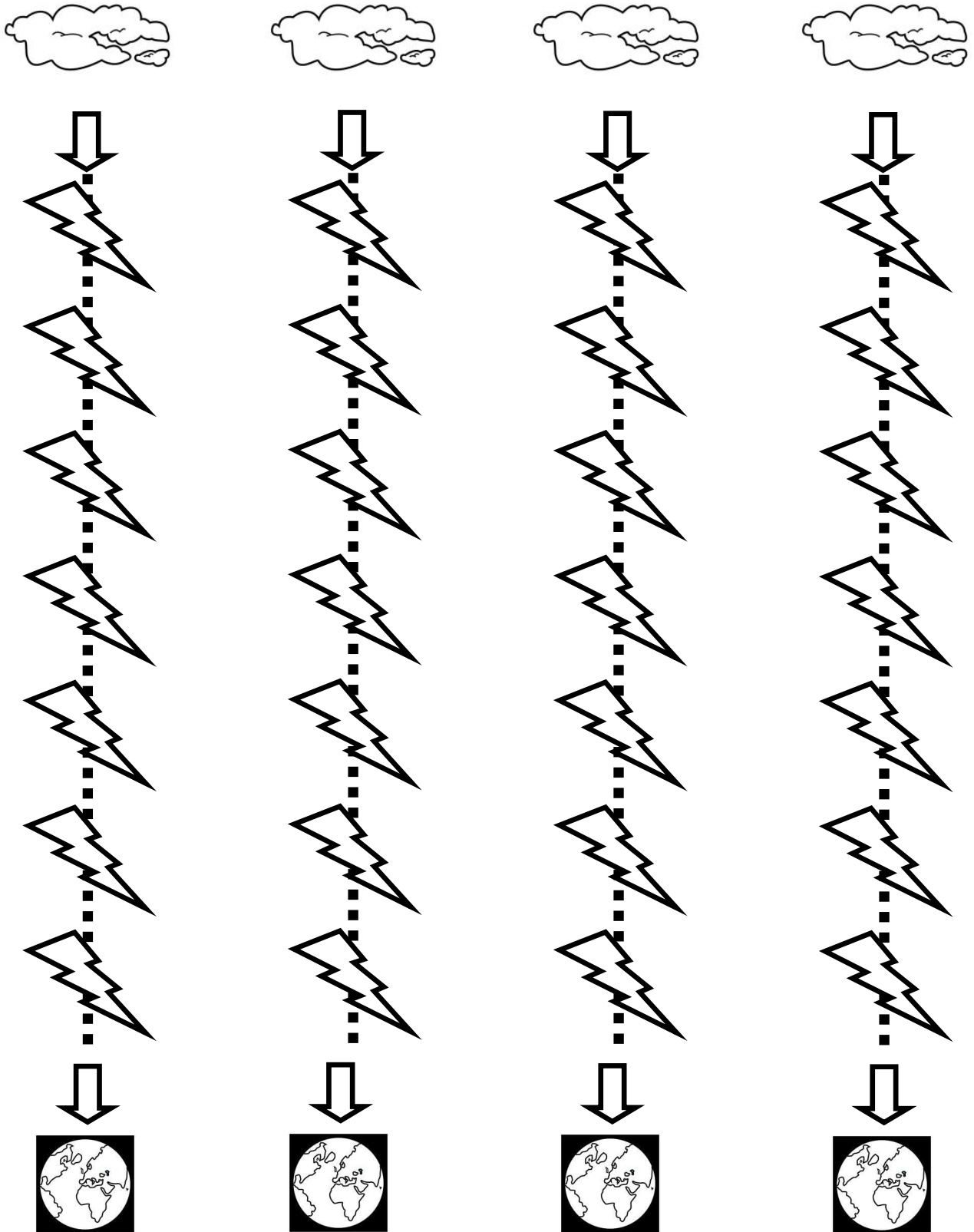

Actividades para mejorar motricidad fina

Sigue con tu lápiz los rayos para unir a nube y la tierra

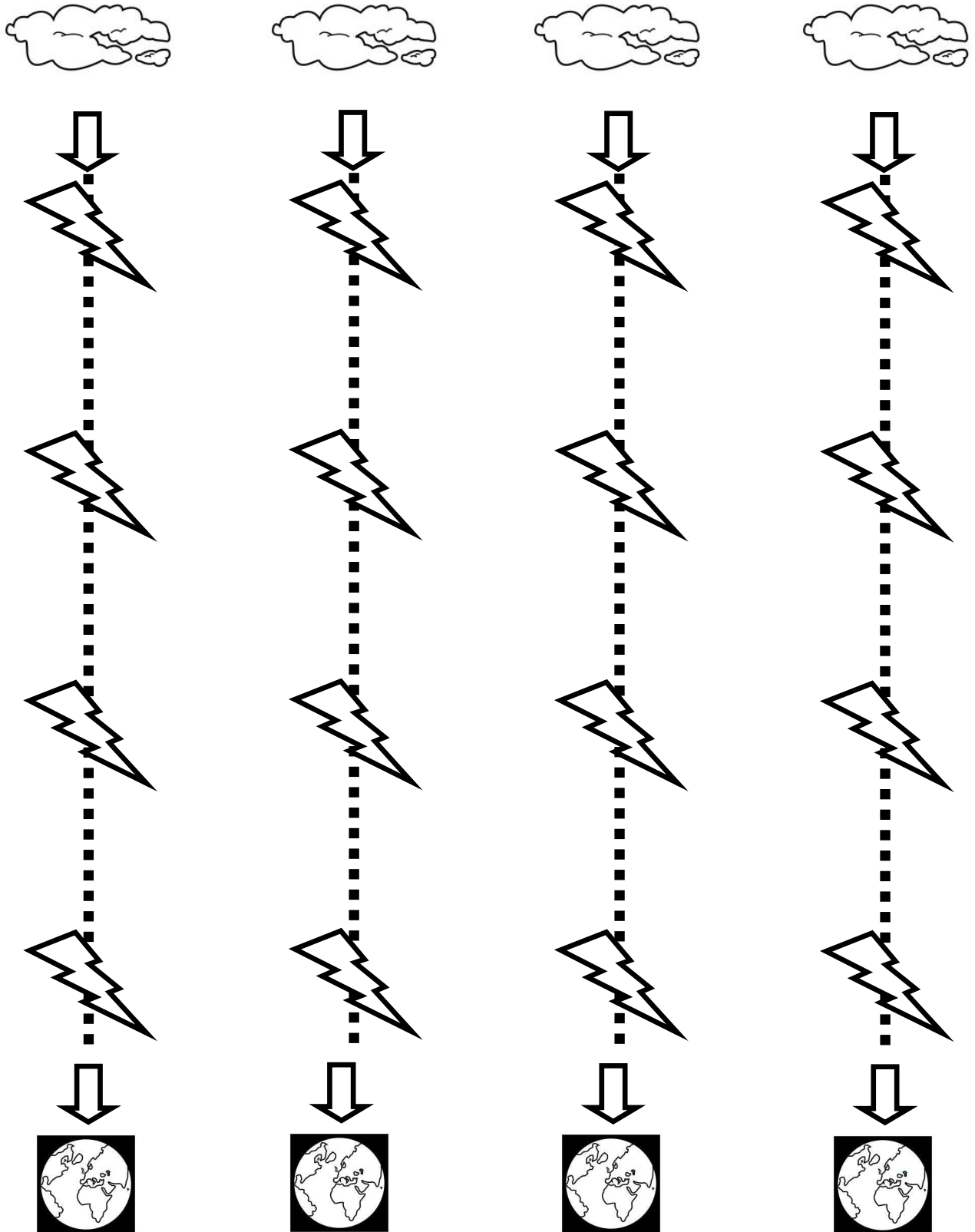

Actividades para mejorar motricidad fina

Sigue con tu lápiz los rayos para unir a nube y la tierra

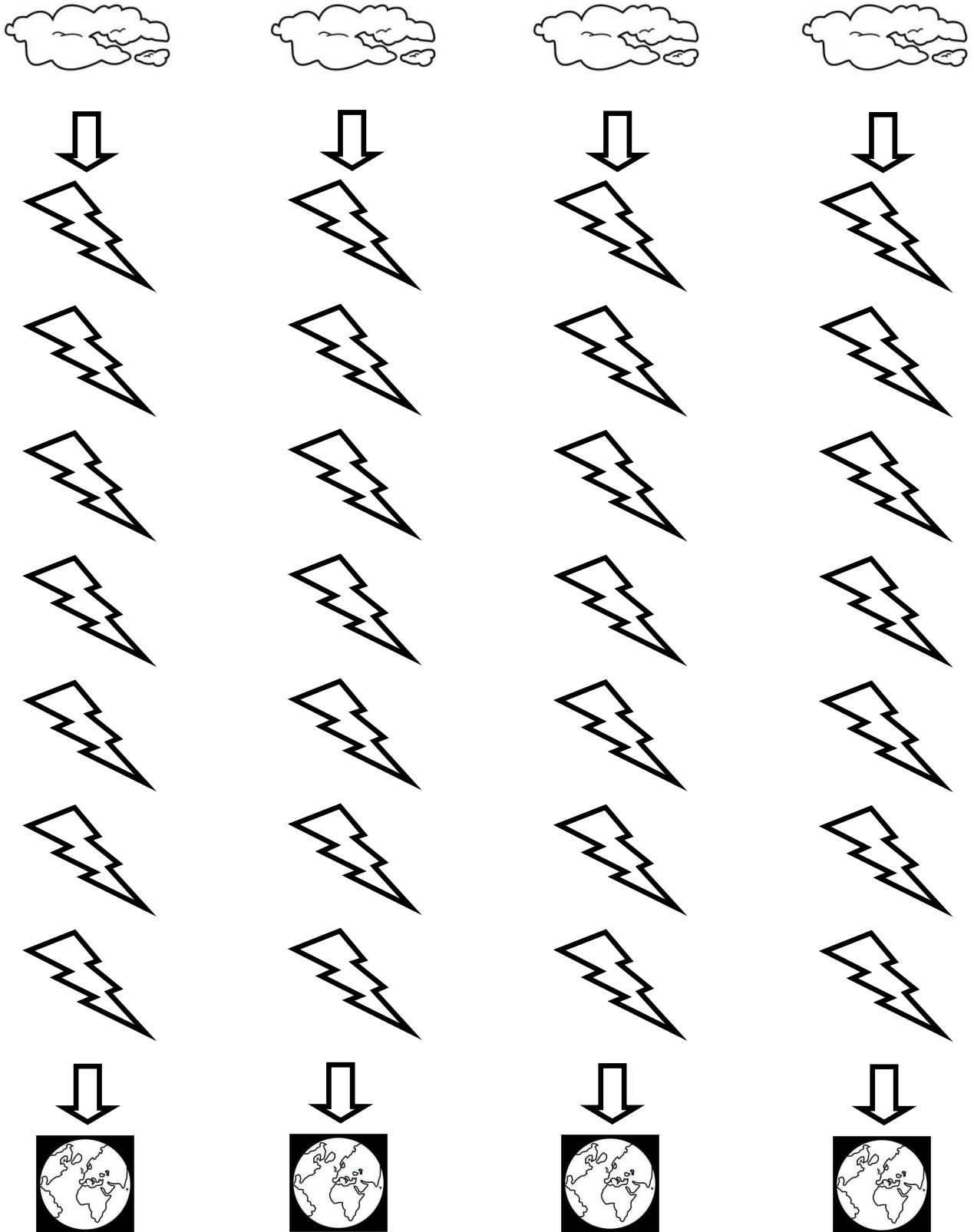

Actividades para mejorar motricidad fina

Sigue con tu lápiz los rayos para unir a nube y la tierra

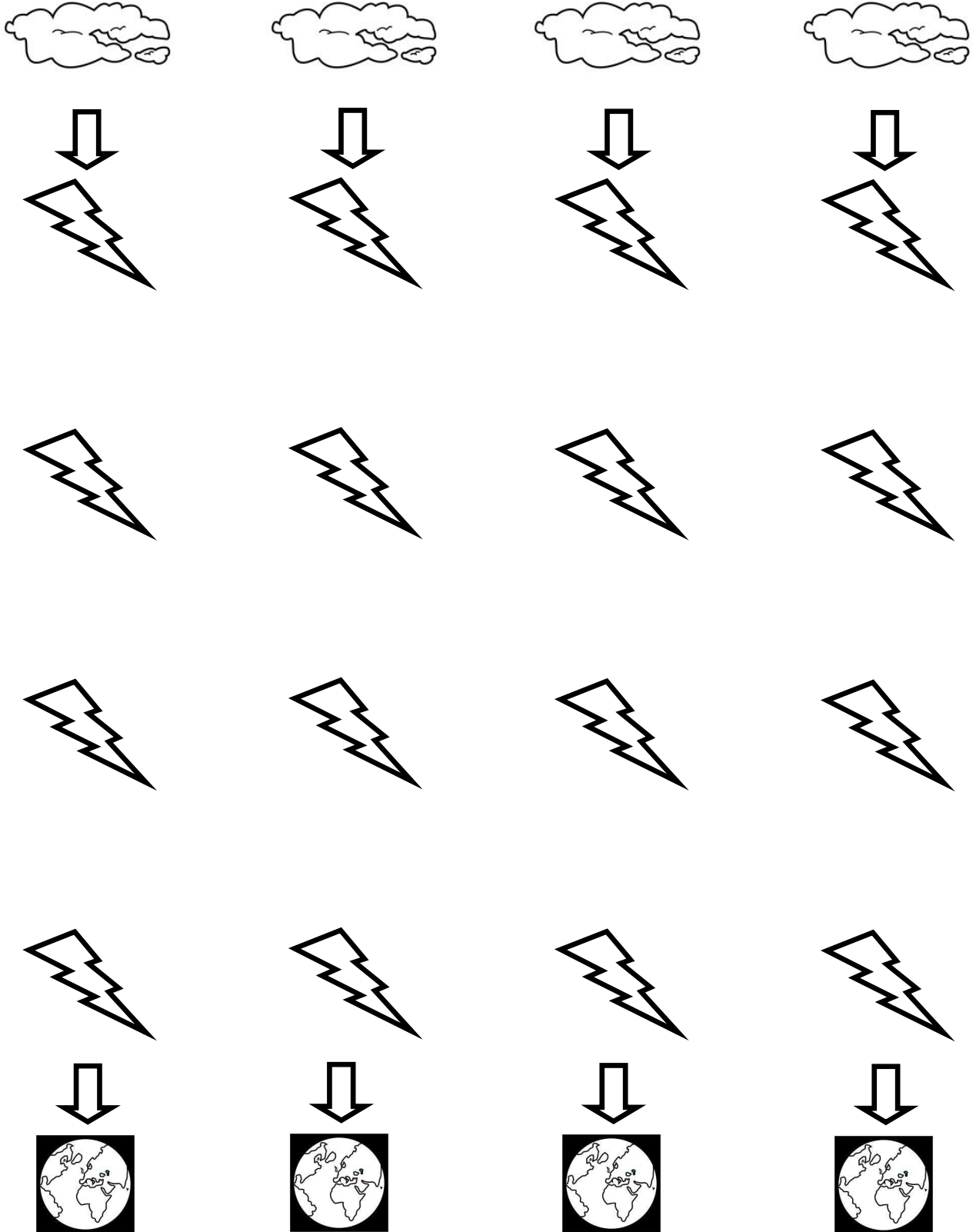

Actividades para mejorar motricidad fina

Sigue con tu lápiz las estrellitas para ir desde el sol a la tierra



Actividades para mejorar motricidad fina

Sigue con tu lápiz las estrellitas para ir desde el sol a la tierra



Actividades para mejorar motricidad fina

Sigue con tu lápiz las estrellitas para ir desde el sol a la tierra



Actividades para mejorar motricidad fina

Sigue con tu lápiz las estrellitas para ir desde el sol a la tierra

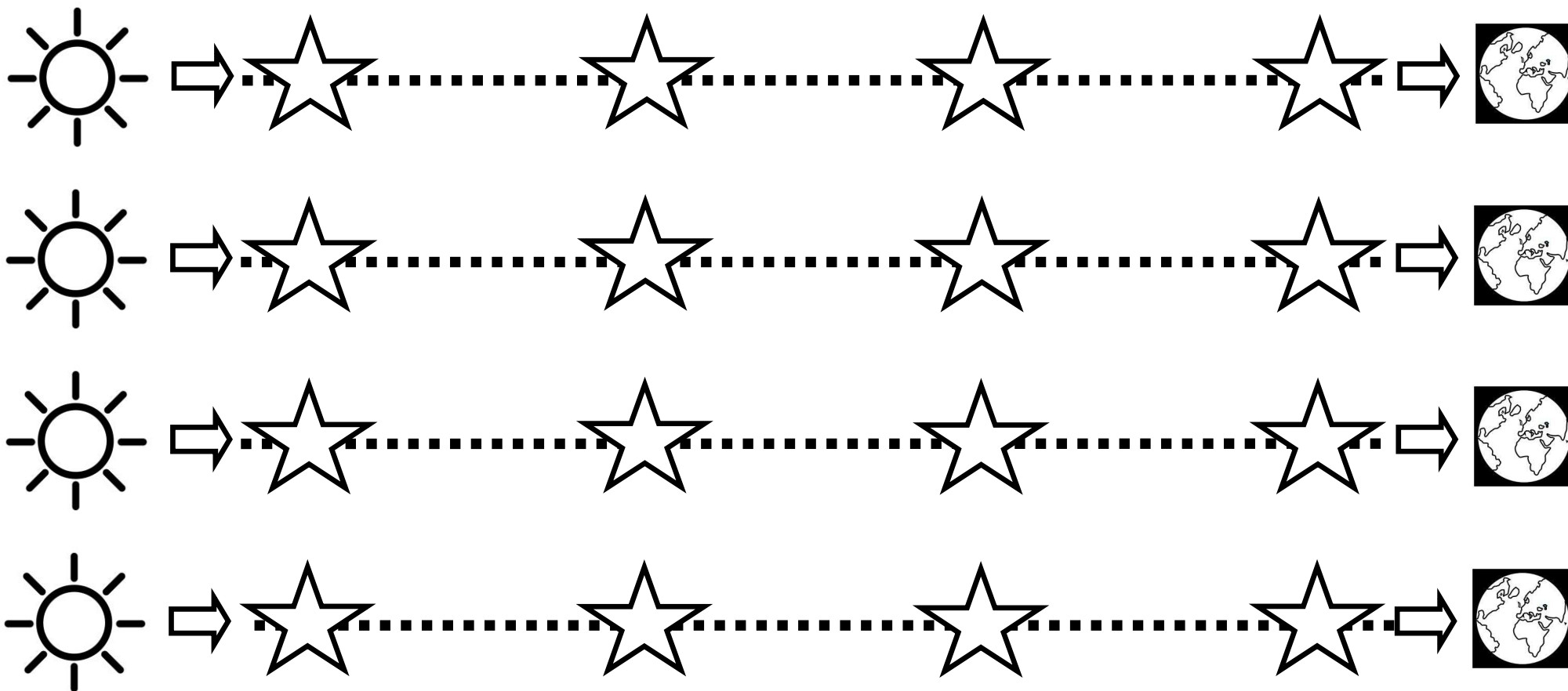

Actividades para mejorar motricidad fina

Sigue con tu lápiz las estrellitas para ir desde el sol a la tierra



Actividades para mejorar motricidad fina

Sigue con tu lápiz las estrellitas para ir desde el sol a la tierra

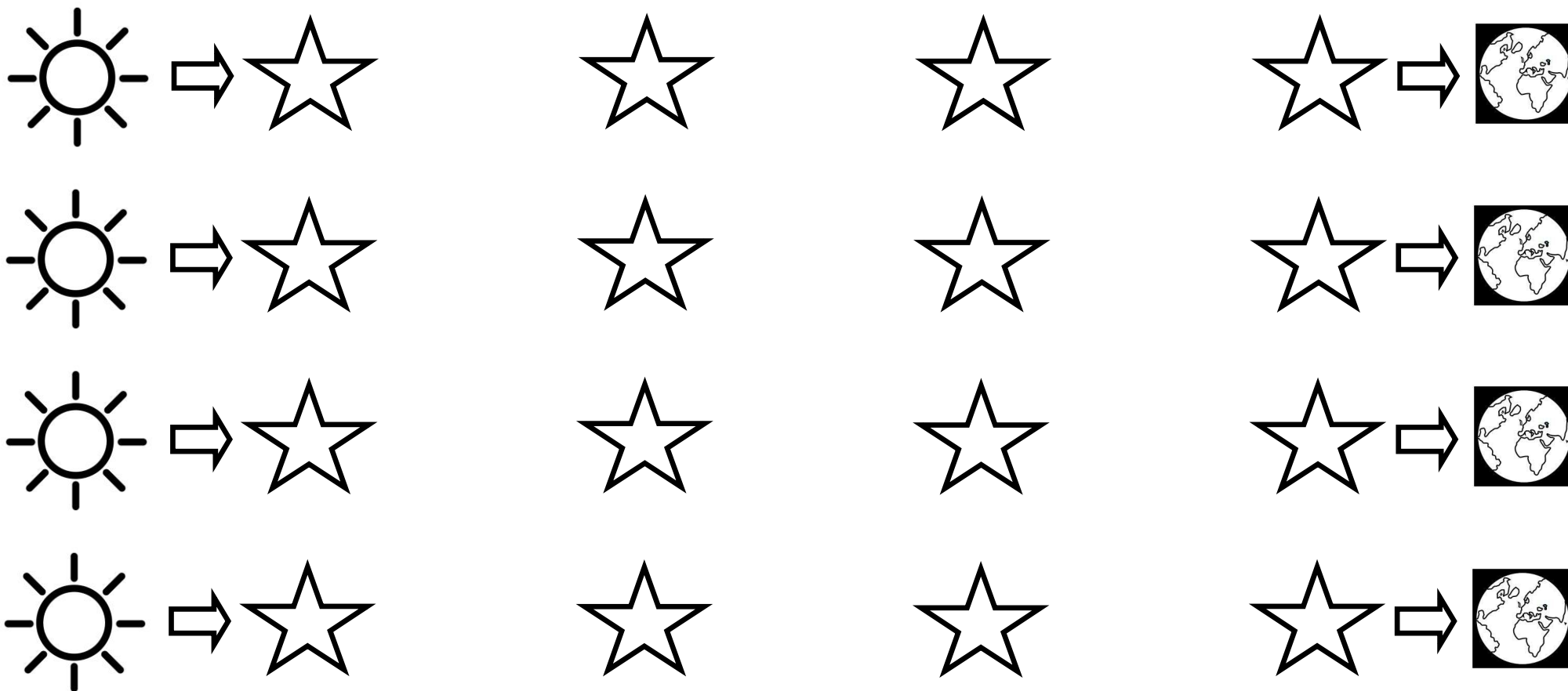

Actividades para mejorar motricidad fina

Sigue con tu lápiz los corazones para unir a la mama y a su bebe

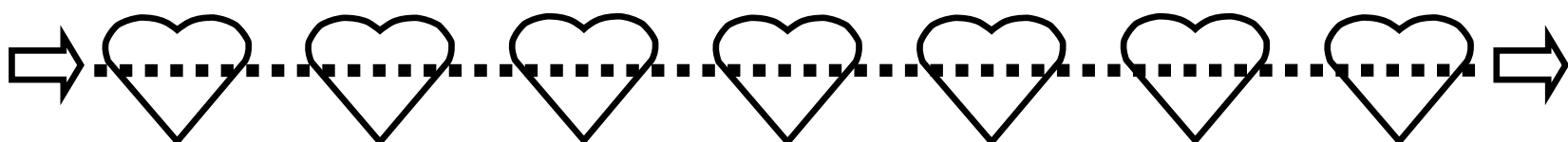
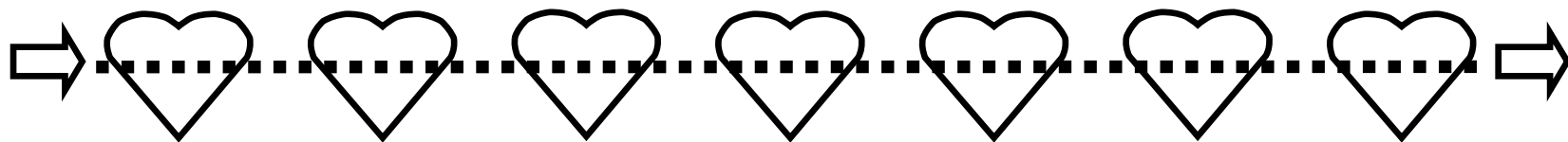

Actividades para mejorar motricidad fina

Sigue con tu lápiz los corazones para unir a la mama y a su bebe

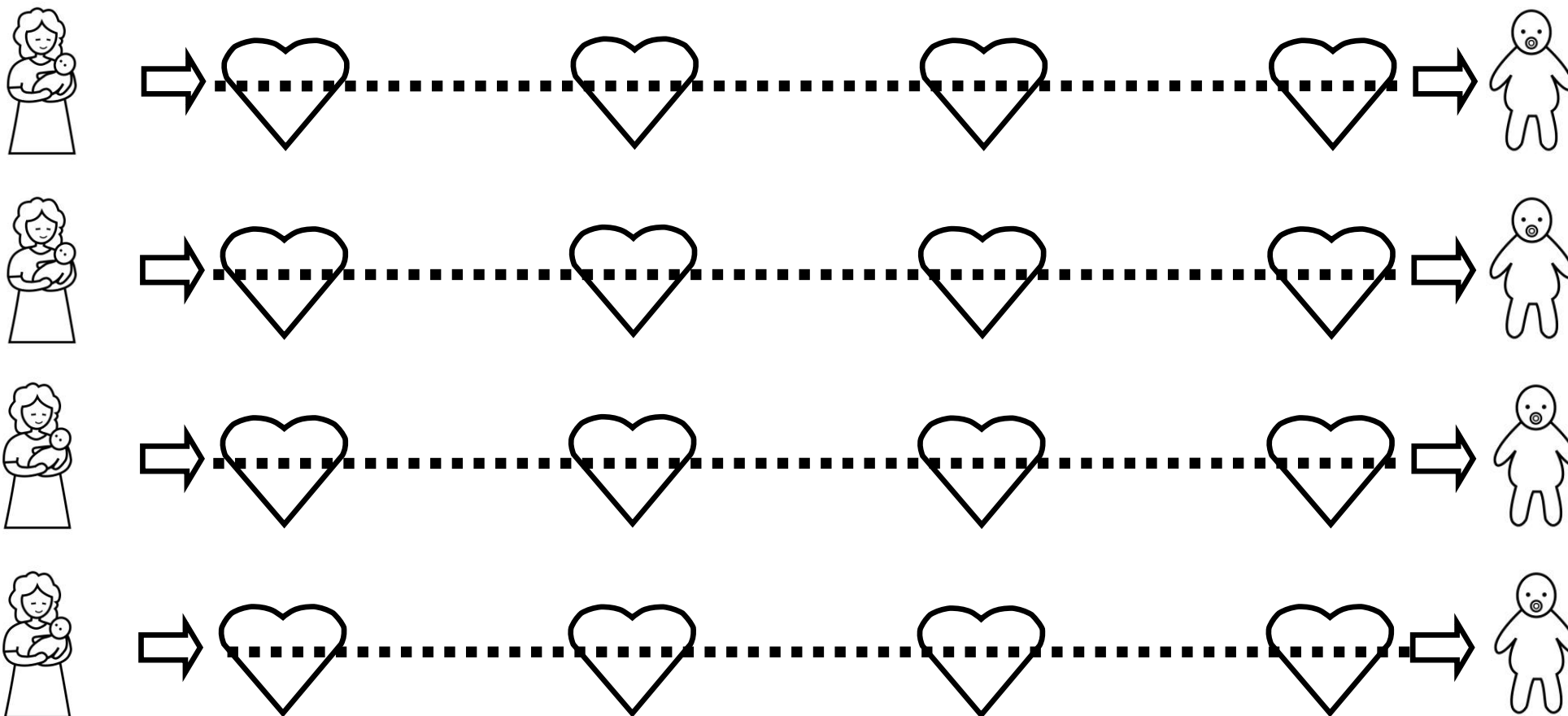

Actividades para mejorar motricidad fina

Sigue con tu lápiz los corazones para unir a la mama y a su bebe

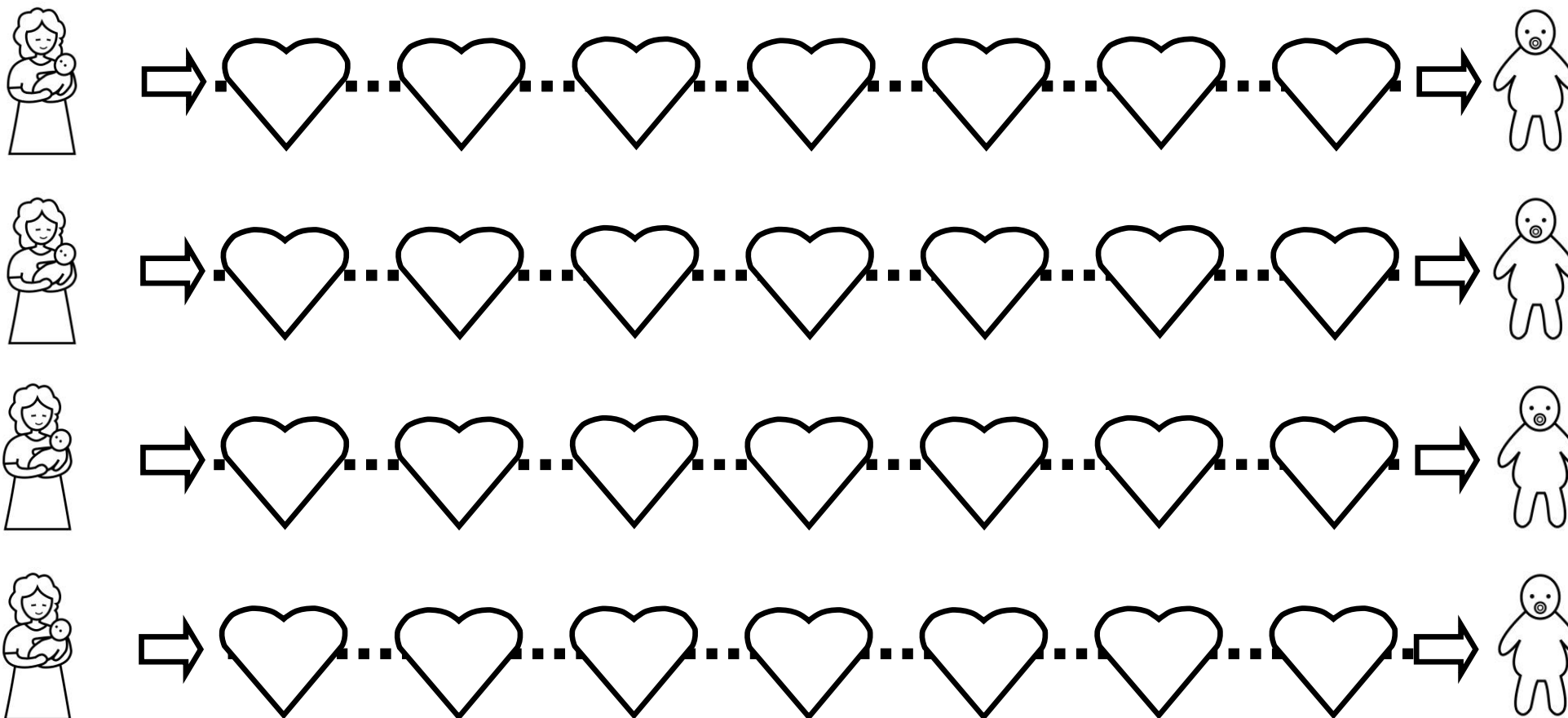

Actividades para mejorar motricidad fina

Sigue con tu lápiz los corazones para unir a la mama y a su bebe

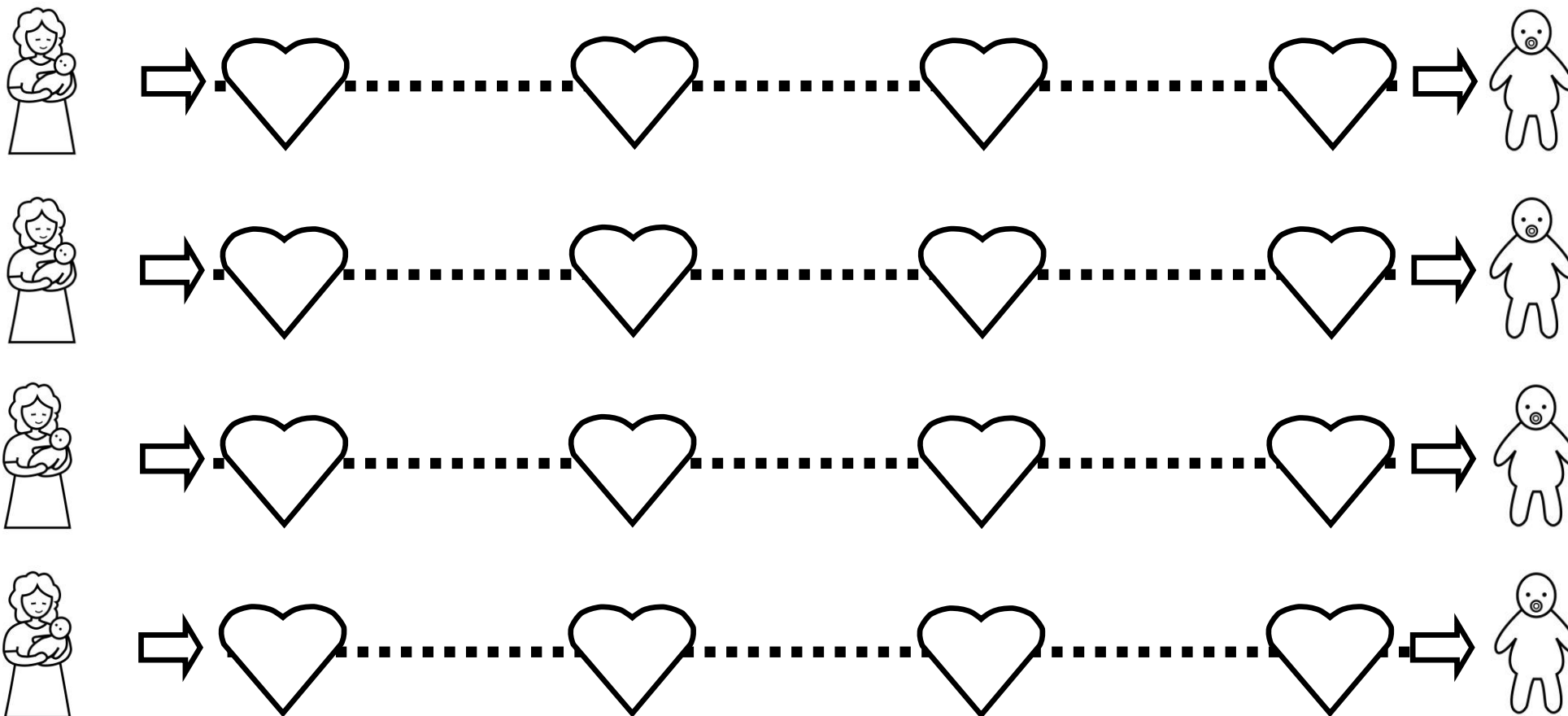

Actividades para mejorar motricidad fina

Sigue con tu lápiz los corazones para unir a la mama y a su bebe

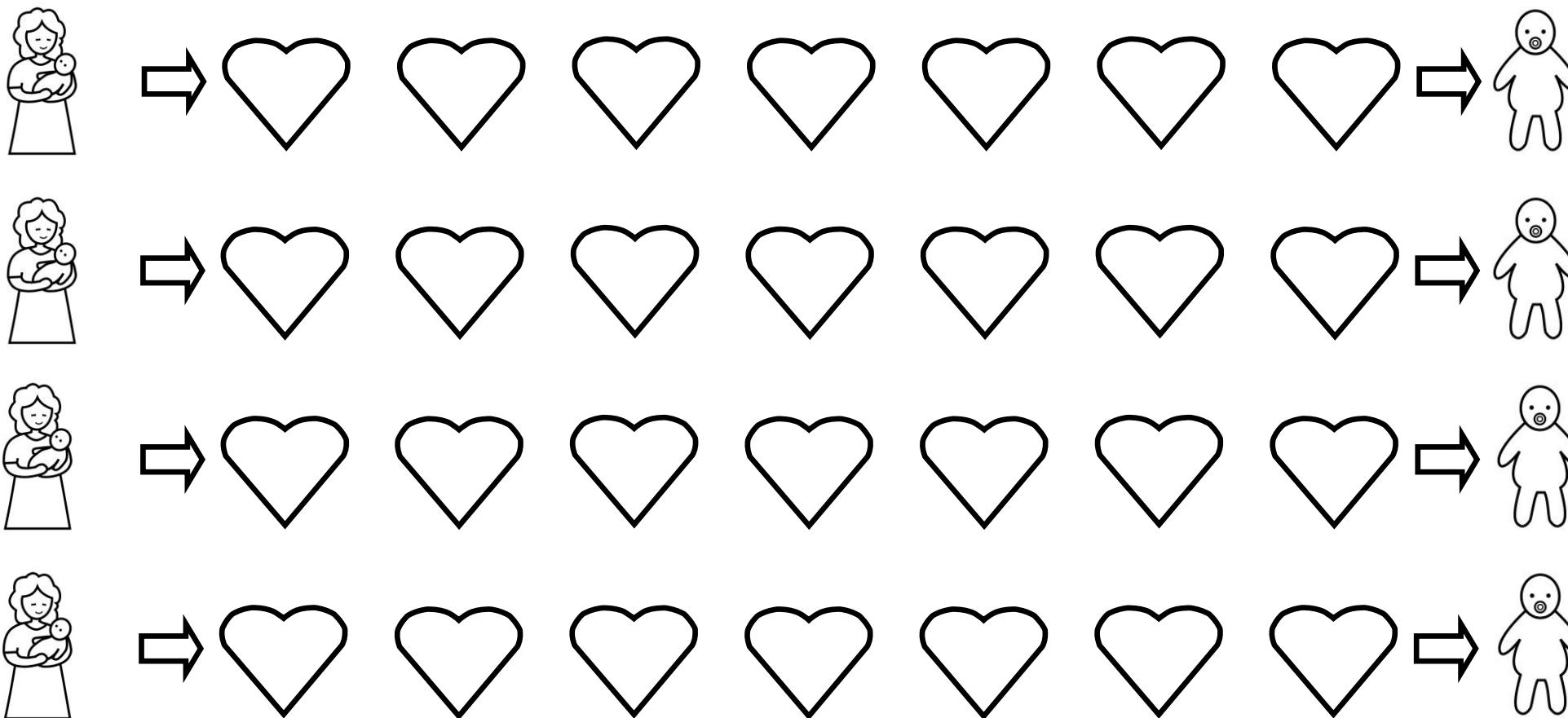

Actividades para mejorar motricidad fina

Sigue con tu lápiz los corazones para unir a la mama y a su bebe

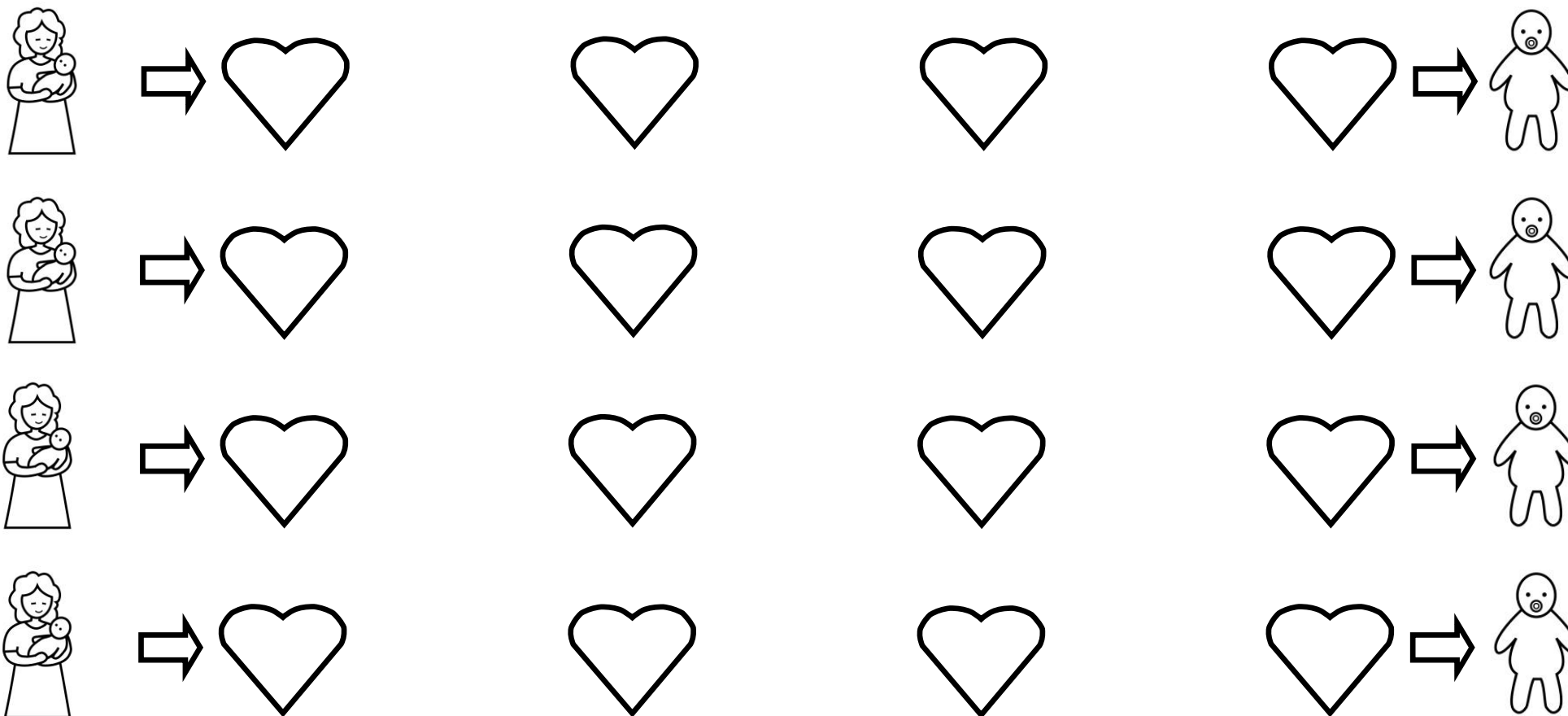

Actividades para mejorar motricidad fina

Sigue con tu lápiz las caras para unir al niño con su amiga

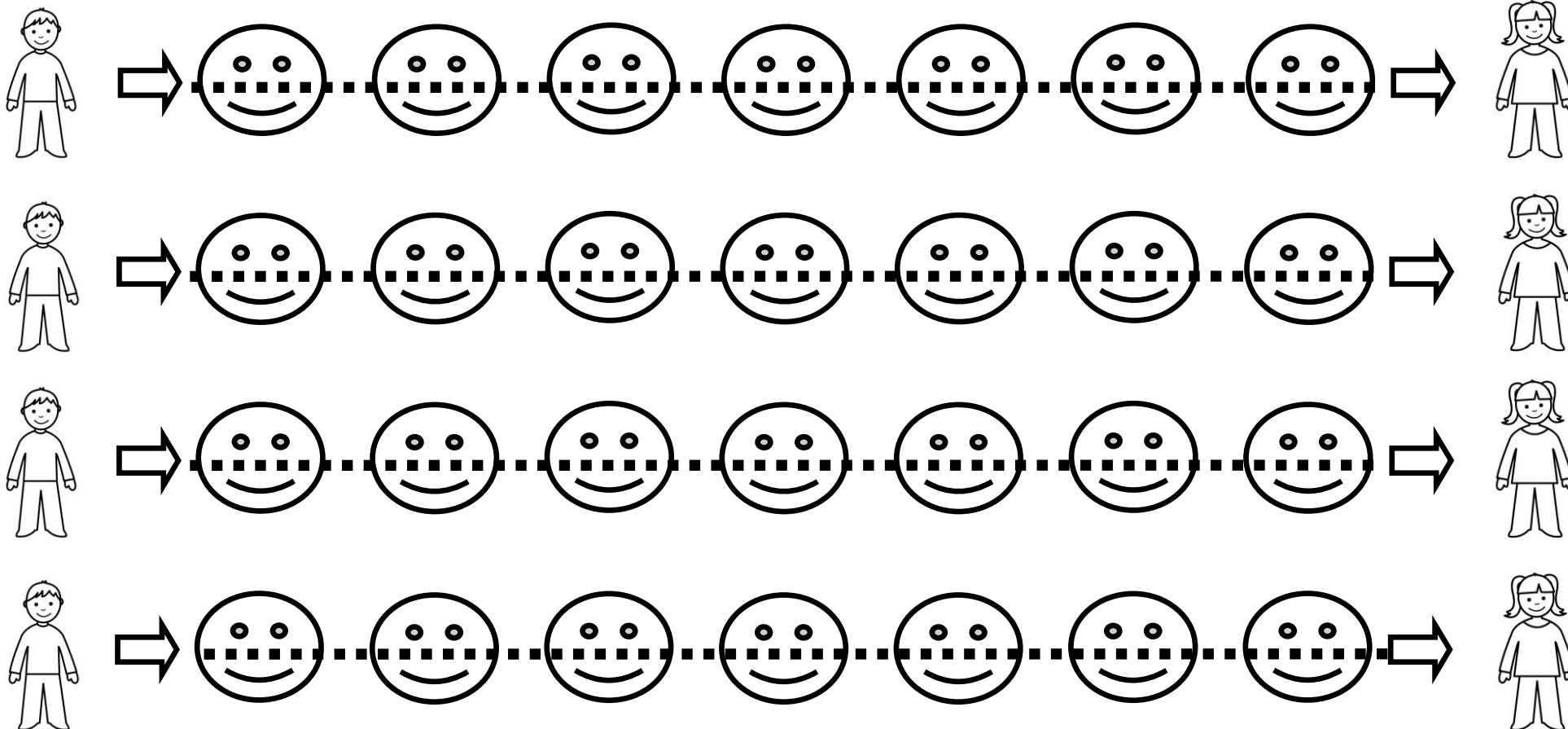

Actividades para mejorar motricidad fina

Sigue con tu lápiz las caras para unir al niño con su amiga

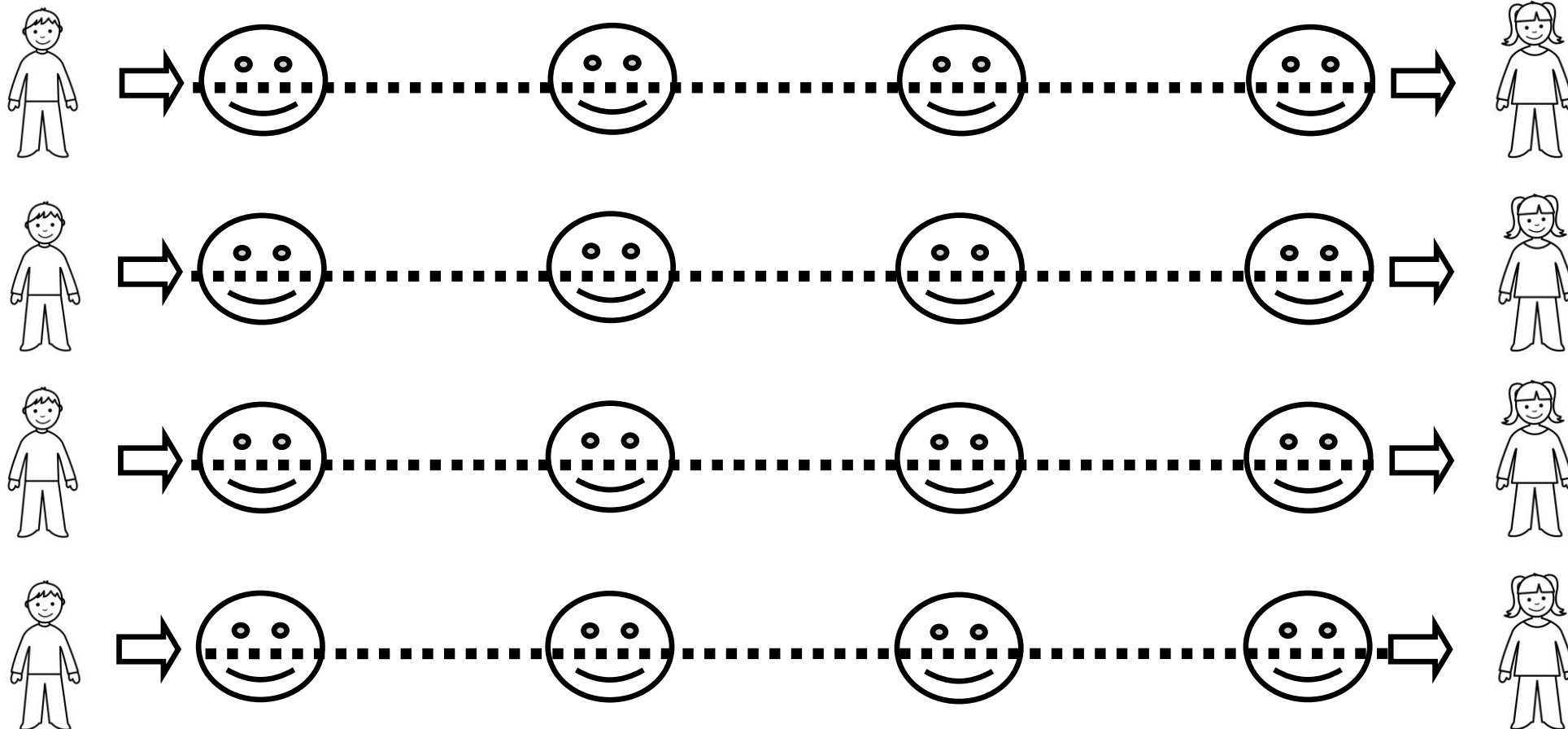

Actividades para mejorar motricidad fina

Sigue con tu lápiz las caras para unir al niño con su amiga

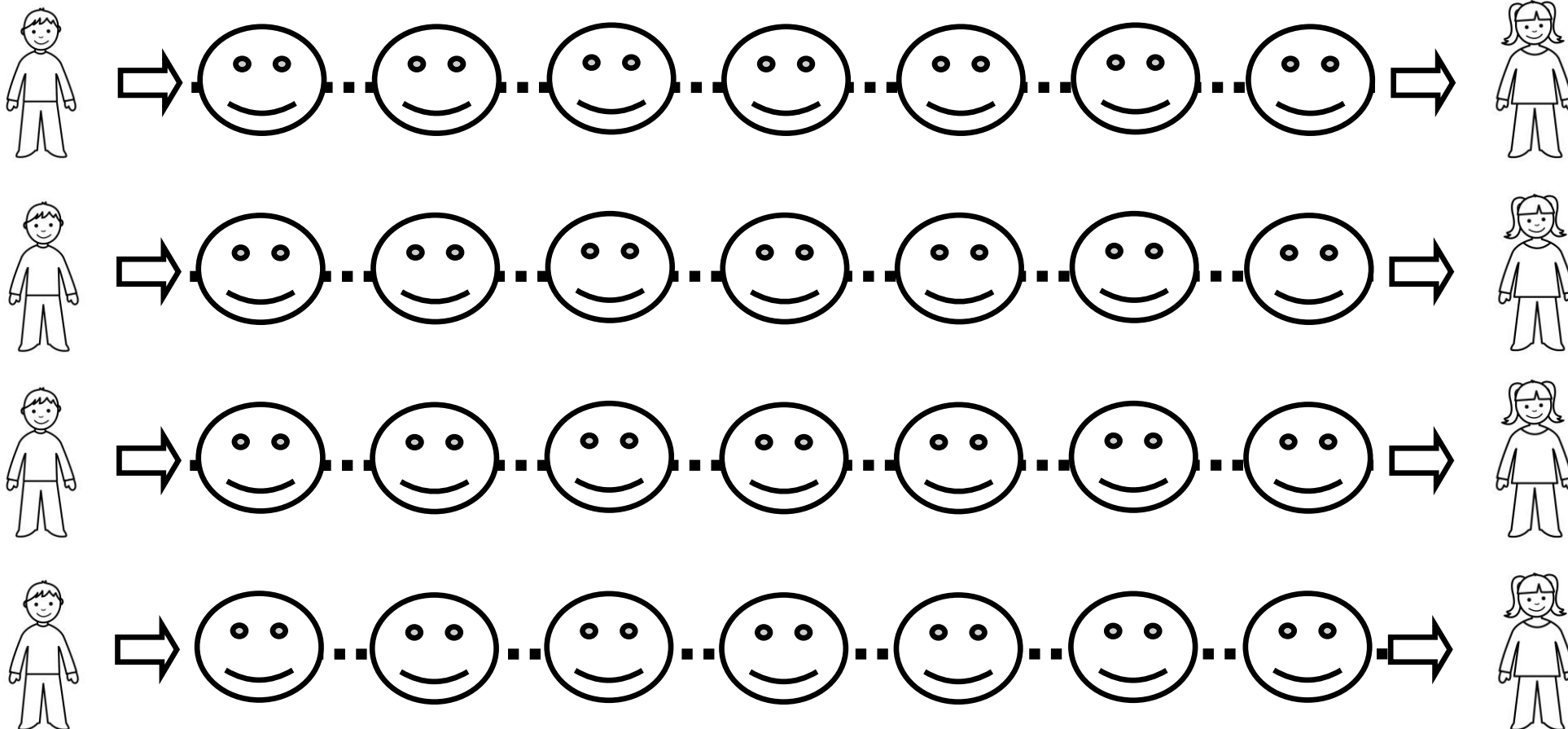

Actividades para mejorar motricidad fina

Sigue con tu lápiz las caras para unir al niño con su amiga

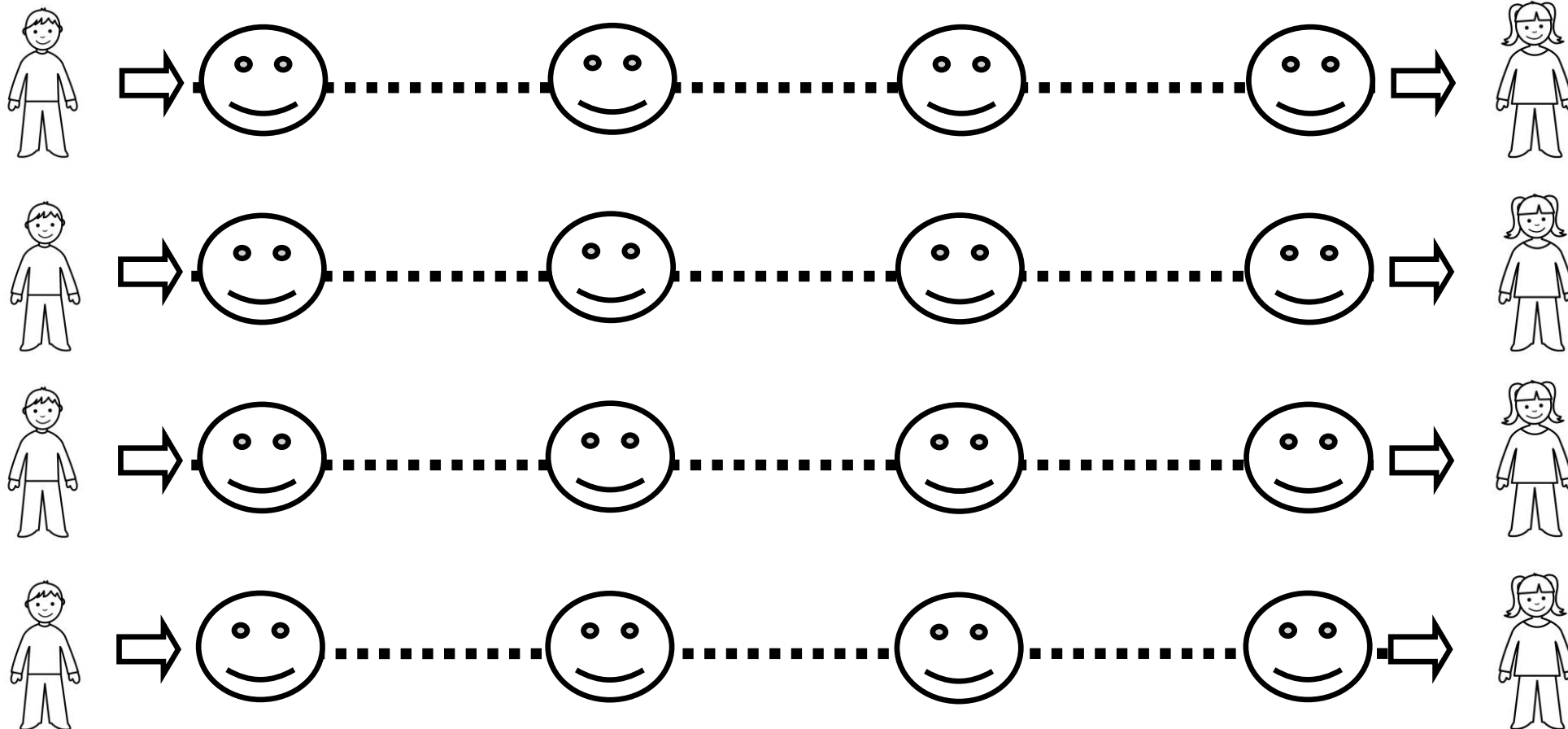

Actividades para mejorar motricidad fina

Sigue con tu lápiz las caras para unir al niño con su amiga

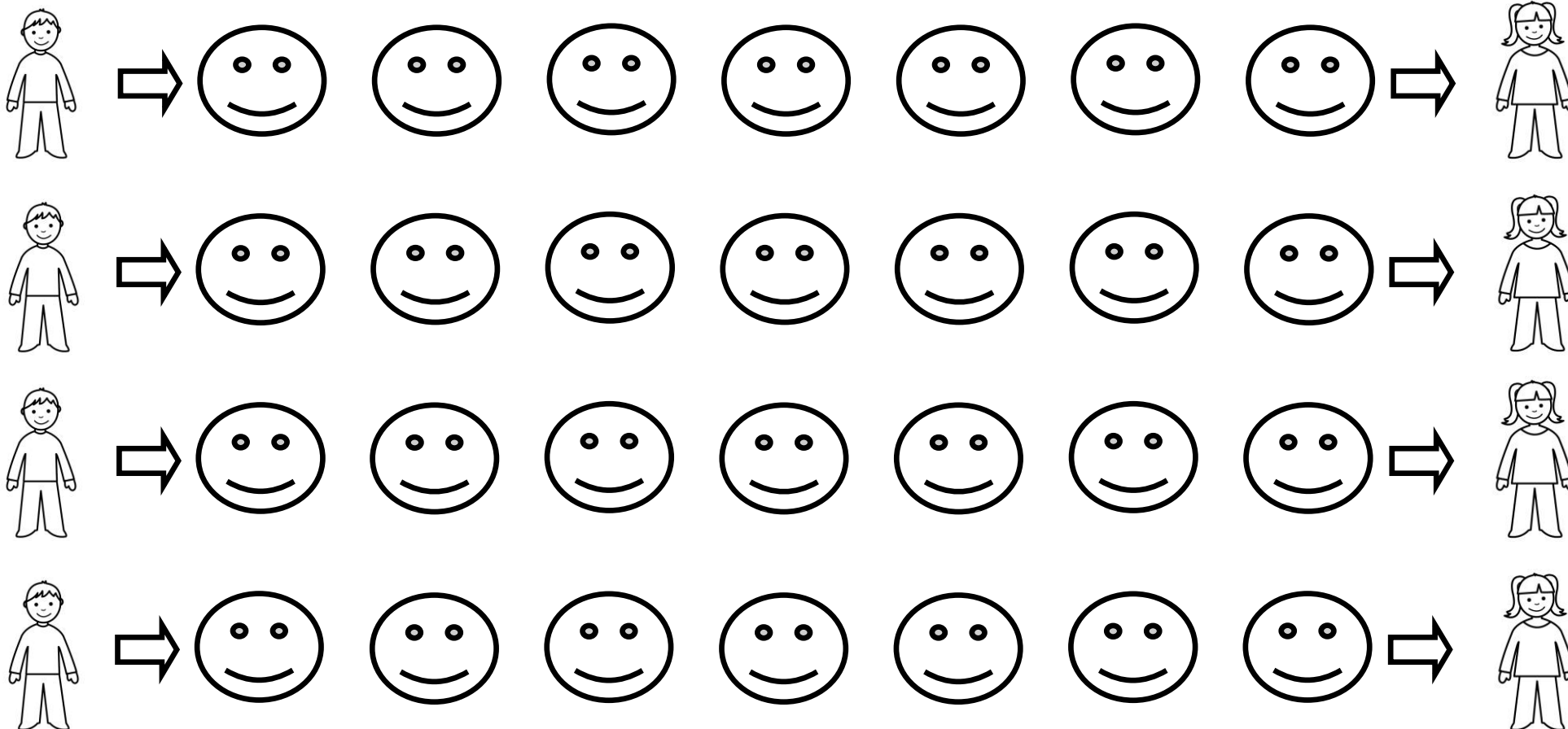

Actividades para mejorar motricidad fina

Sigue con tu lápiz las caras para unir al niño con su amiga

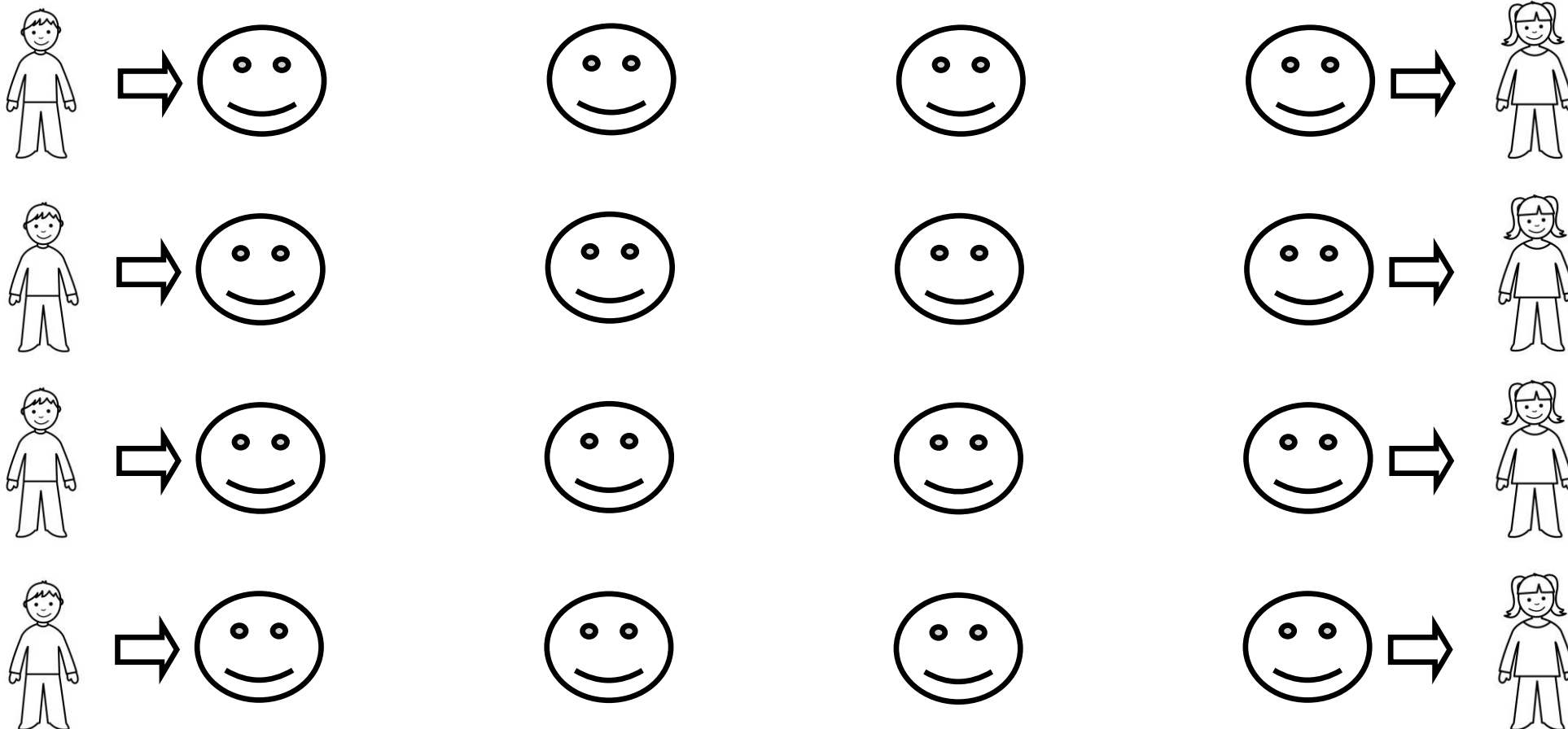

Actividades para mejorar motricidad fina

Sigue con tu lápiz los círculos para unir al niño con su balón

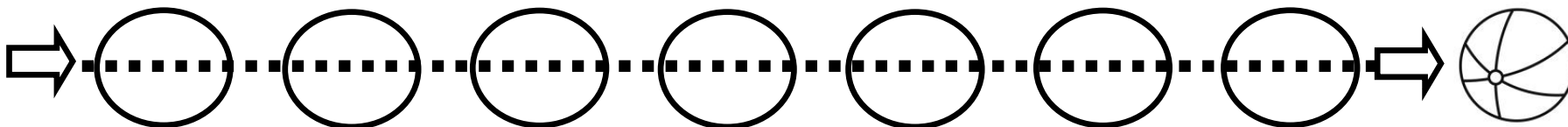
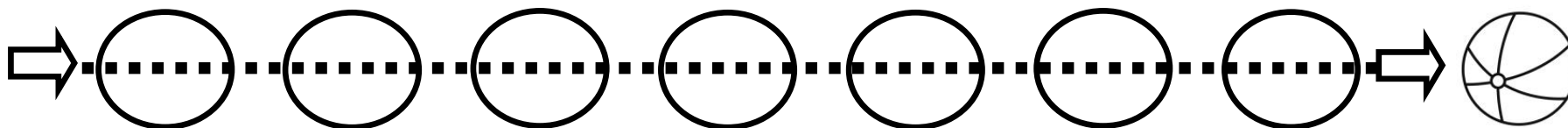
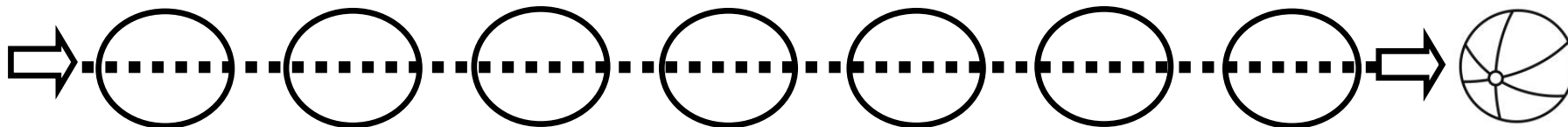
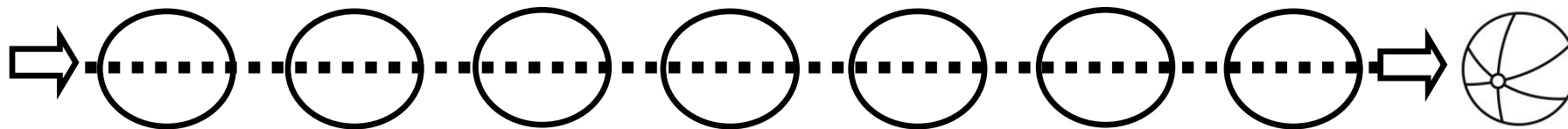

Actividades para mejorar motricidad fina

Sigue con tu lápiz los círculos para unir al niño con su balón

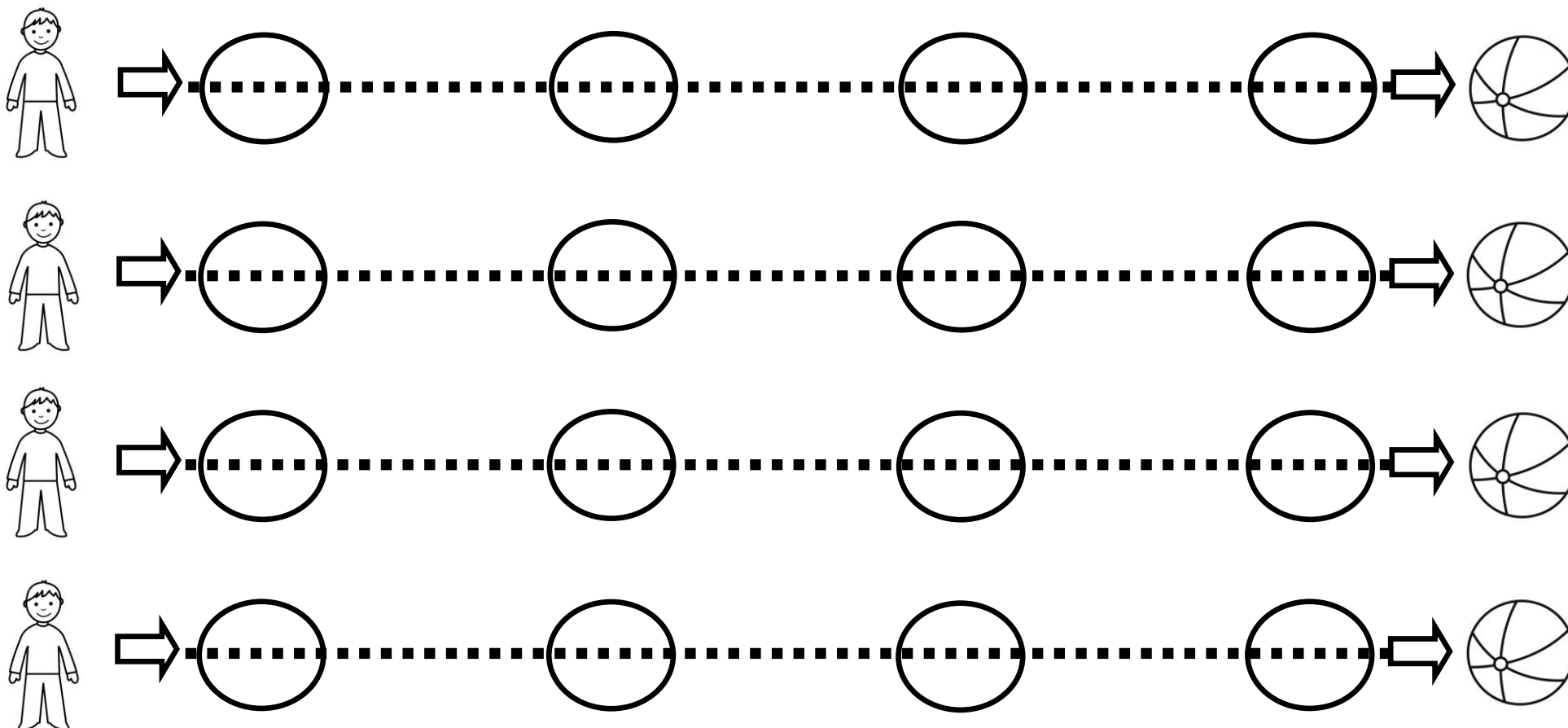

Actividades para mejorar motricidad fina

Sigue con tu lápiz los círculos para unir al niño con su balón

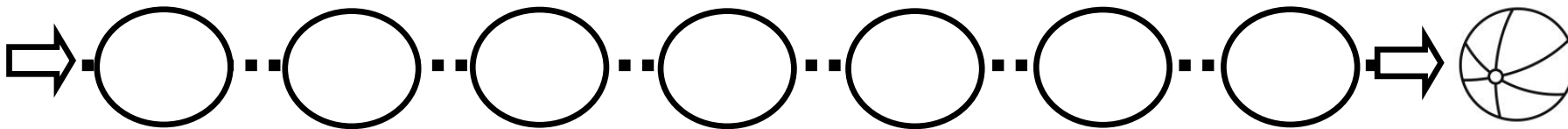
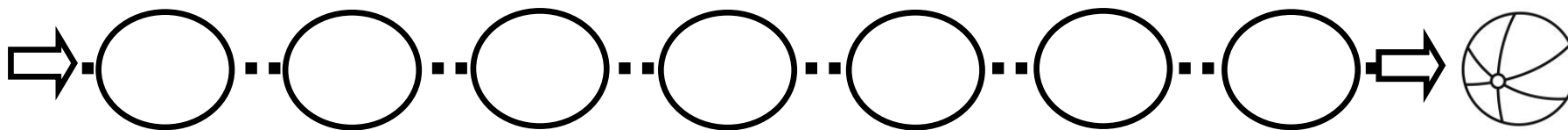
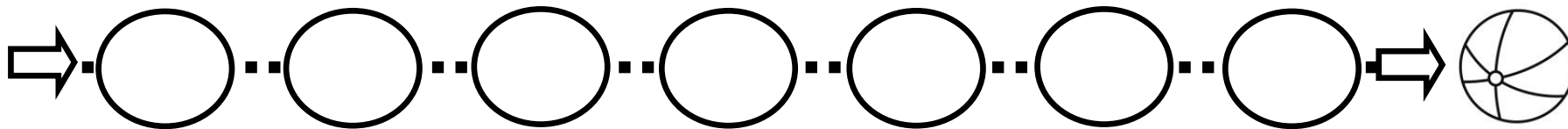
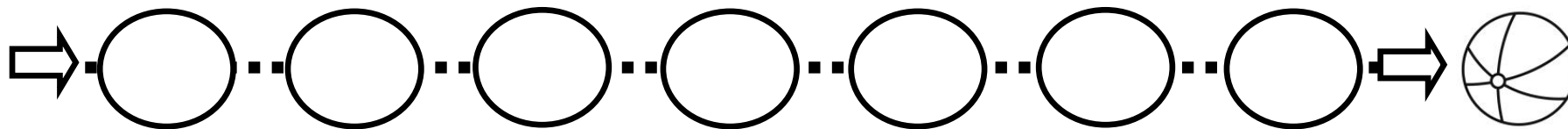

Actividades para mejorar motricidad fina

Sigue con tu lápiz los círculos para unir al niño con su balón

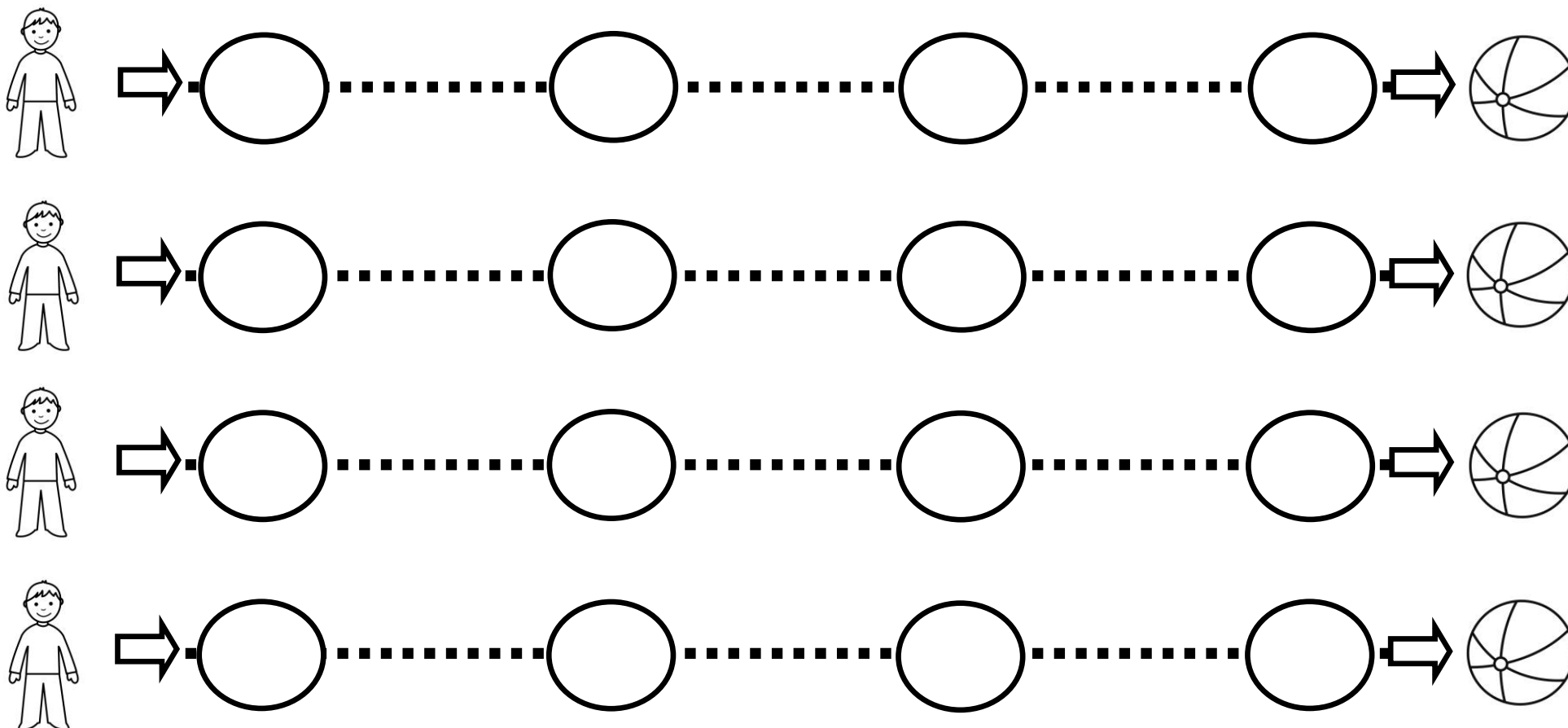

Actividades para mejorar motricidad fina

Sigue con tu lápiz los círculos para unir al niño con su balón

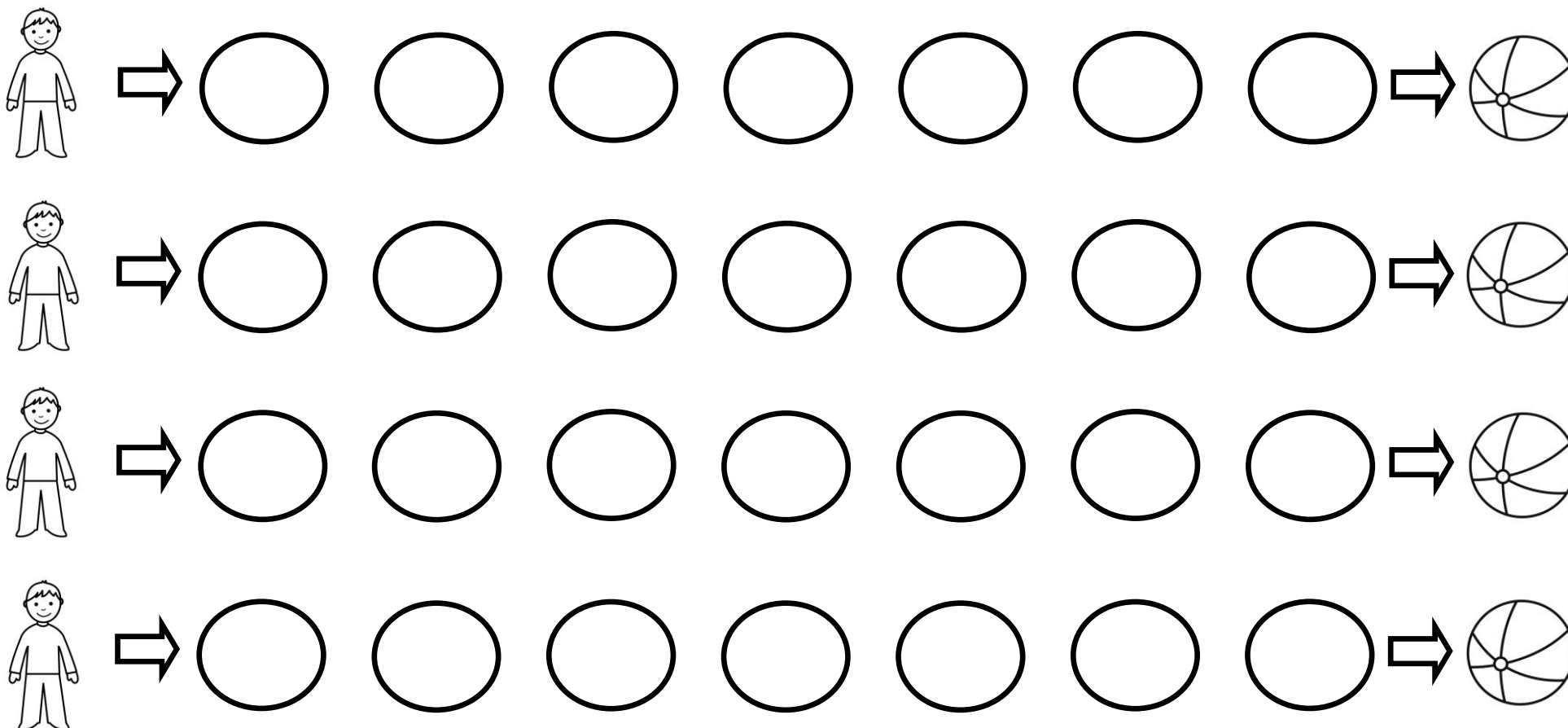

Actividades para mejorar motricidad fina

Sigue con tu lápiz los círculos para unir al niño con su balón

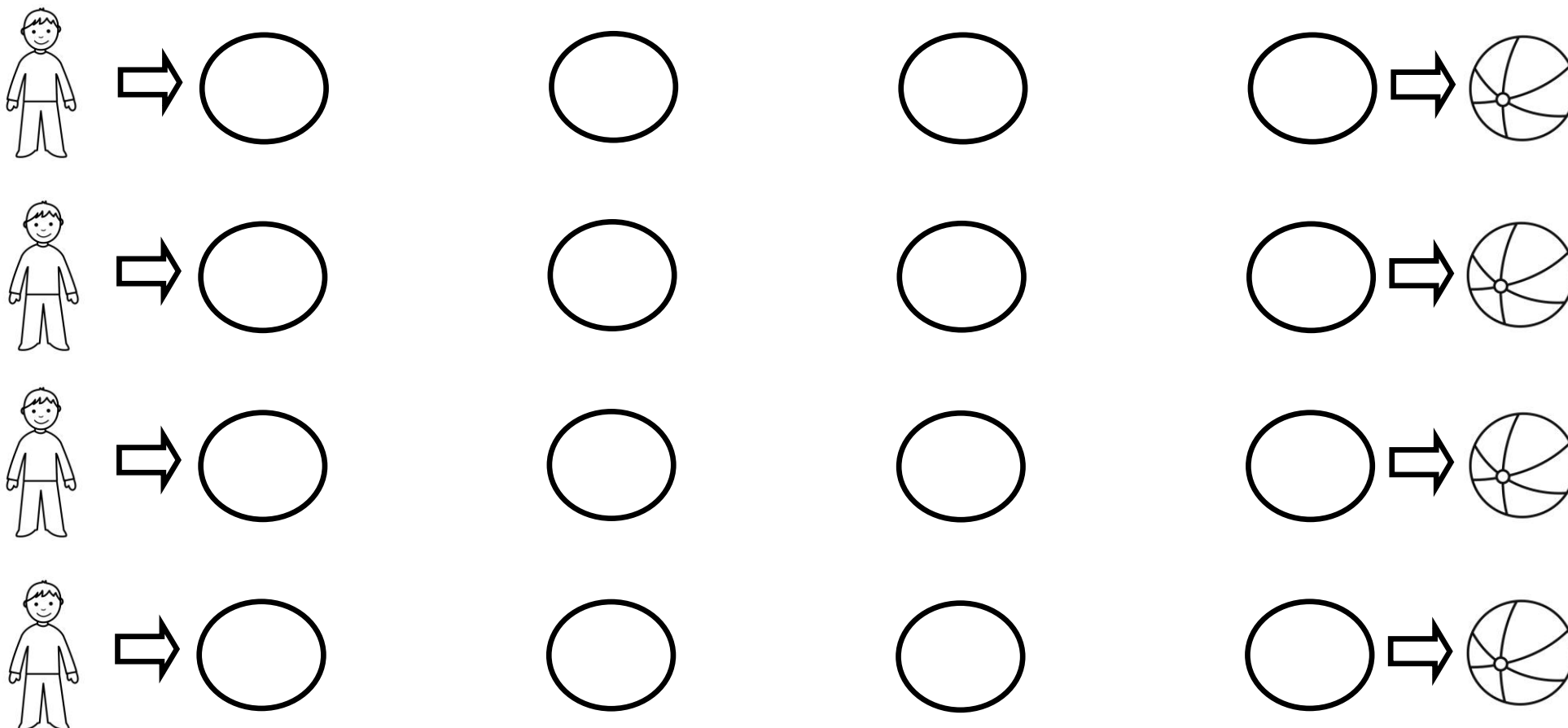

Actividades para mejorar motricidad fina

Sigue con tu lápiz los rayos para unir a nube y la tierra

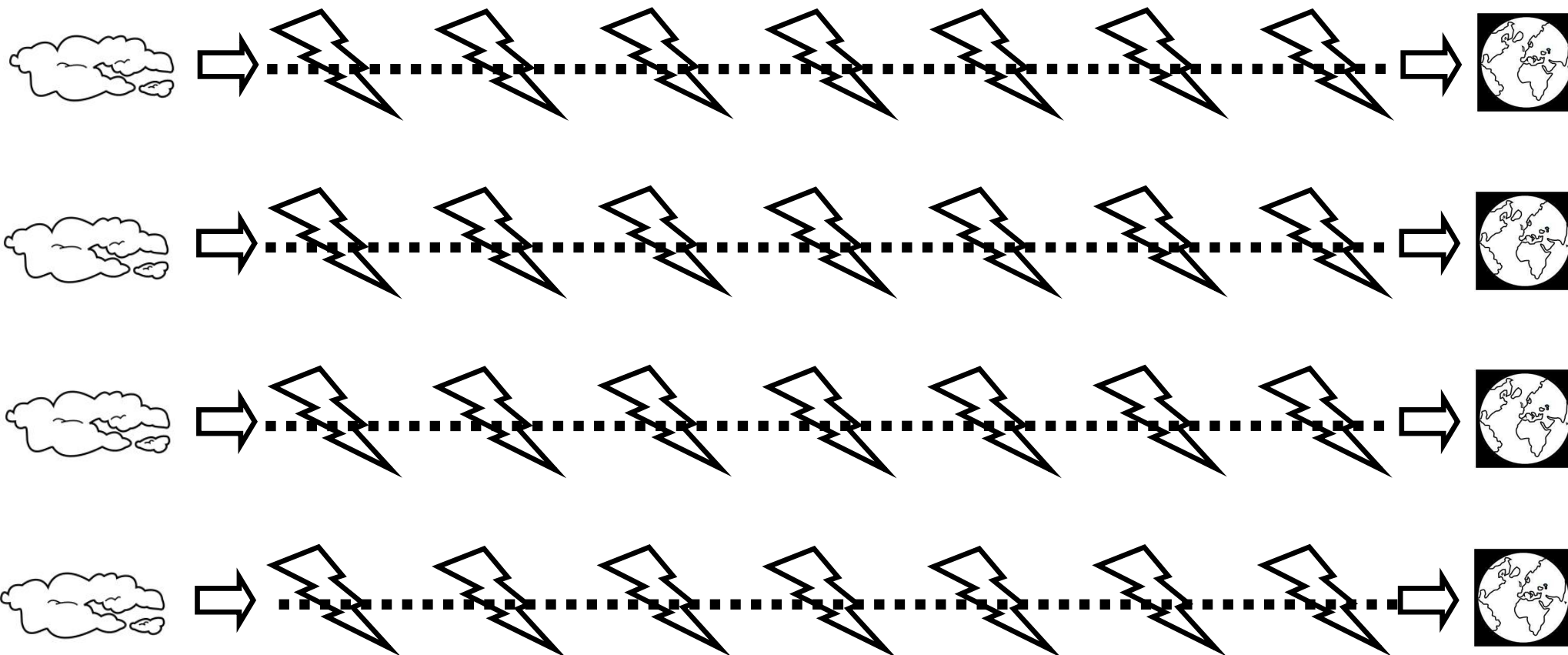

Actividades para mejorar motricidad fina

Sigue con tu lápiz los rayos para unir a nube y la tierra

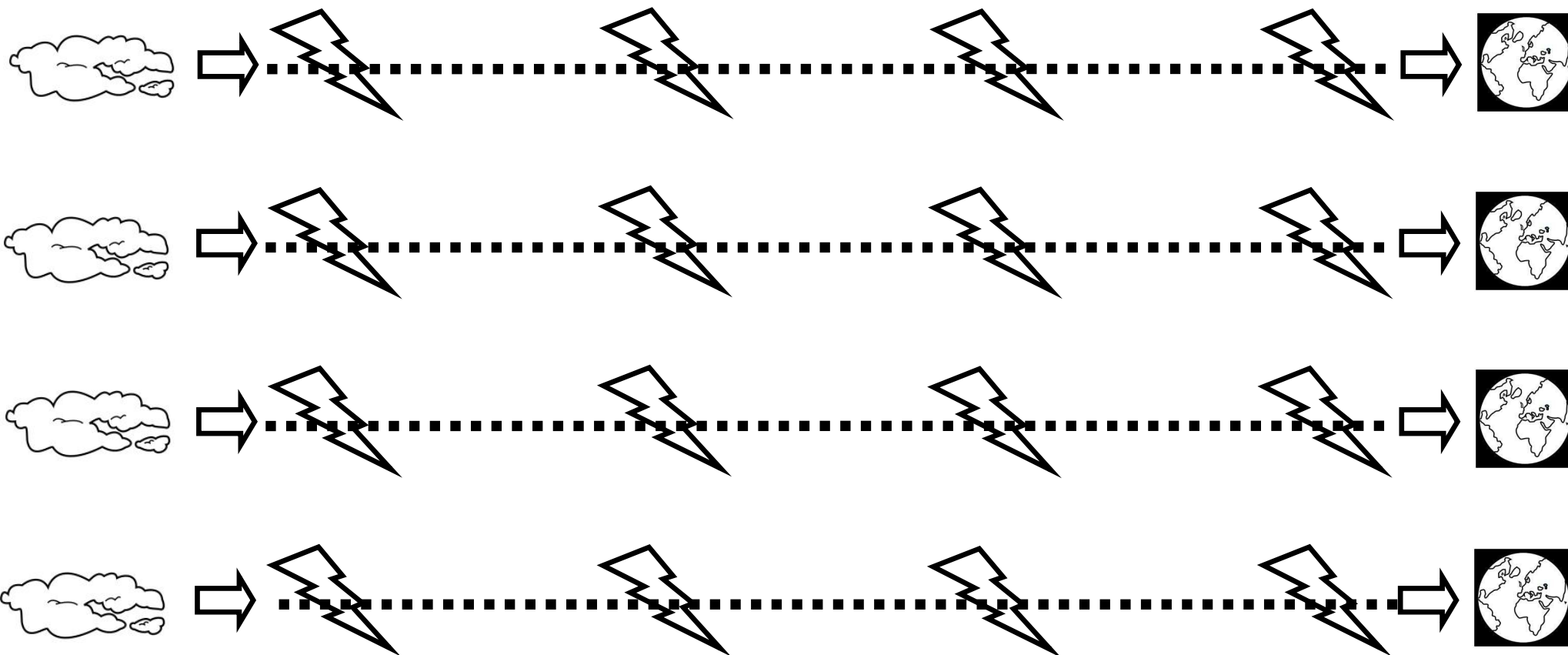

Actividades para mejorar motricidad fina

Sigue con tu lápiz los rayos para unir a nube y la tierra

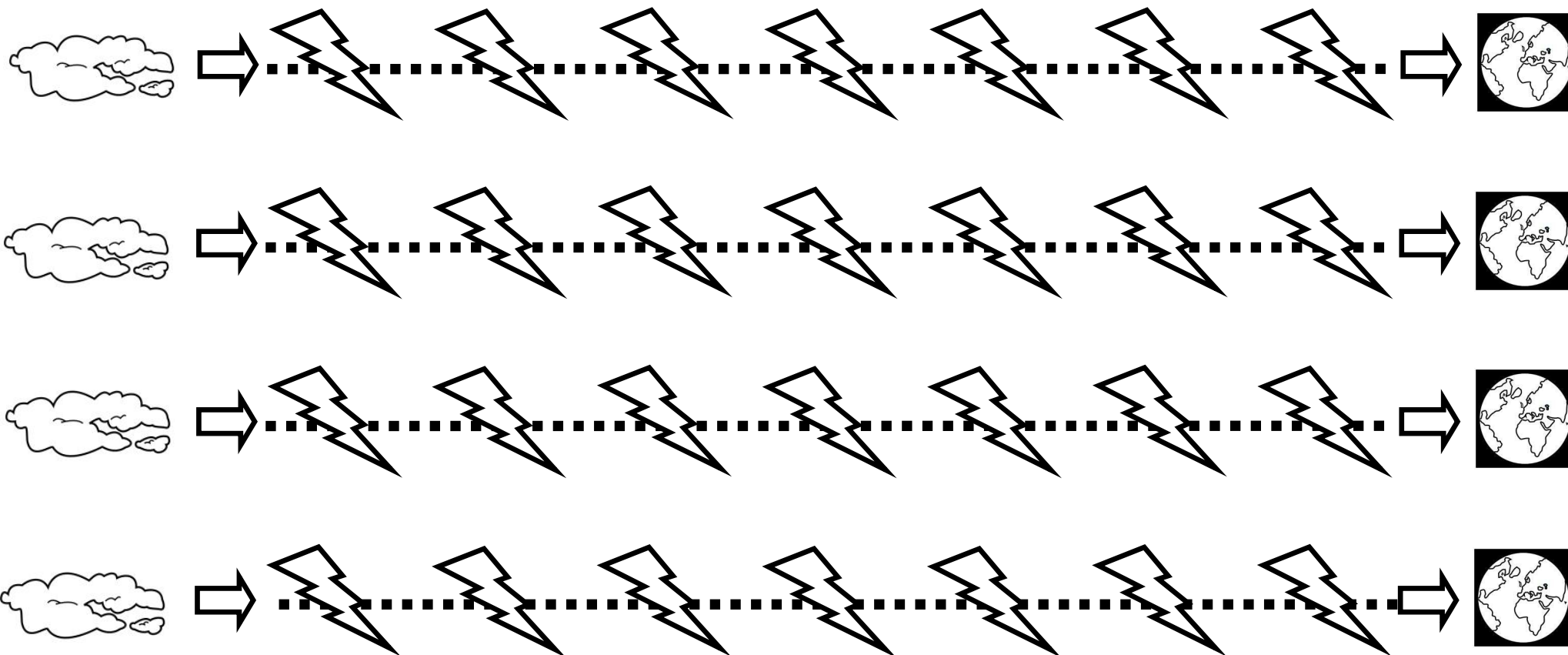

Actividades para mejorar motricidad fina

Sigue con tu lápiz los rayos para unir a nube y la tierra

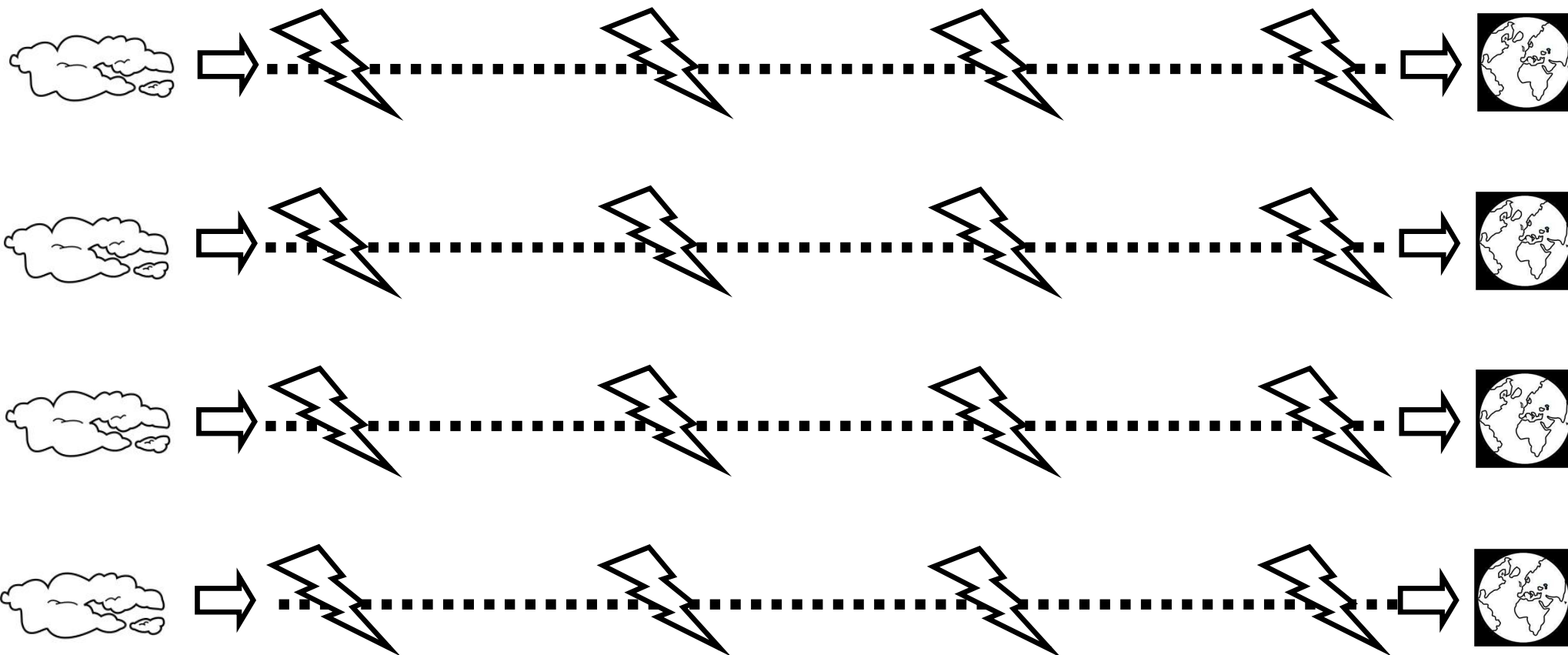

Actividades para mejorar motricidad fina

Sigue con tu lápiz los rayos para unir a nube y la tierra

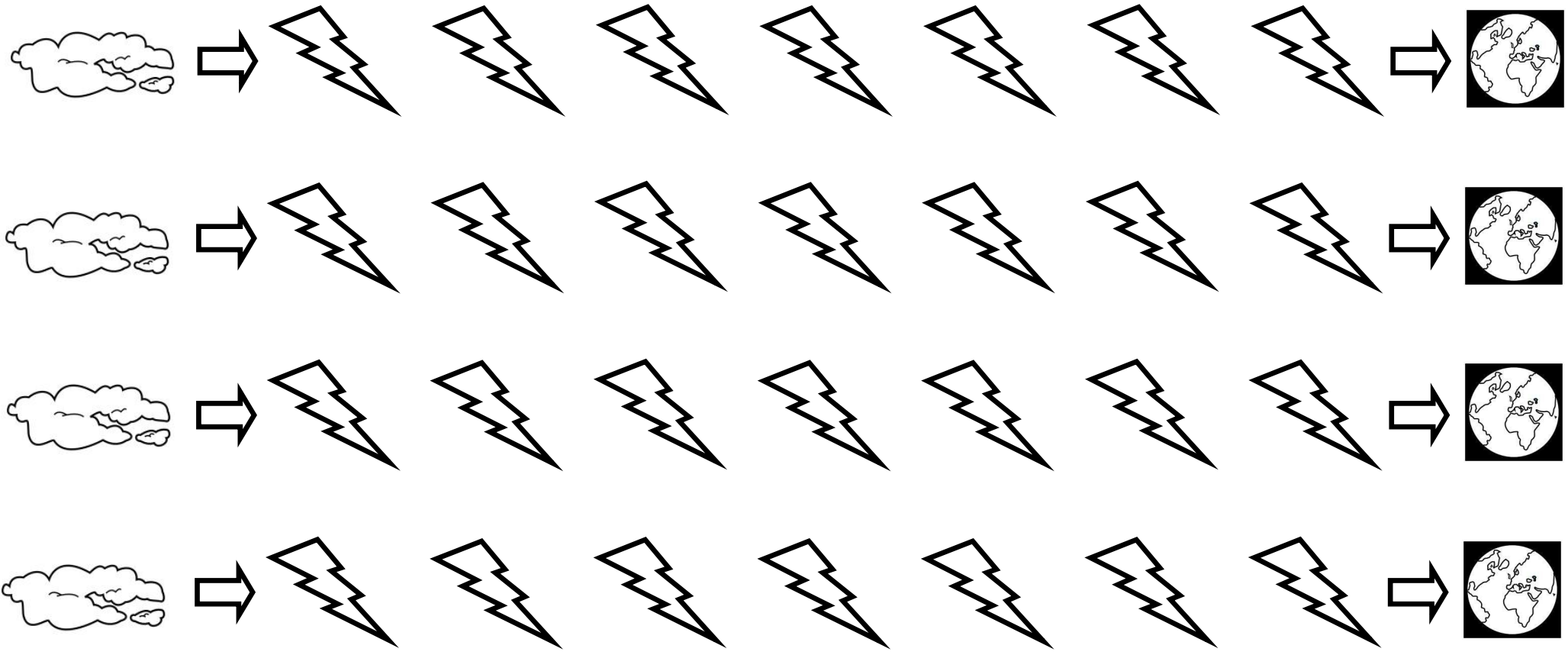

Actividades para mejorar motricidad fina

Sigue con tu lápiz los rayos para unir a nube y la tierra

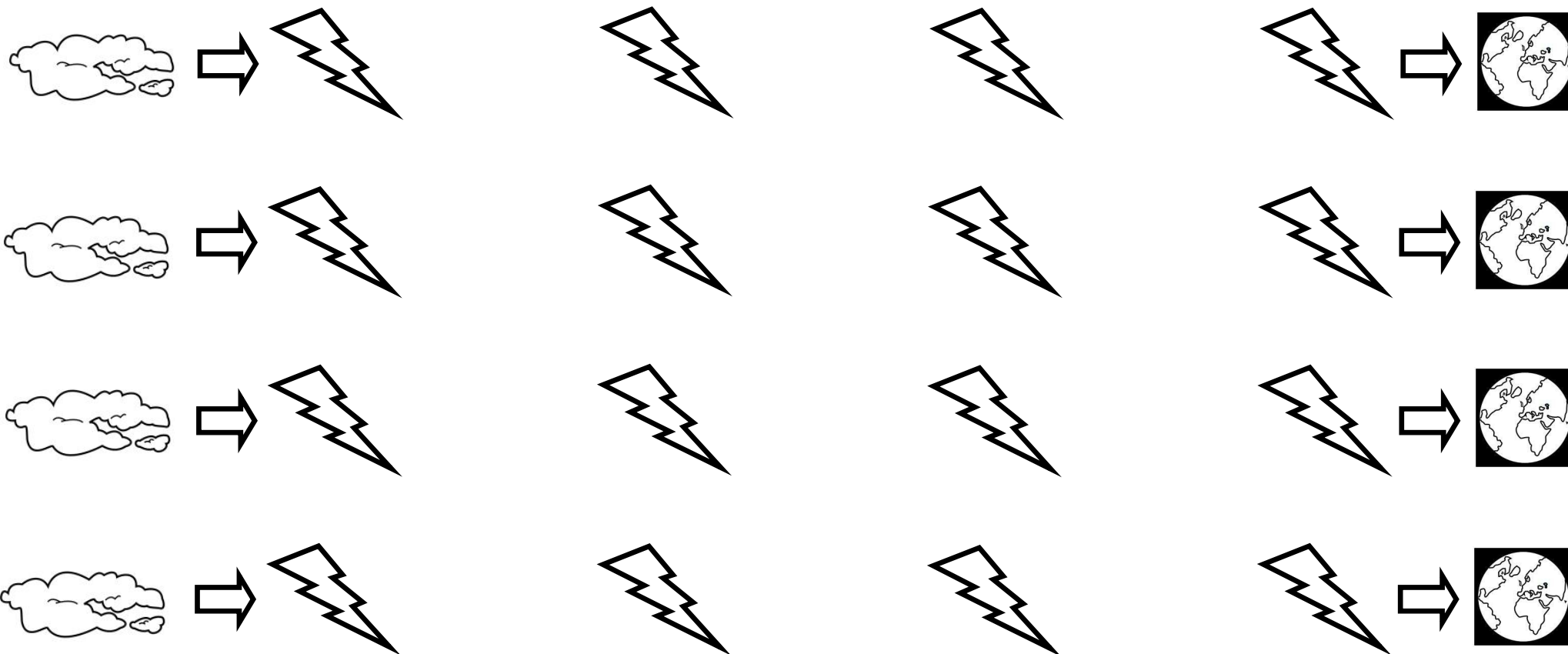

Actividades para mejorar motricidad fina

Sigue con tu lápiz las estrellitas para ir desde el sol a la tierra

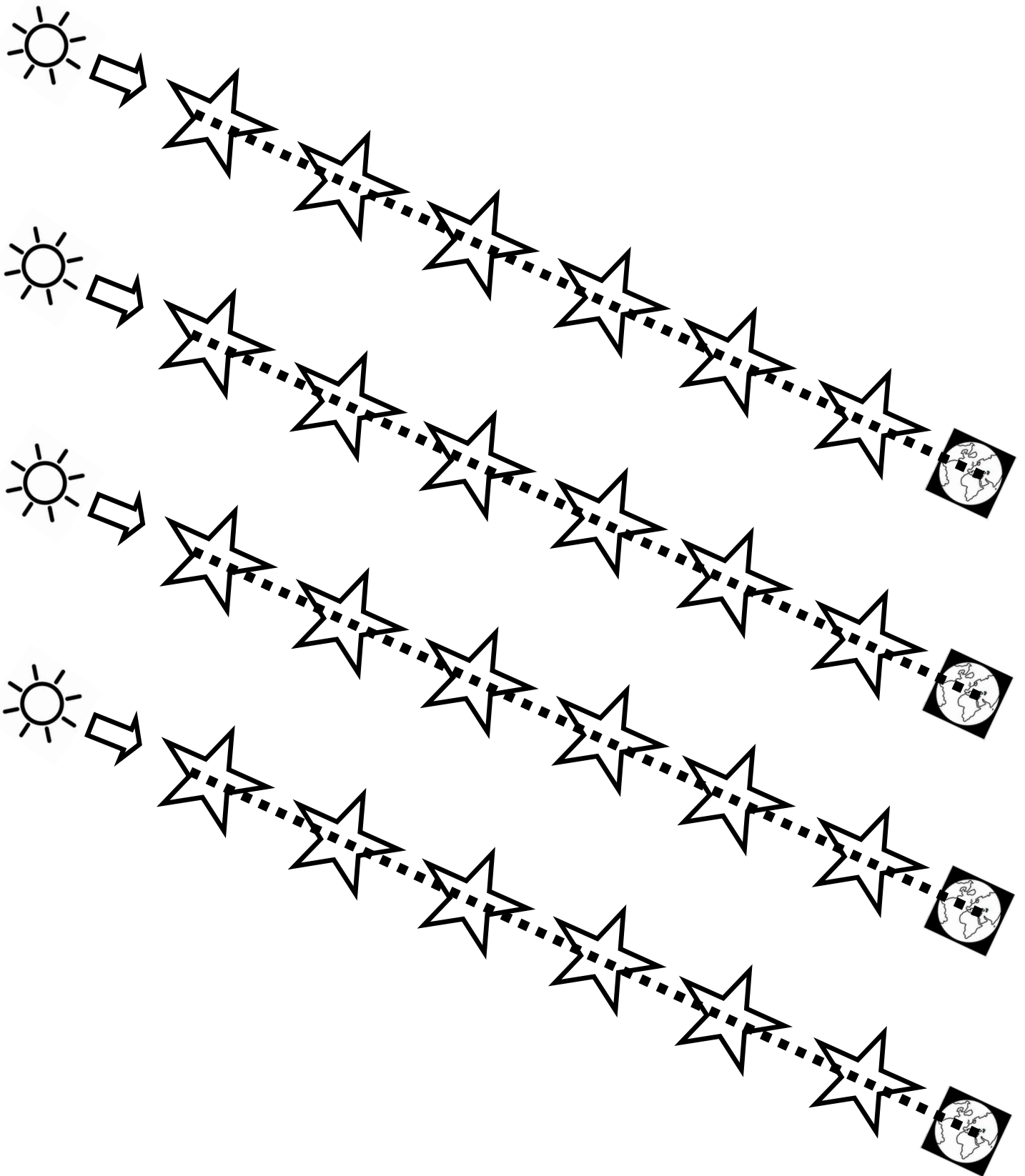

Actividades para mejorar motricidad fina

Sigue con tu lápiz las estrellitas para ir desde el sol a la tierra

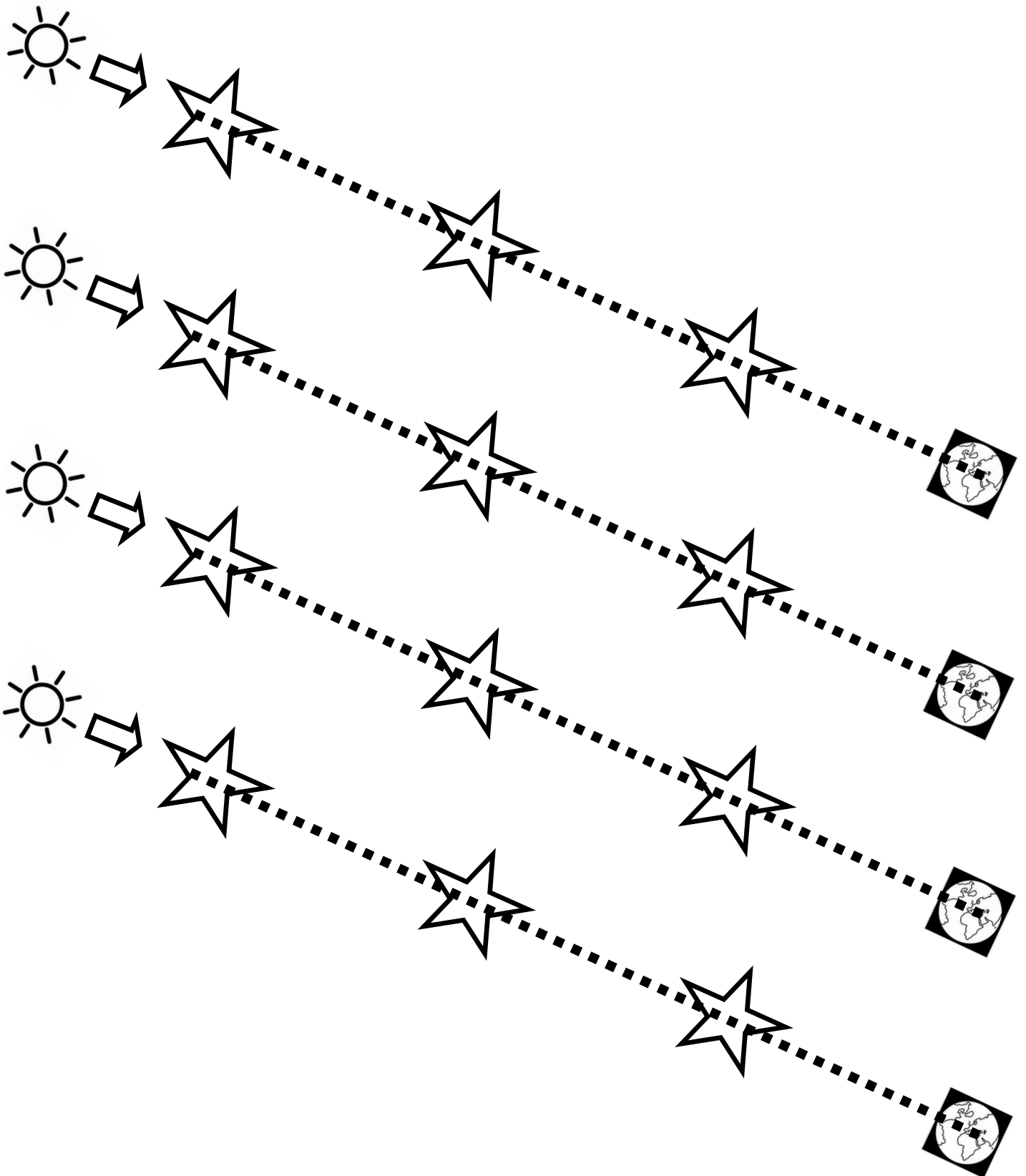

Actividades para mejorar motricidad fina

Sigue con tu lápiz las estrellitas para ir desde el sol a la tierra

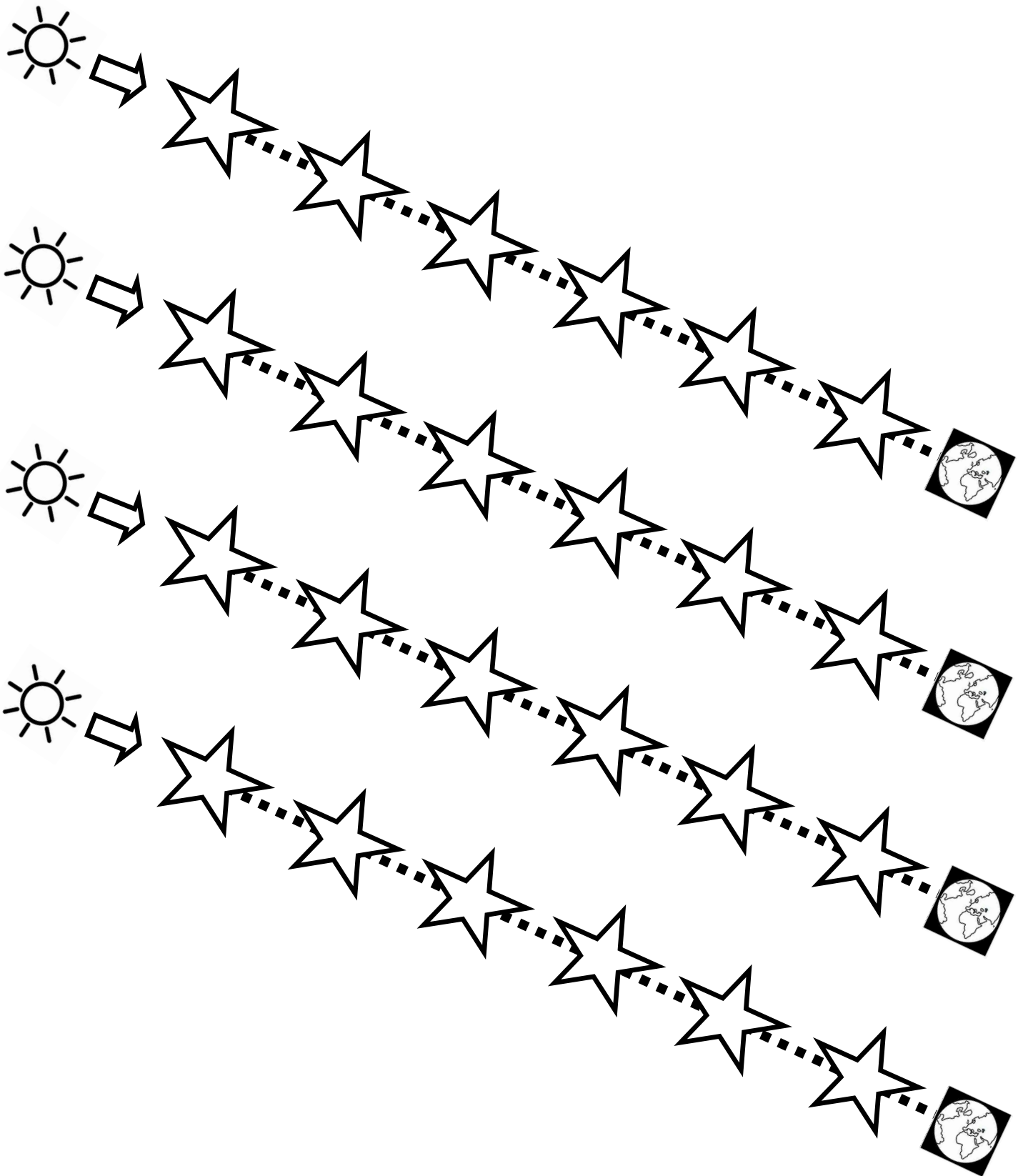

Actividades para mejorar motricidad fina

Sigue con tu lápiz las estrellitas para ir desde el sol a la tierra

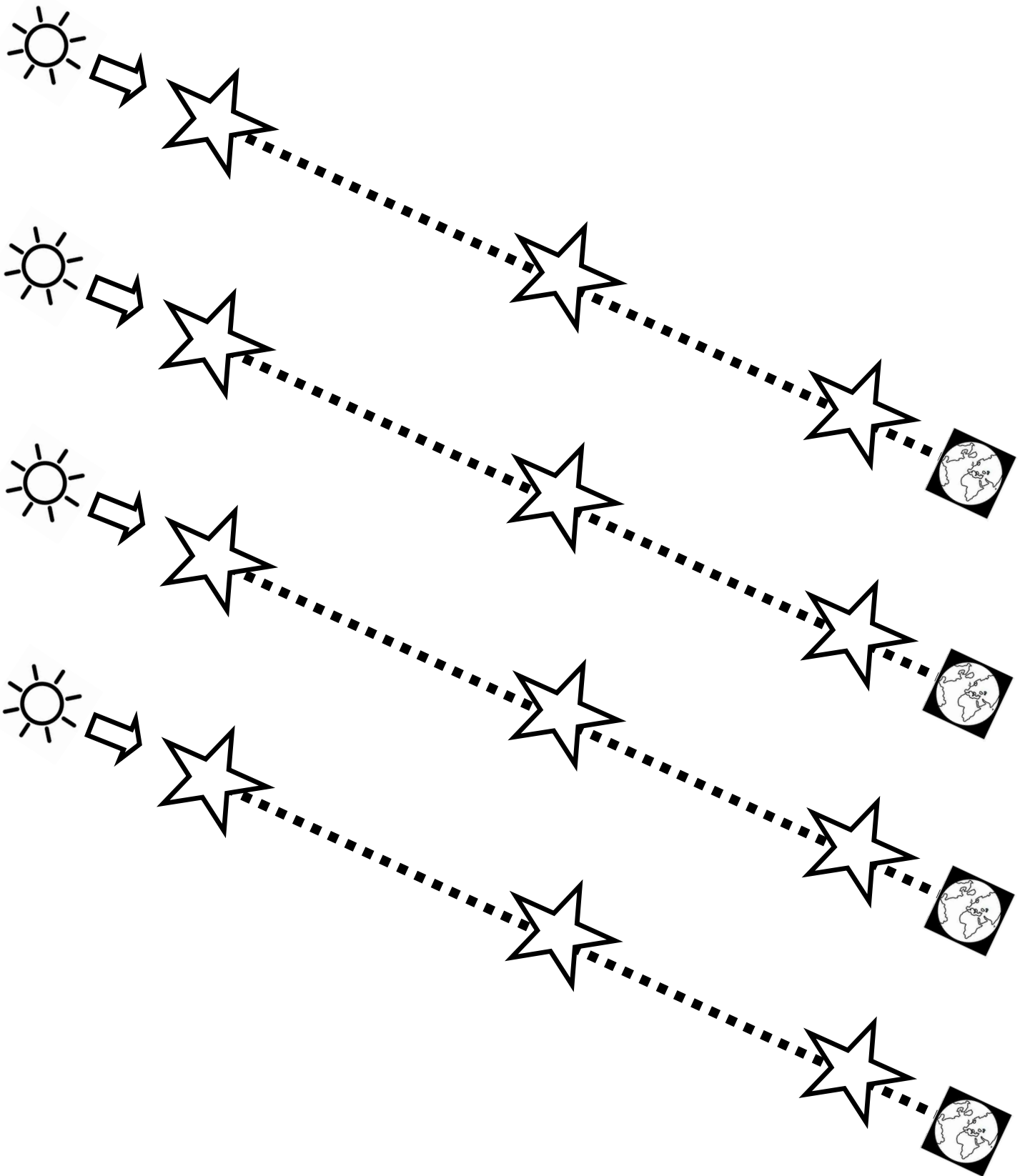

Actividades para mejorar motricidad fina

Sigue con tu lápiz las estrellitas para ir desde el sol a la tierra

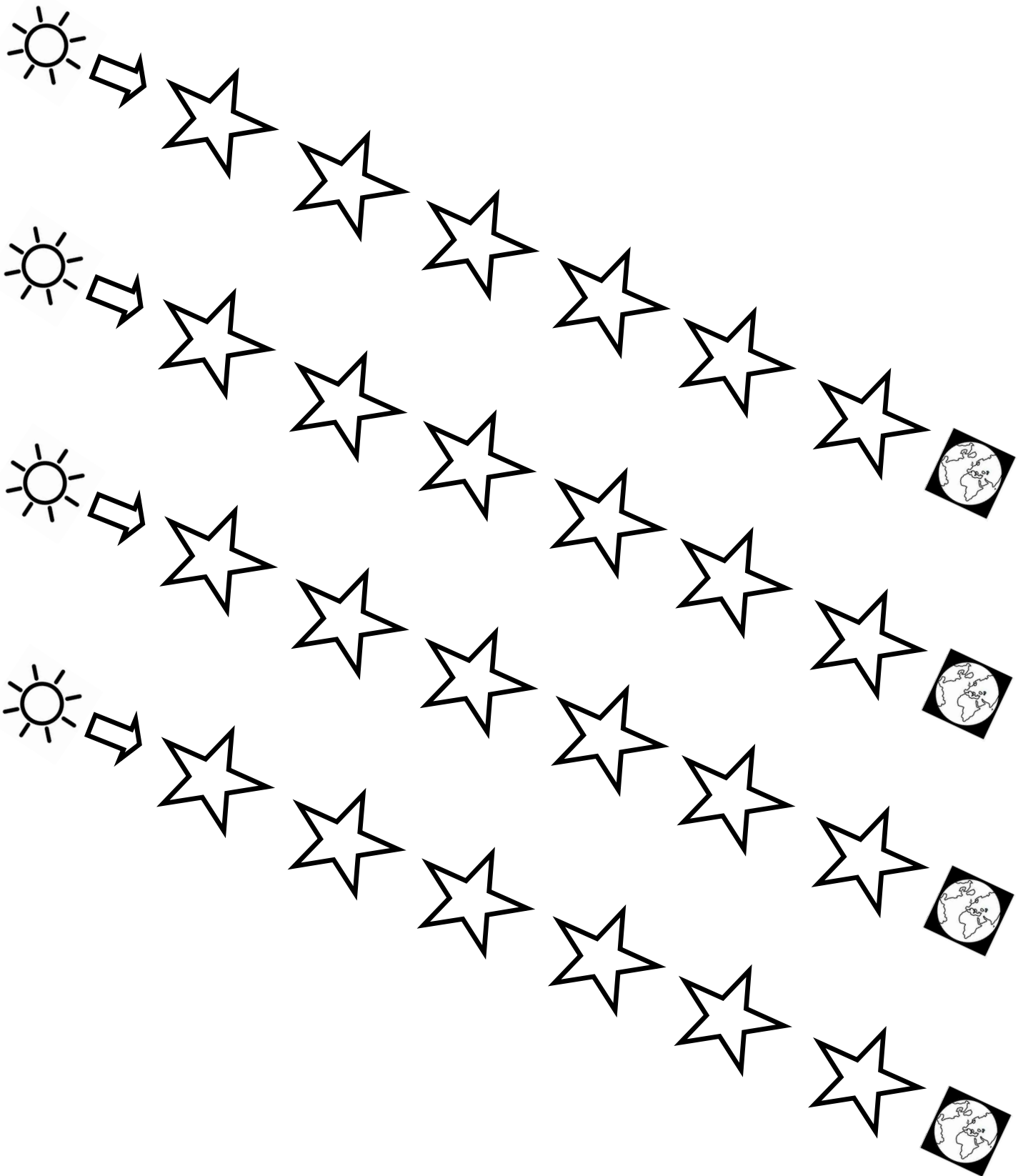

Actividades para mejorar motricidad fina

Sigue con tu lápiz las estrellitas para ir desde el sol a la tierra

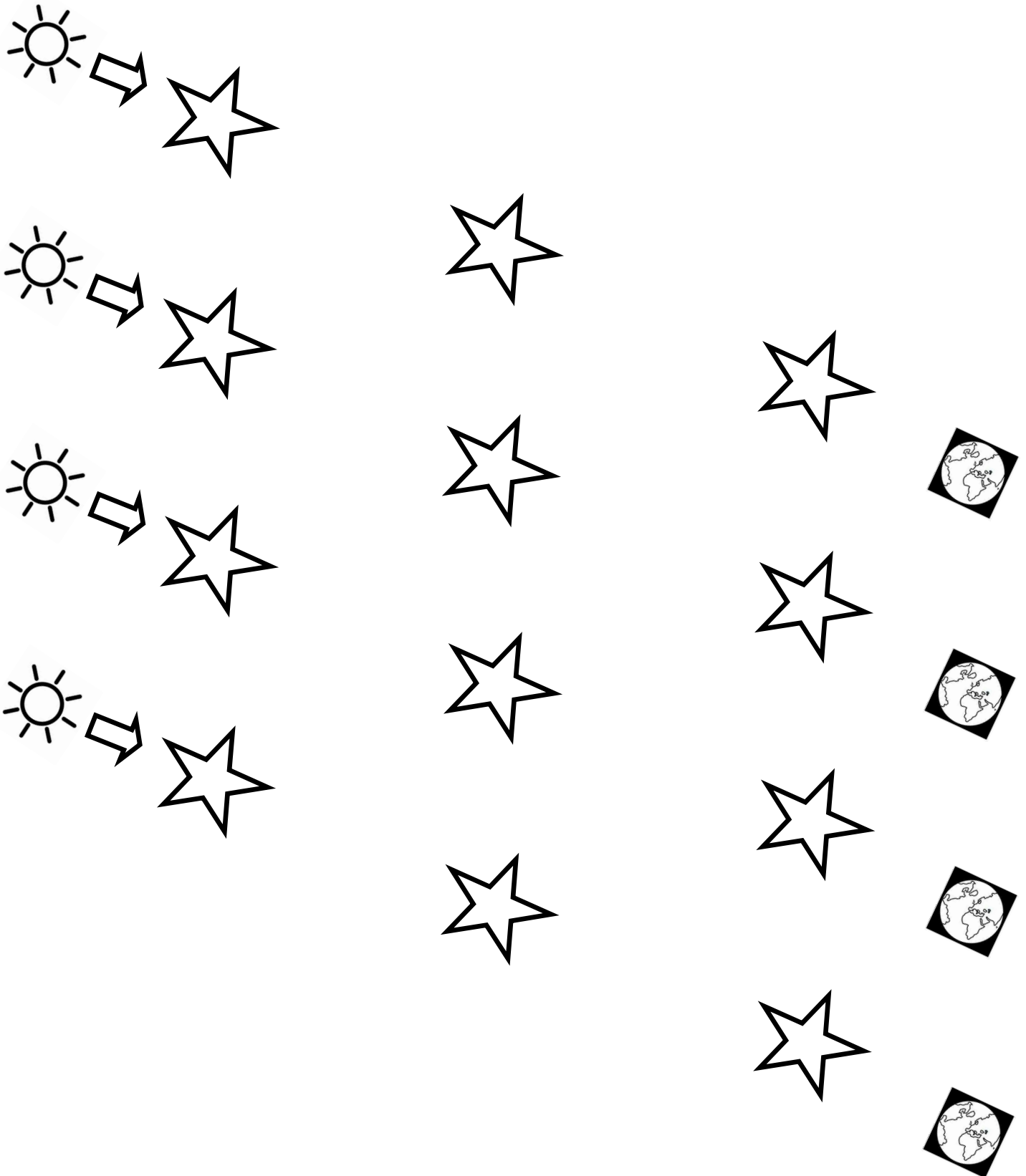

Actividades para mejorar motricidad fina

Sigue con tu lápiz los corazones para unir a la mama y a su bebe

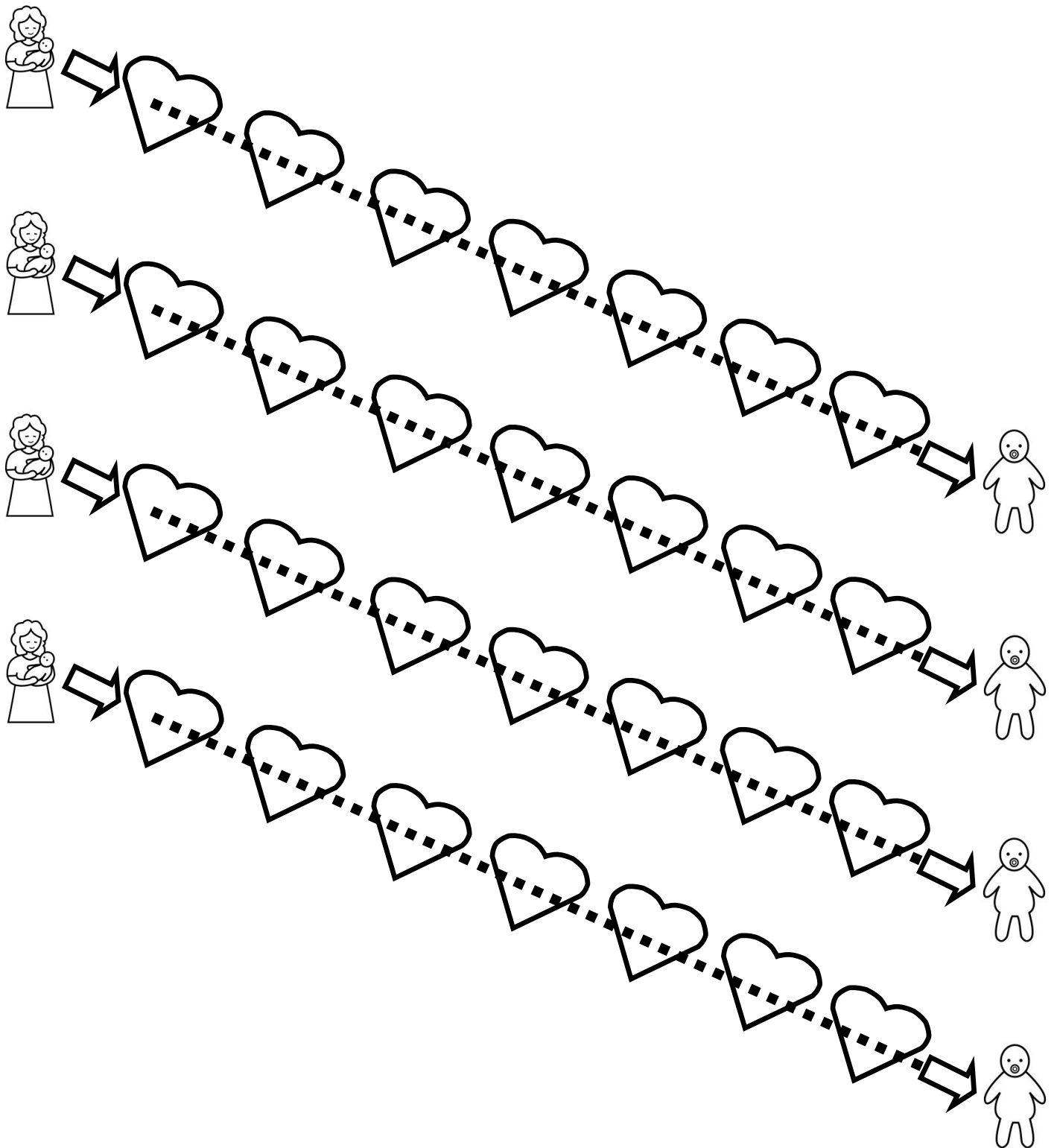

Actividades para mejorar motricidad fina

Sigue con tu lápiz los corazones para unir a la mama y a su bebe

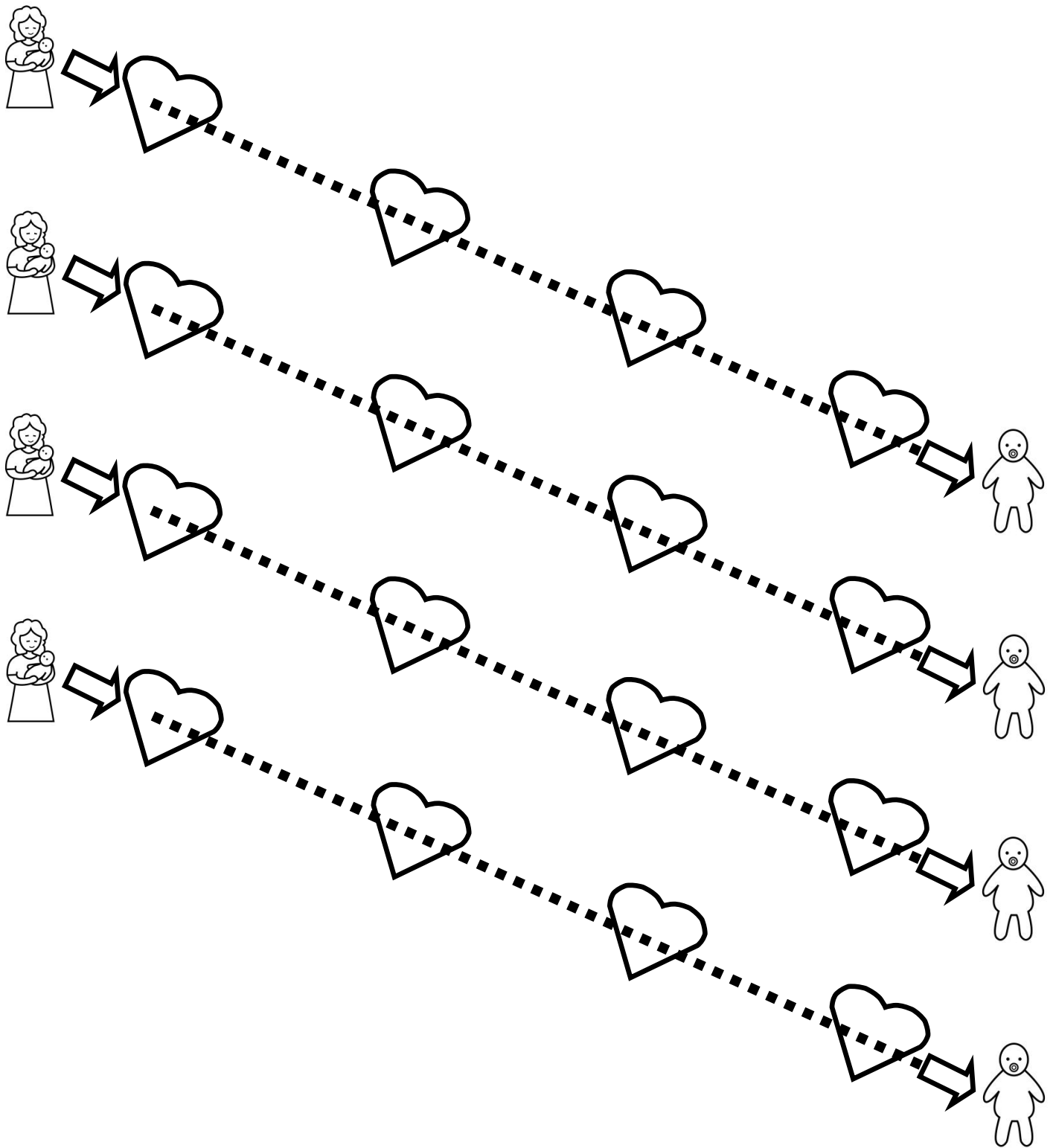

Actividades para mejorar motricidad fina

Sigue con tu lápiz los corazones para unir a la mama y a su bebe

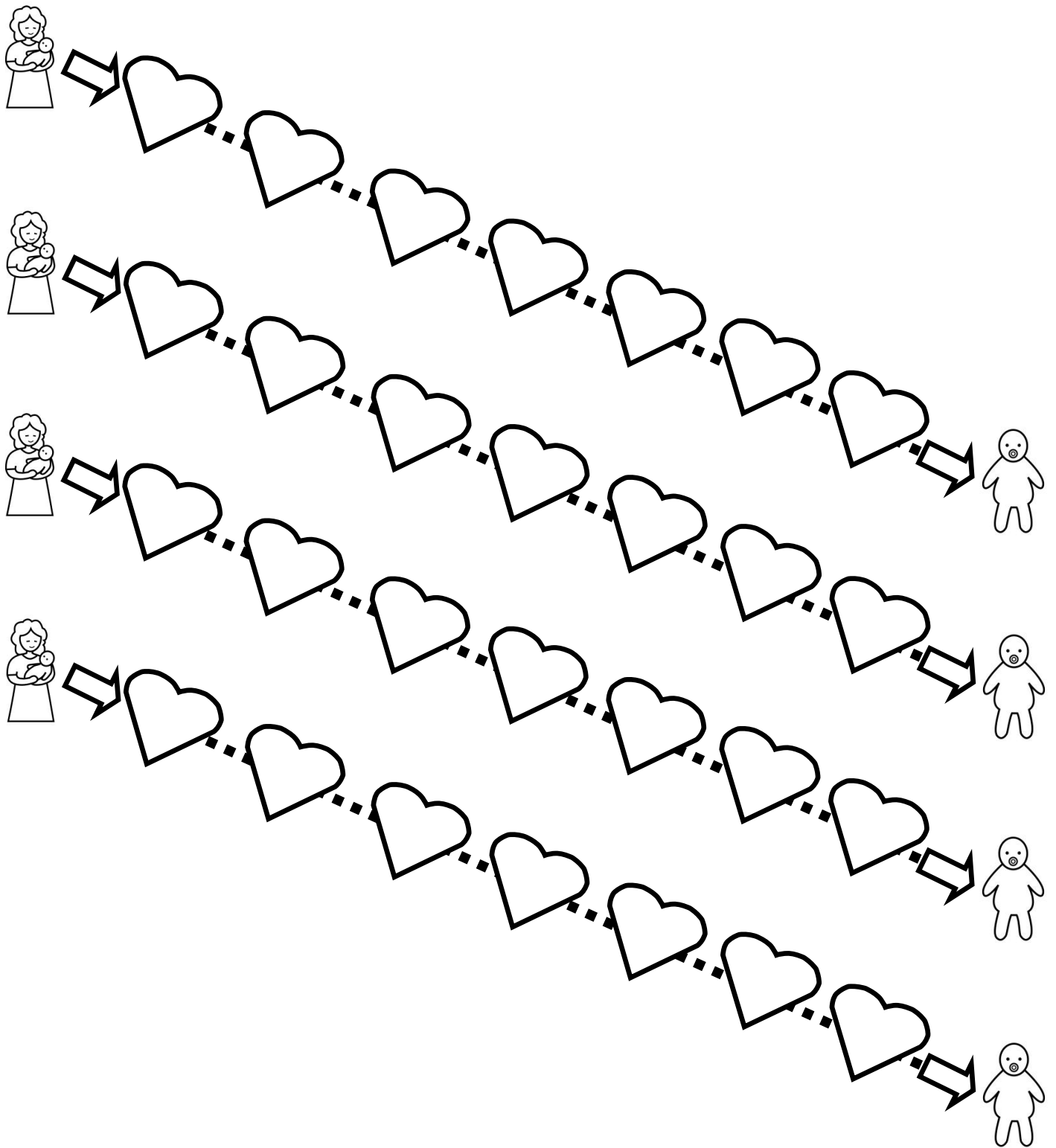

Actividades para mejorar motricidad fina

Sigue con tu lápiz los corazones para unir a la mama y a su bebe

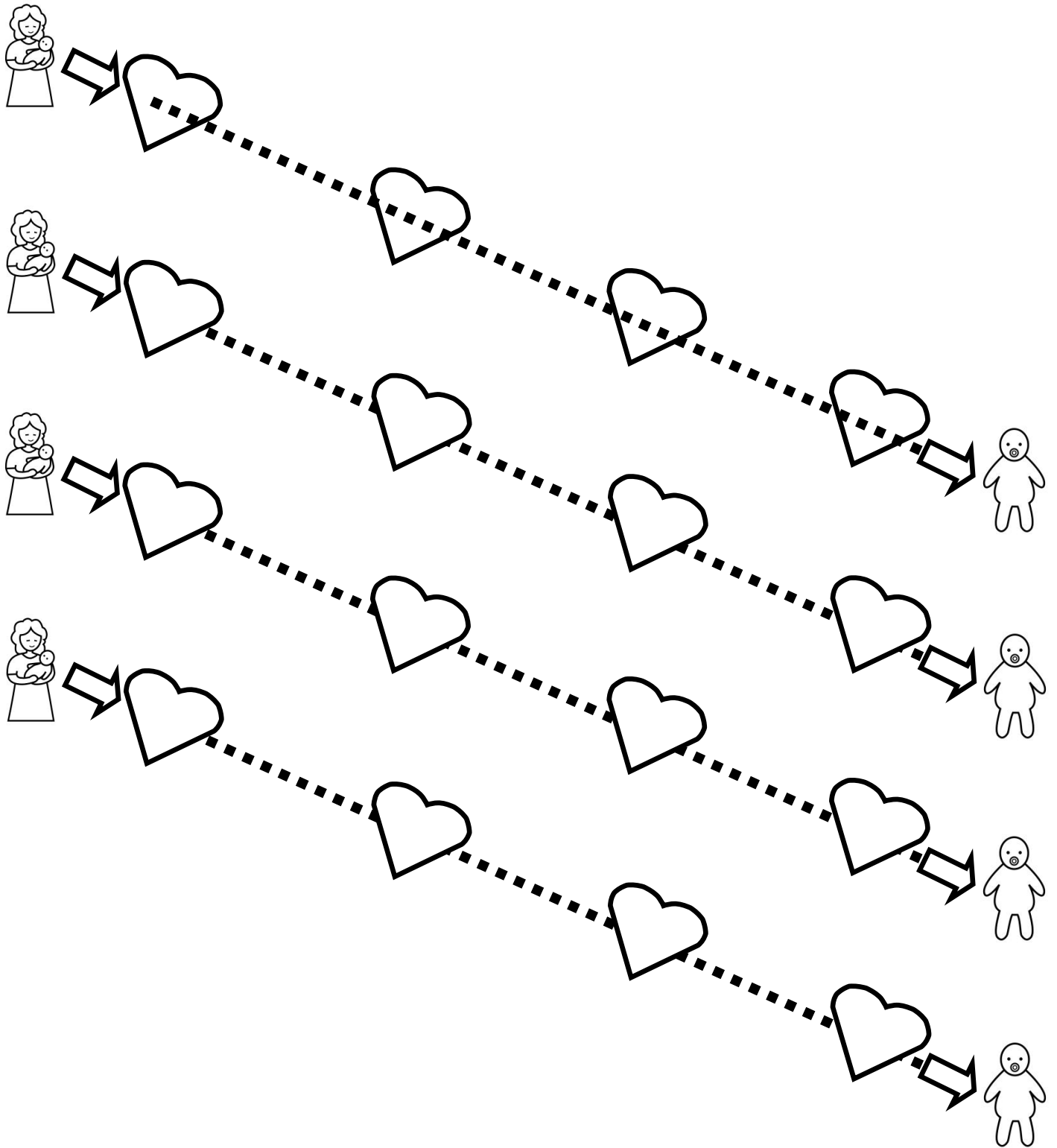

Actividades para mejorar motricidad fina

Sigue con tu lápiz los corazones para unir a la mama y a su bebe

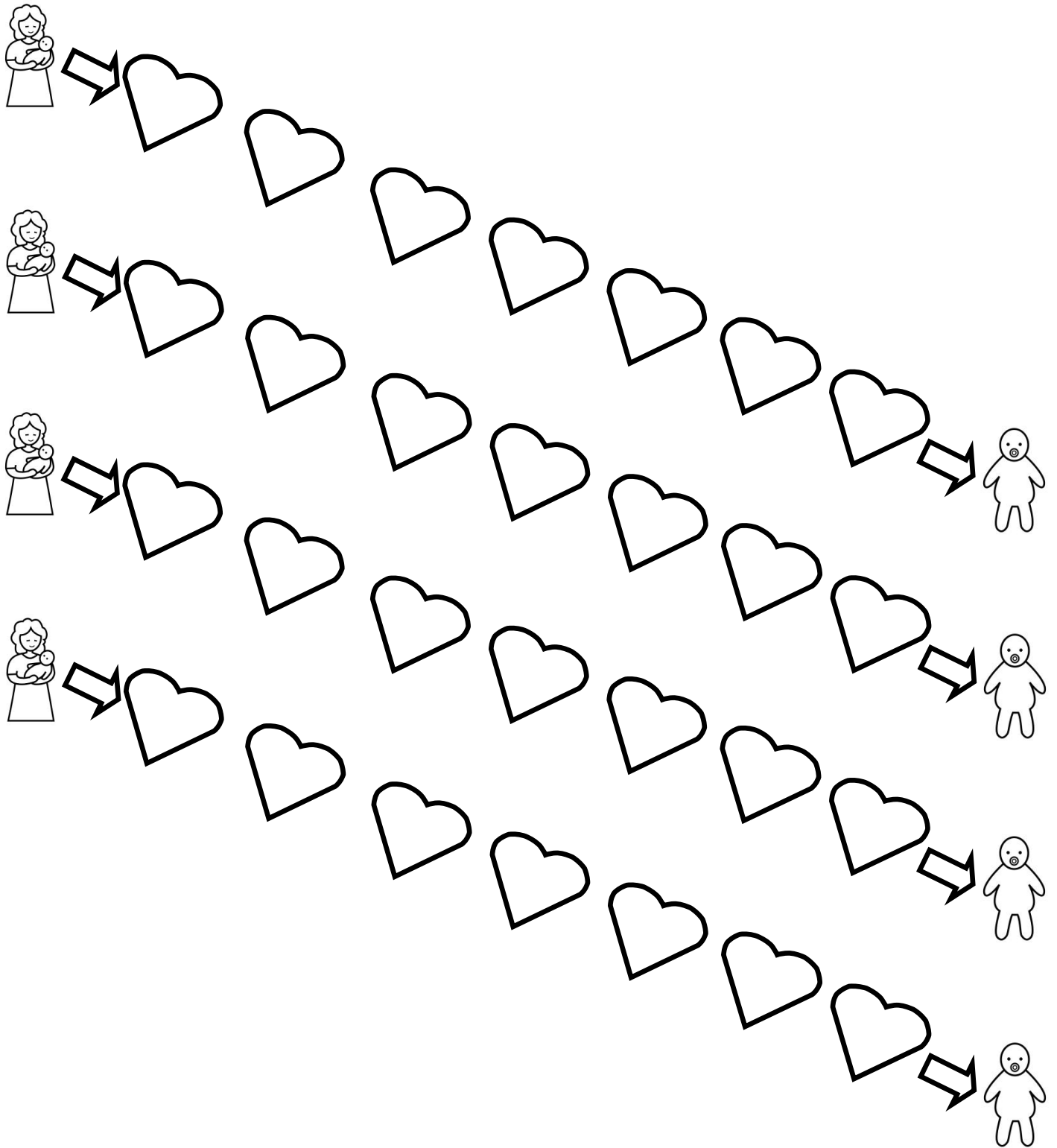

Actividades para mejorar motricidad fina

Sigue con tu lápiz los corazones para unir a la mama y a su bebe

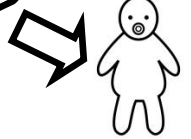
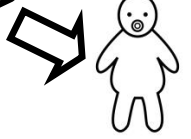
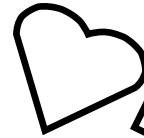
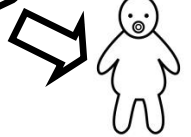
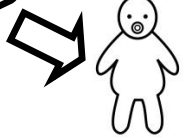
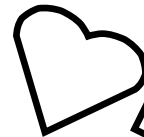
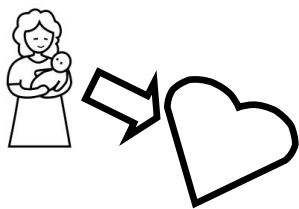
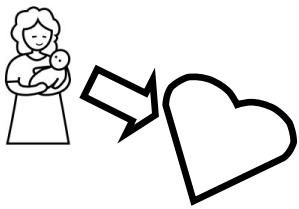
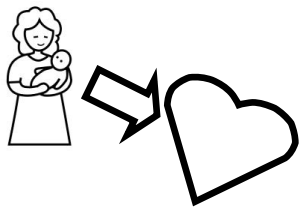
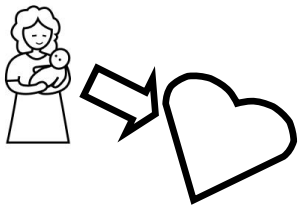

Actividades para mejorar motricidad fina

Sigue con tu lápiz las caras para unir al niño con su amiga

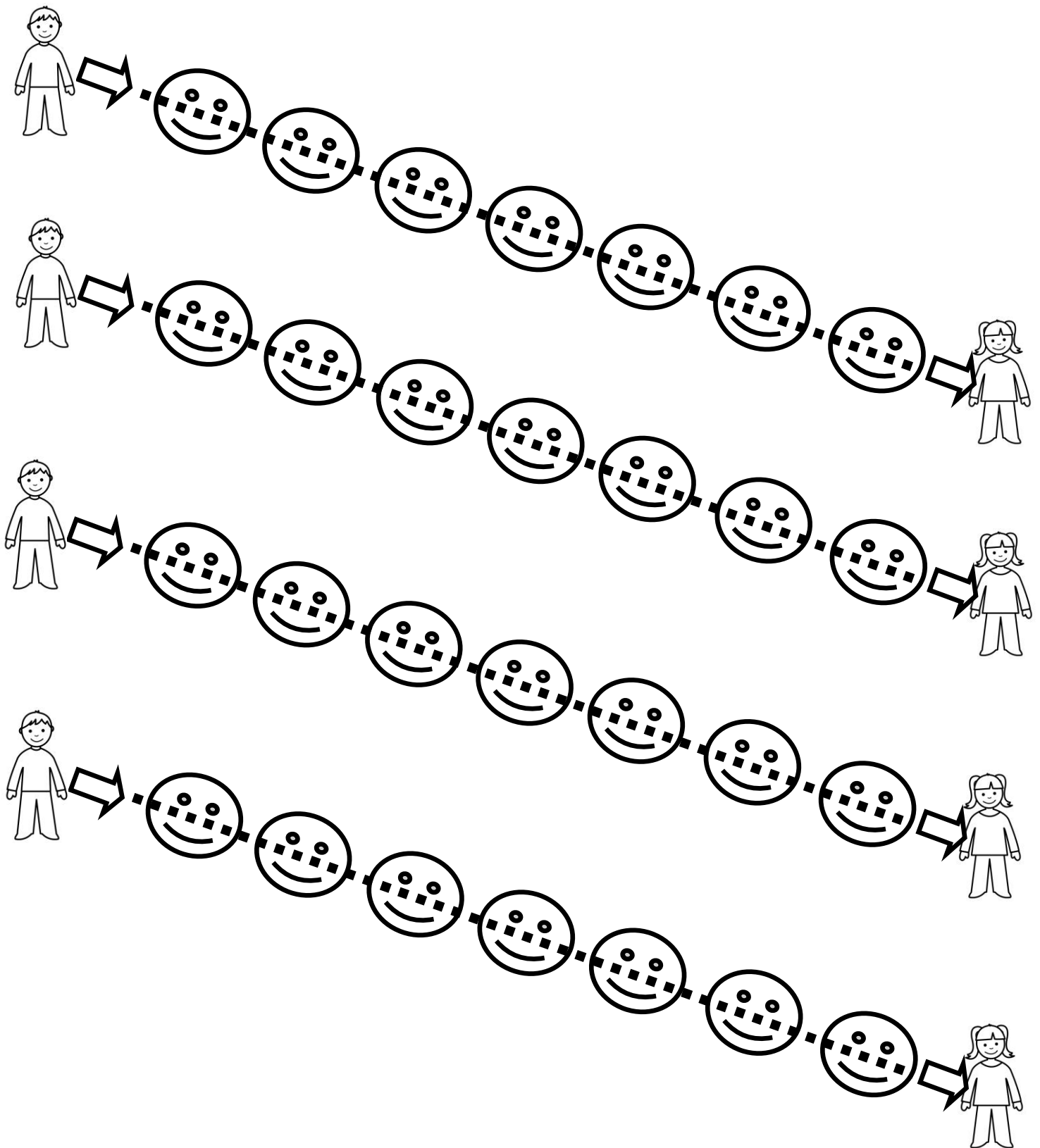

Actividades para mejorar motricidad fina

Sigue con tu lápiz las caras para unir al niño con su amiga

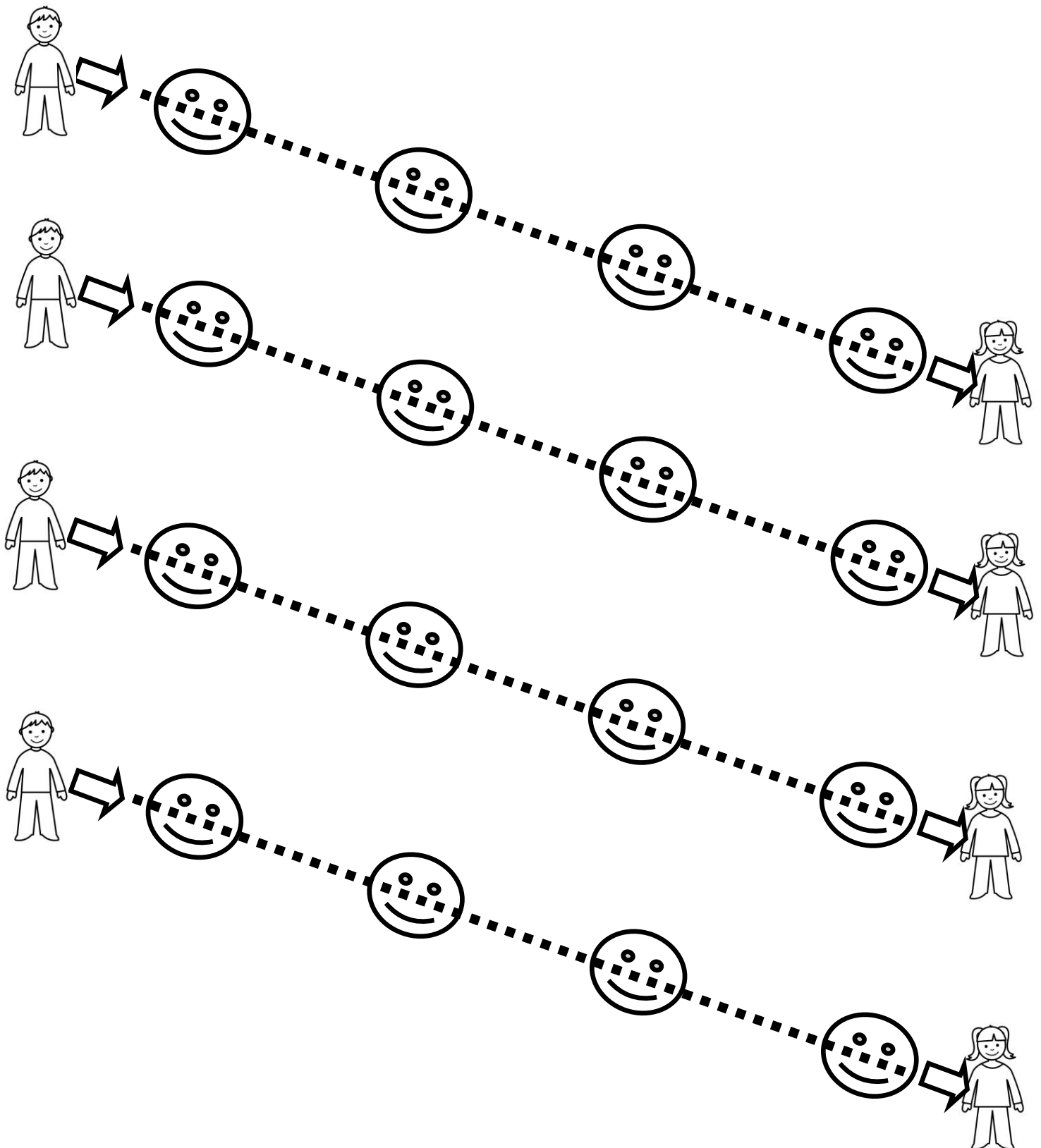

Actividades para mejorar motricidad fina

Sigue con tu lápiz las caras para unir al niño con su amiga

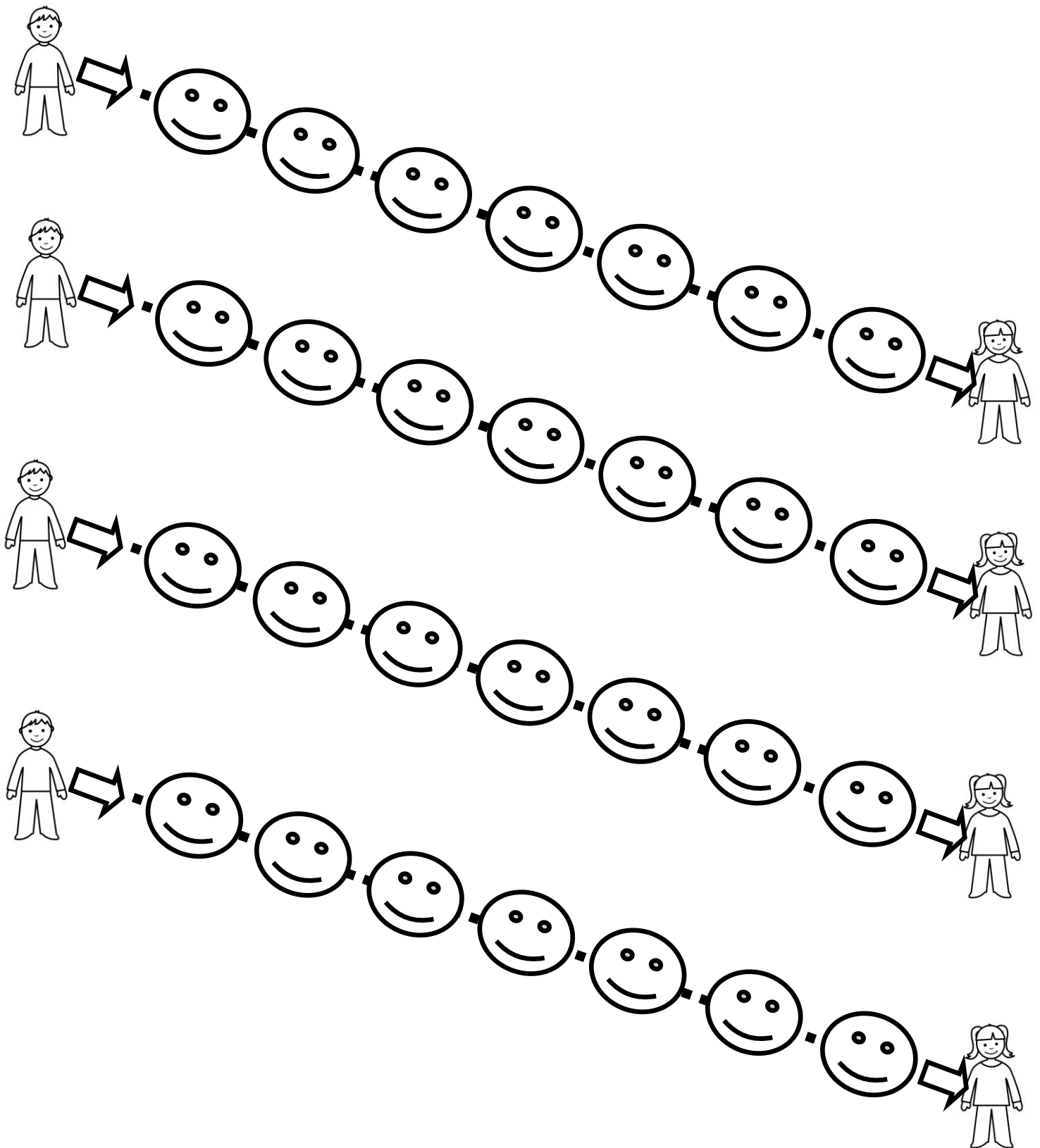

Actividades para mejorar motricidad fina

Sigue con tu lápiz las caras para unir al niño con su amiga

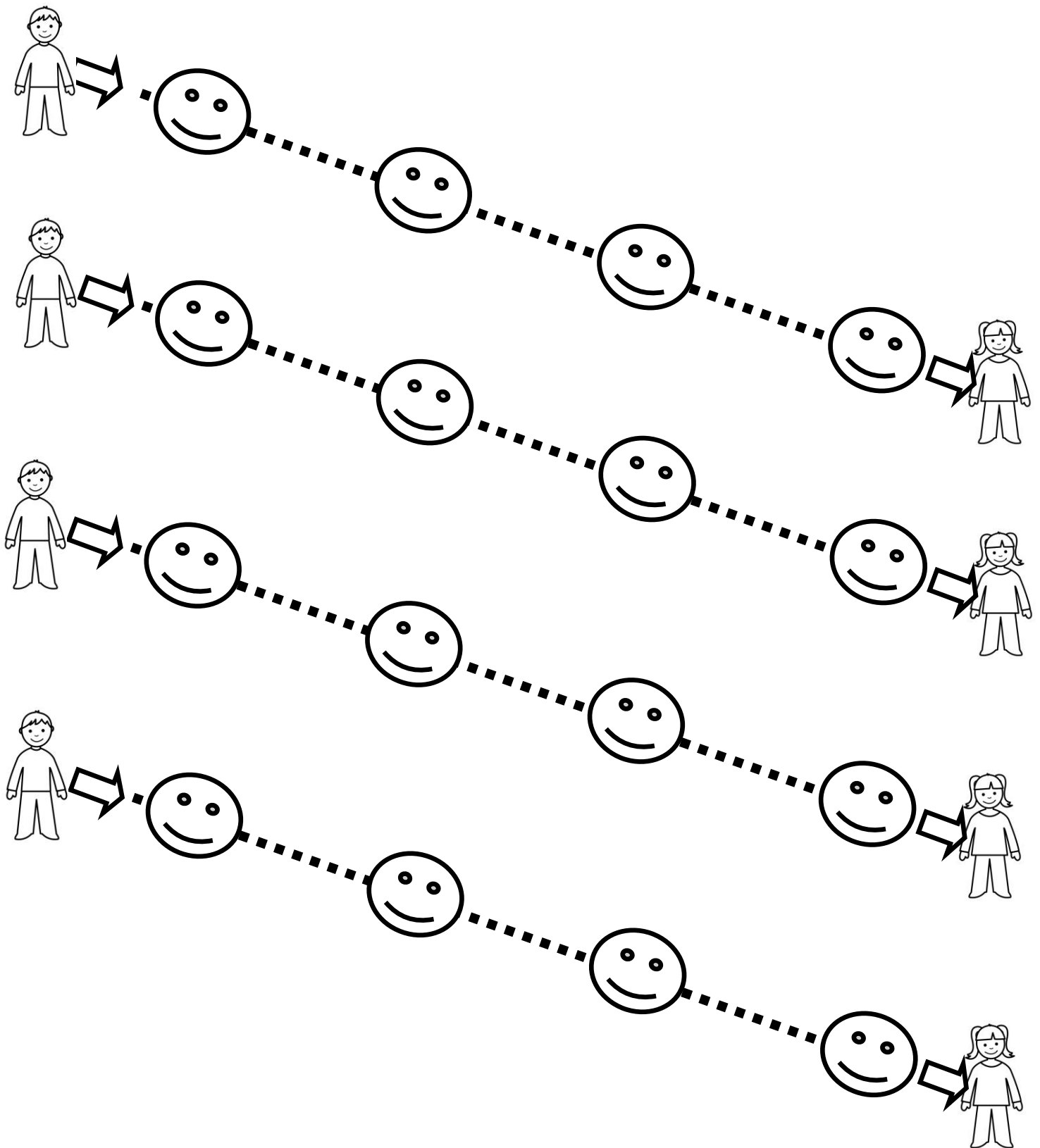

Actividades para mejorar motricidad fina

Sigue con tu lápiz las caras para unir al niño con su amiga

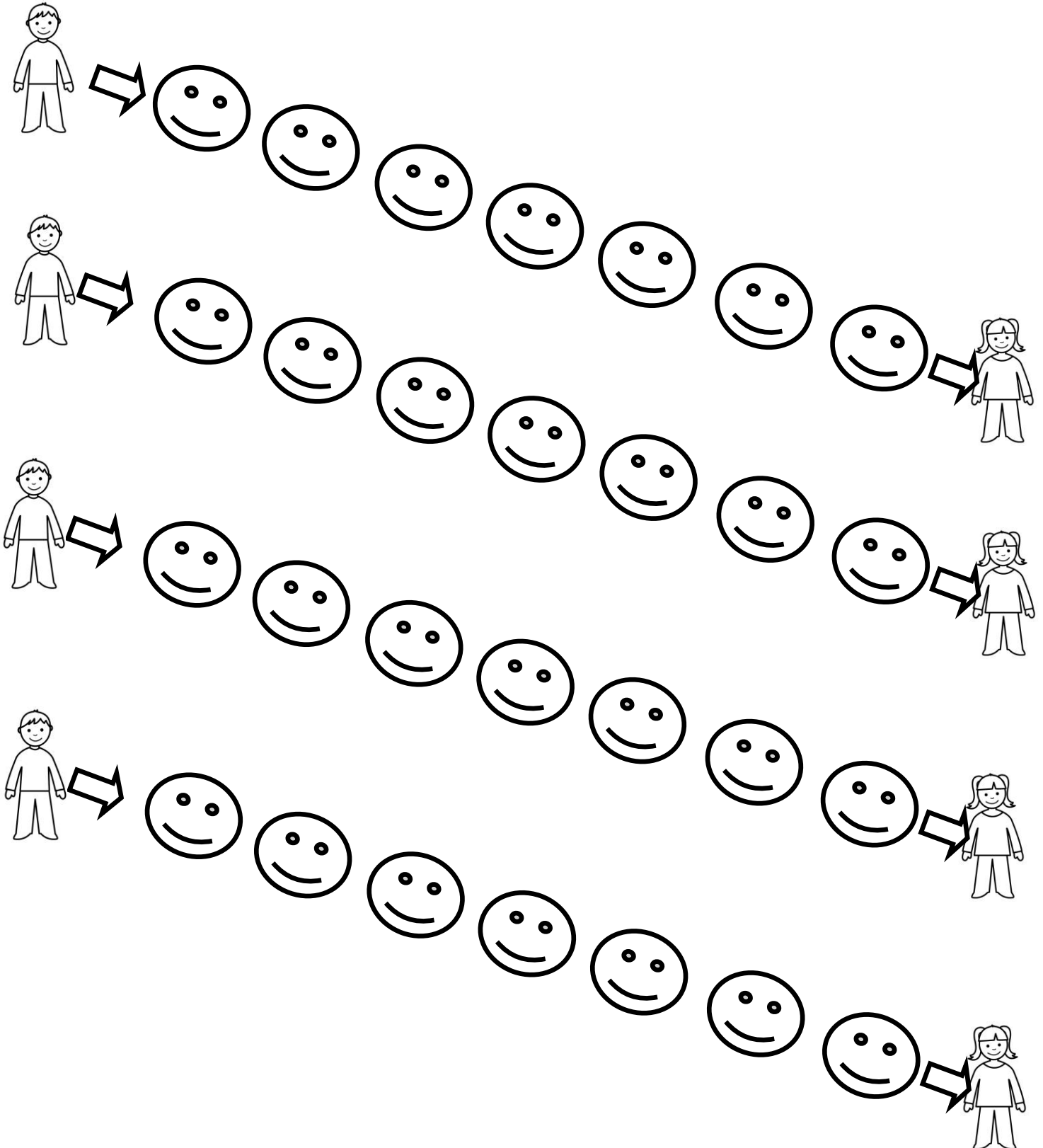

Actividades para mejorar motricidad fina

Sigue con tu lápiz las caras para unir al niño con su amiga

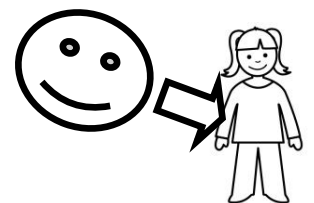
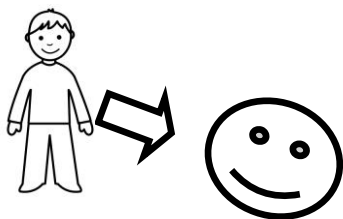
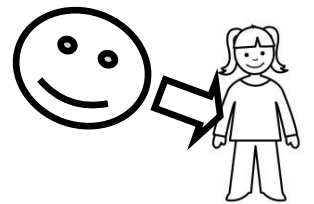
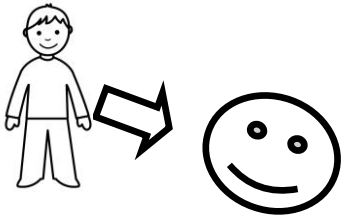
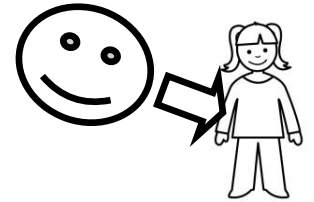
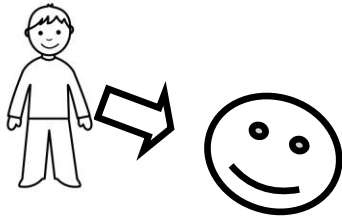
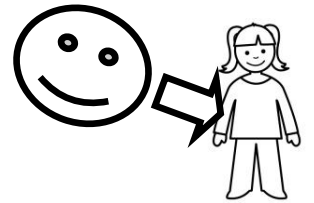
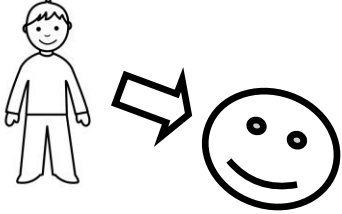

Actividades para mejorar motricidad fina

Sigue con tu lápiz los círculos para unir al niño con su pelota

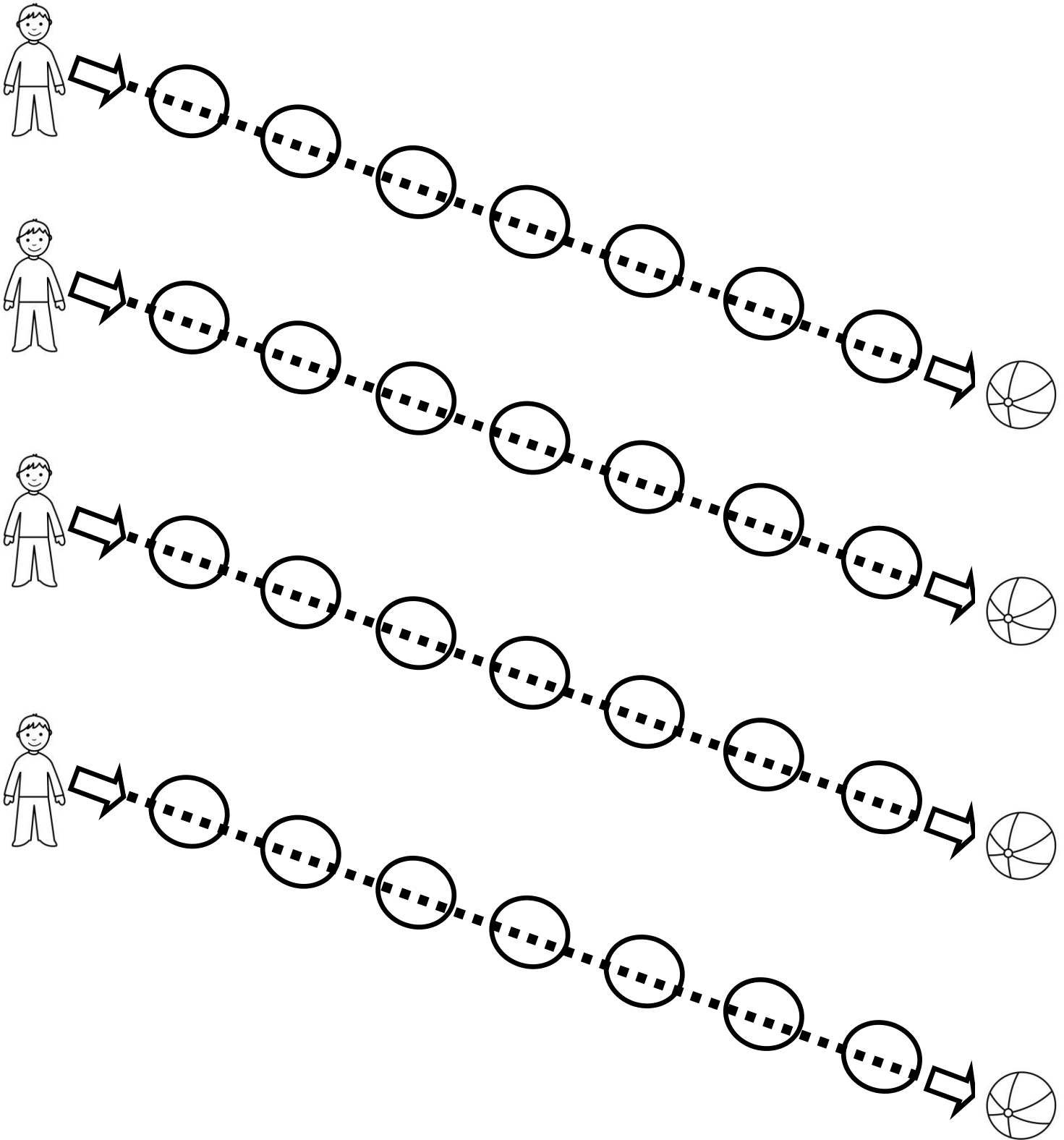

Actividades para mejorar motricidad fina

Sigue con tu lápiz los círculos para unir al niño con su pelota

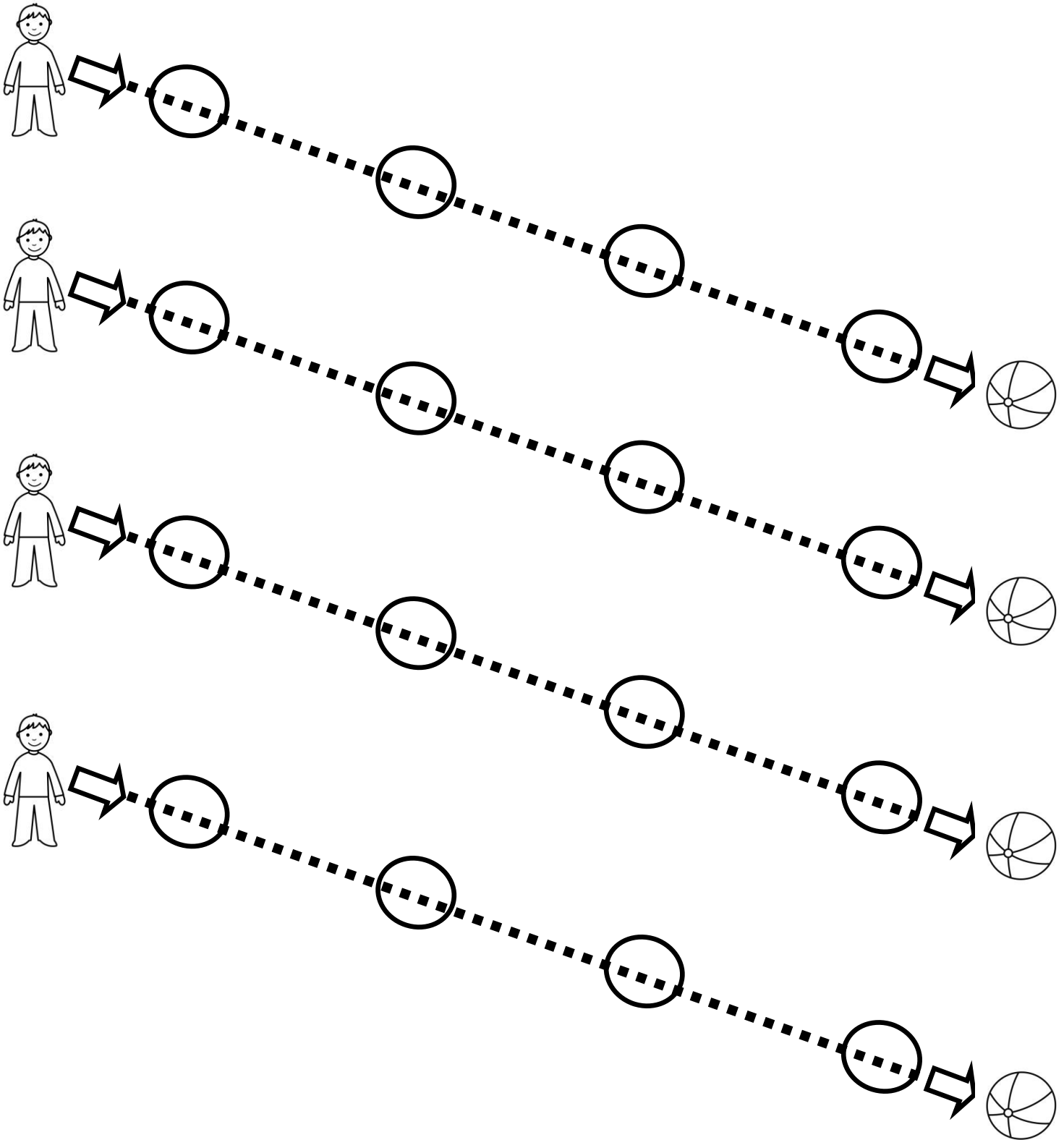

Actividades para mejorar motricidad fina

Sigue con tu lápiz los círculos para unir al niño con su pelota

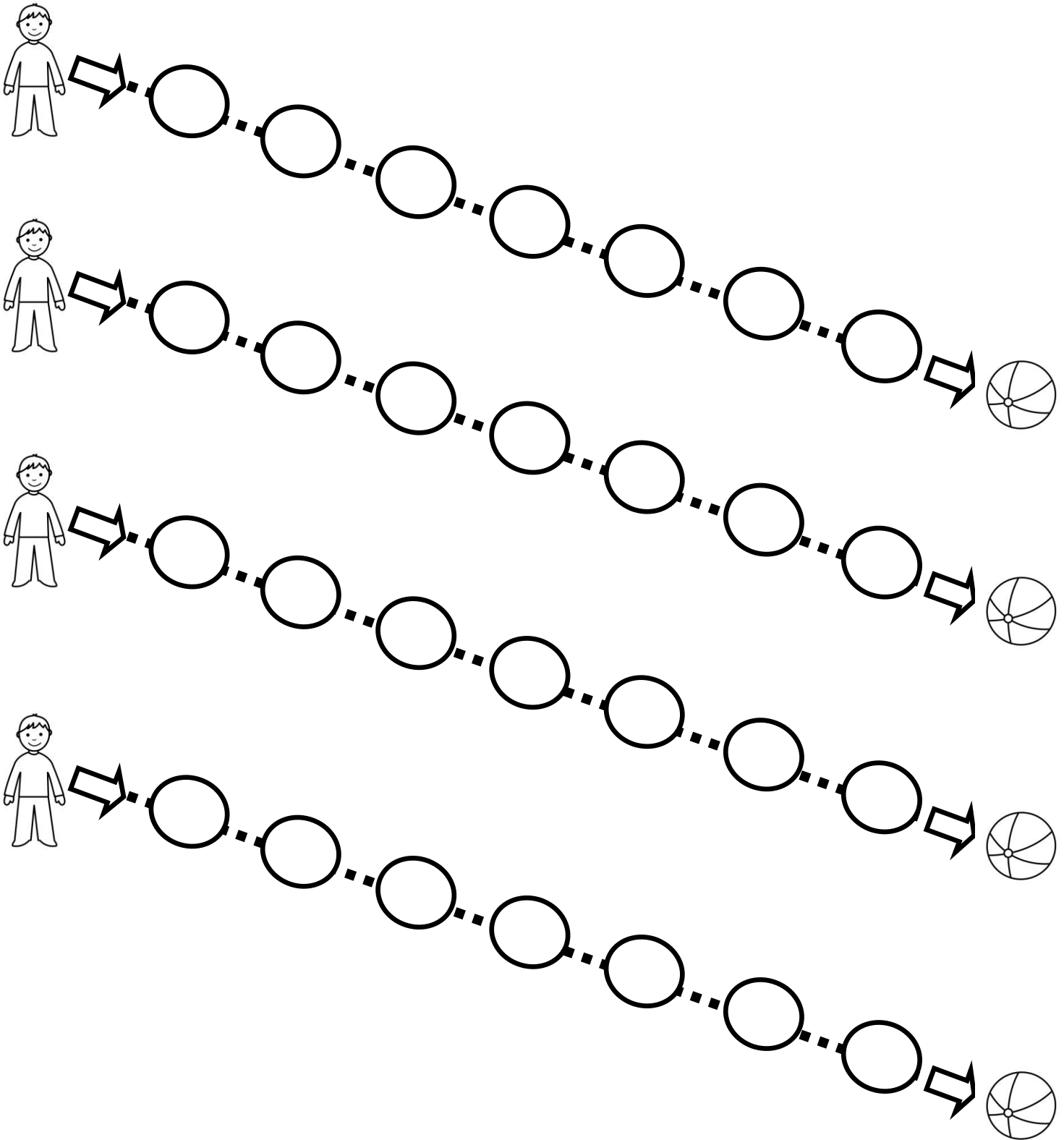

Actividades para mejorar motricidad fina

Sigue con tu lápiz los círculos para unir al niño con su pelota

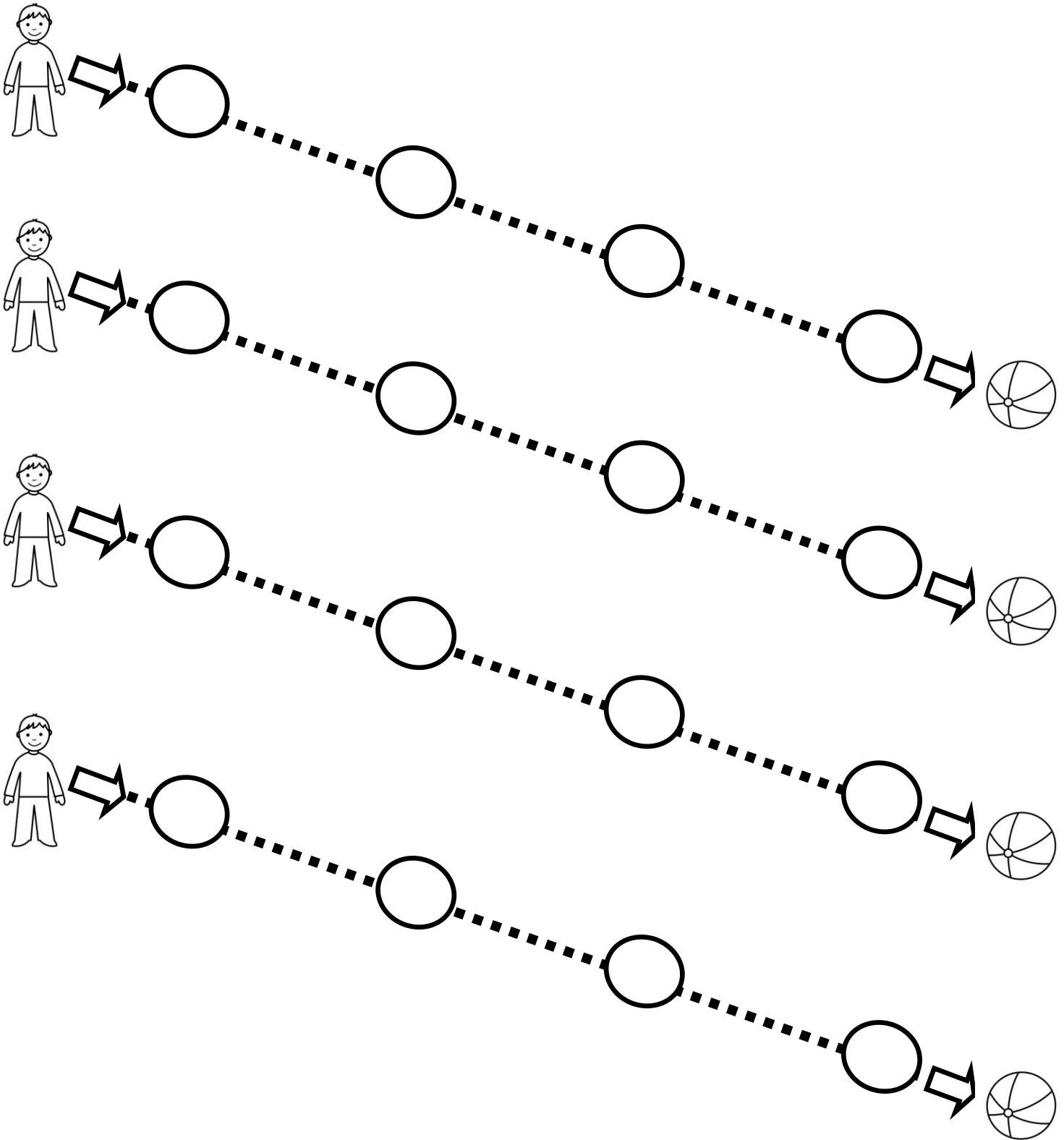

Actividades para mejorar motricidad fina

Sigue con tu lápiz los círculos para unir al niño con su pelota

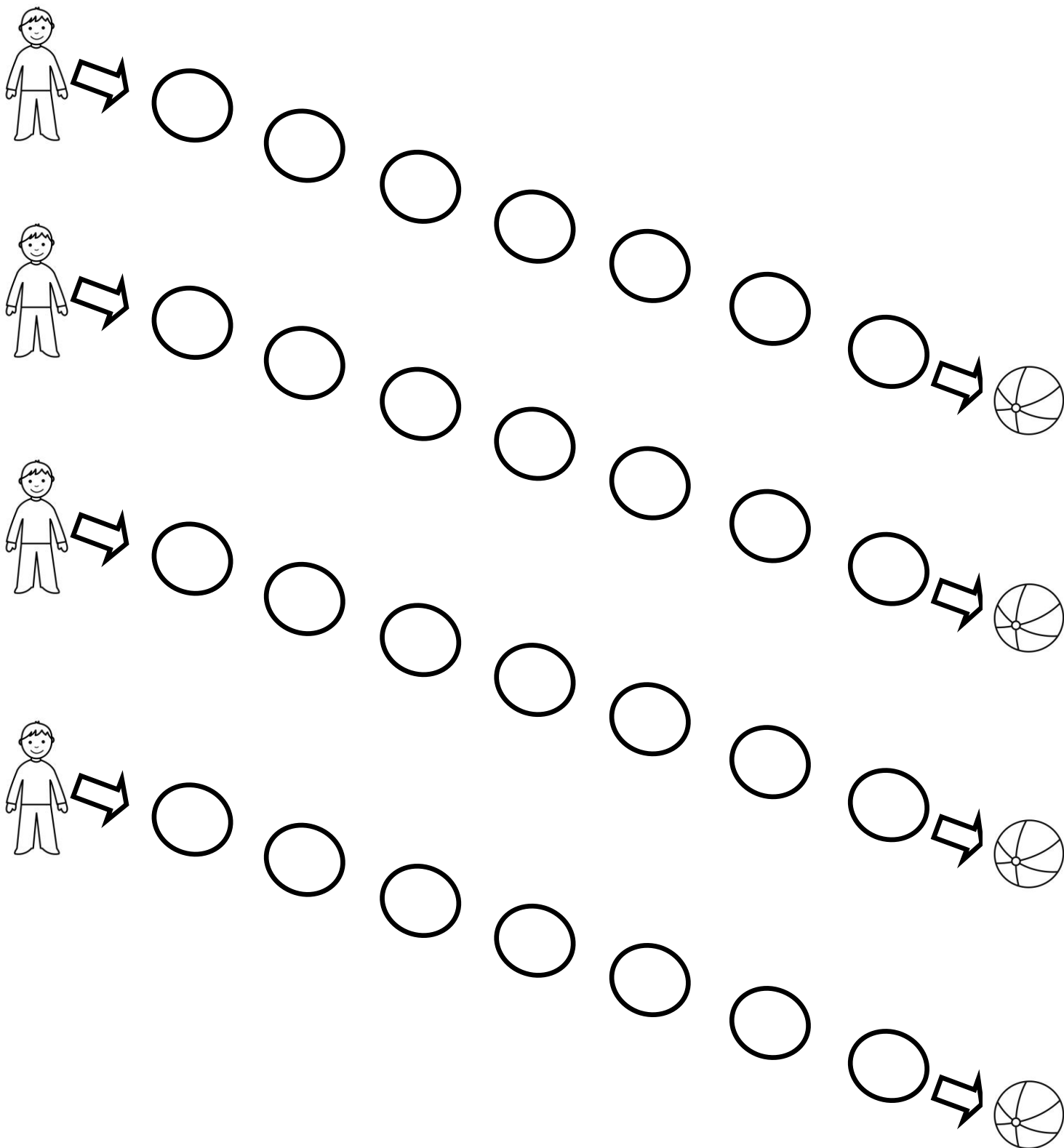

Actividades para mejorar motricidad fina

Sigue con tu lápiz los círculos para unir al niño con su pelota

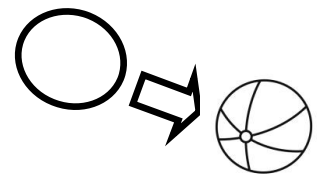
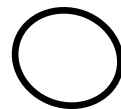
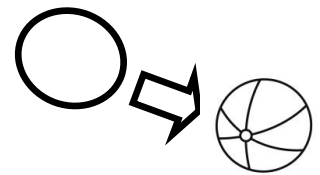
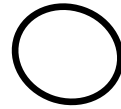
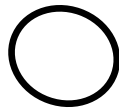
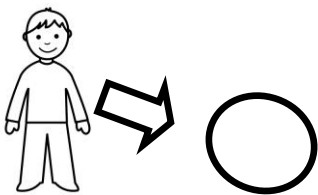
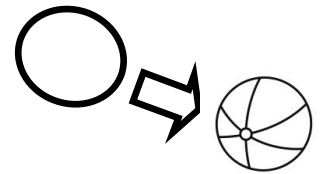
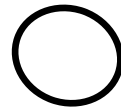
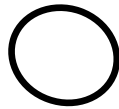
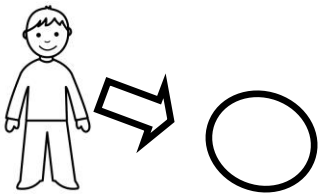
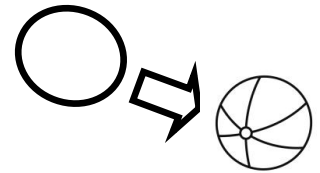
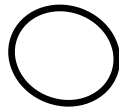
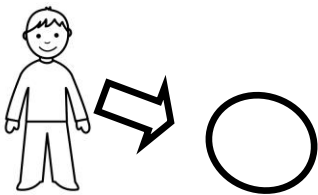
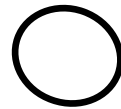
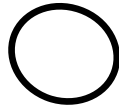
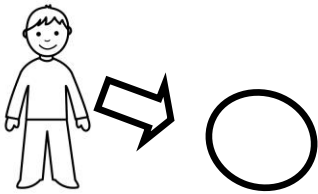

Actividades para mejorar motricidad fina

Sigue con tu lápiz las estrellitas para ir desde el sol a la tierra

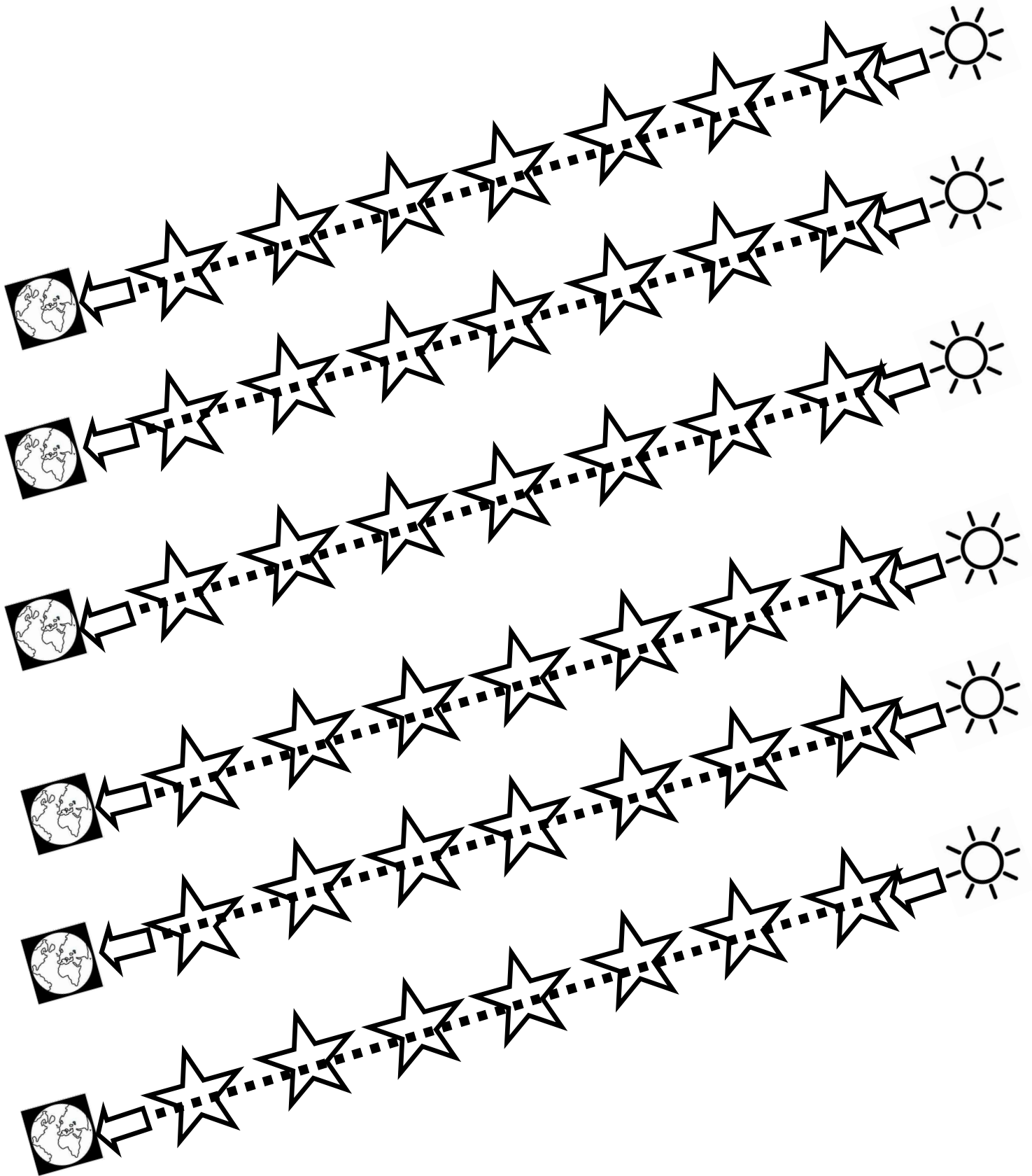

Actividades para mejorar motricidad fina

Sigue con tu lápiz las estrellitas para ir desde el sol a la tierra

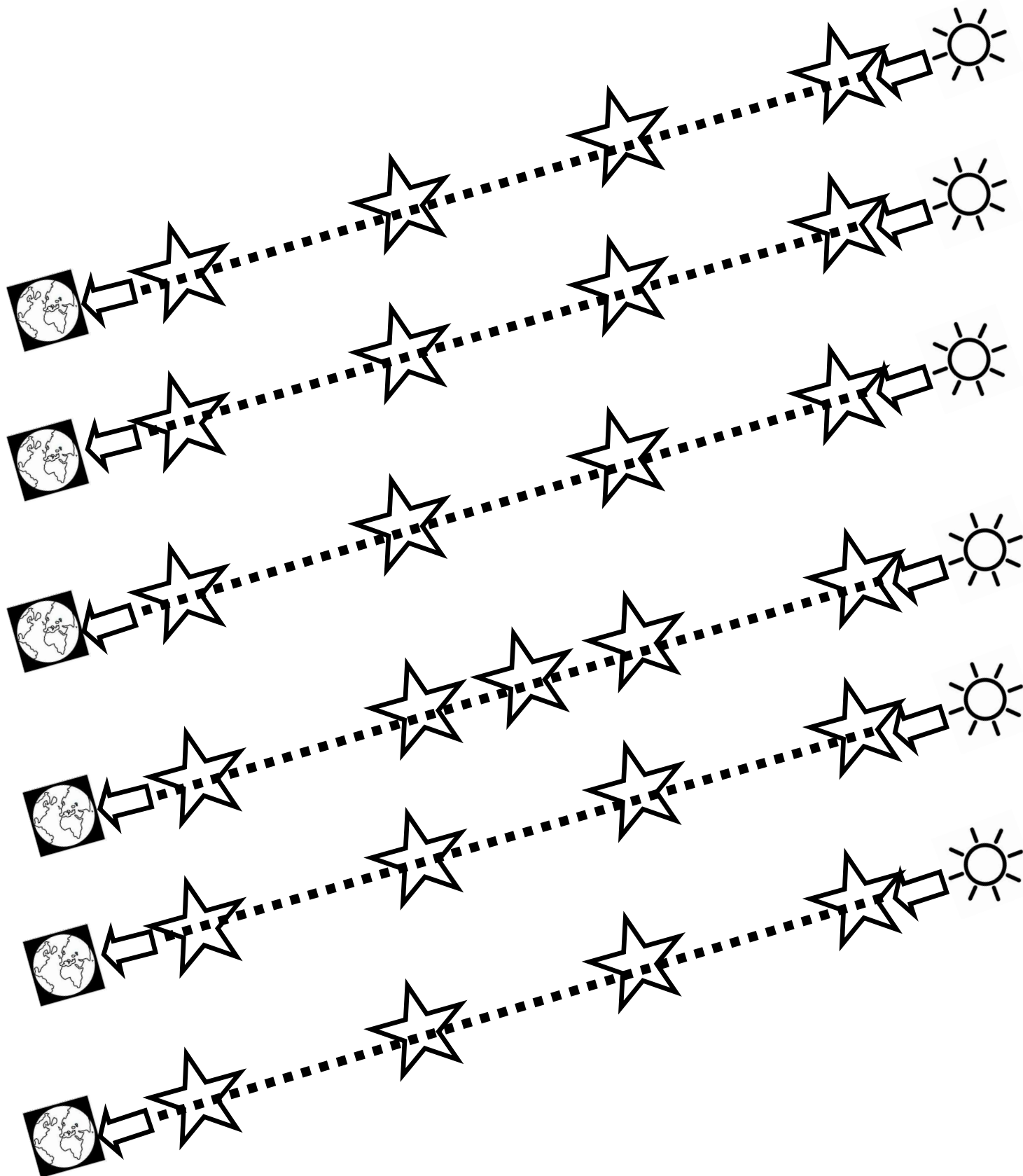

Actividades para mejorar motricidad fina

Sigue con tu lápiz las estrellitas para ir desde el sol a la tierra

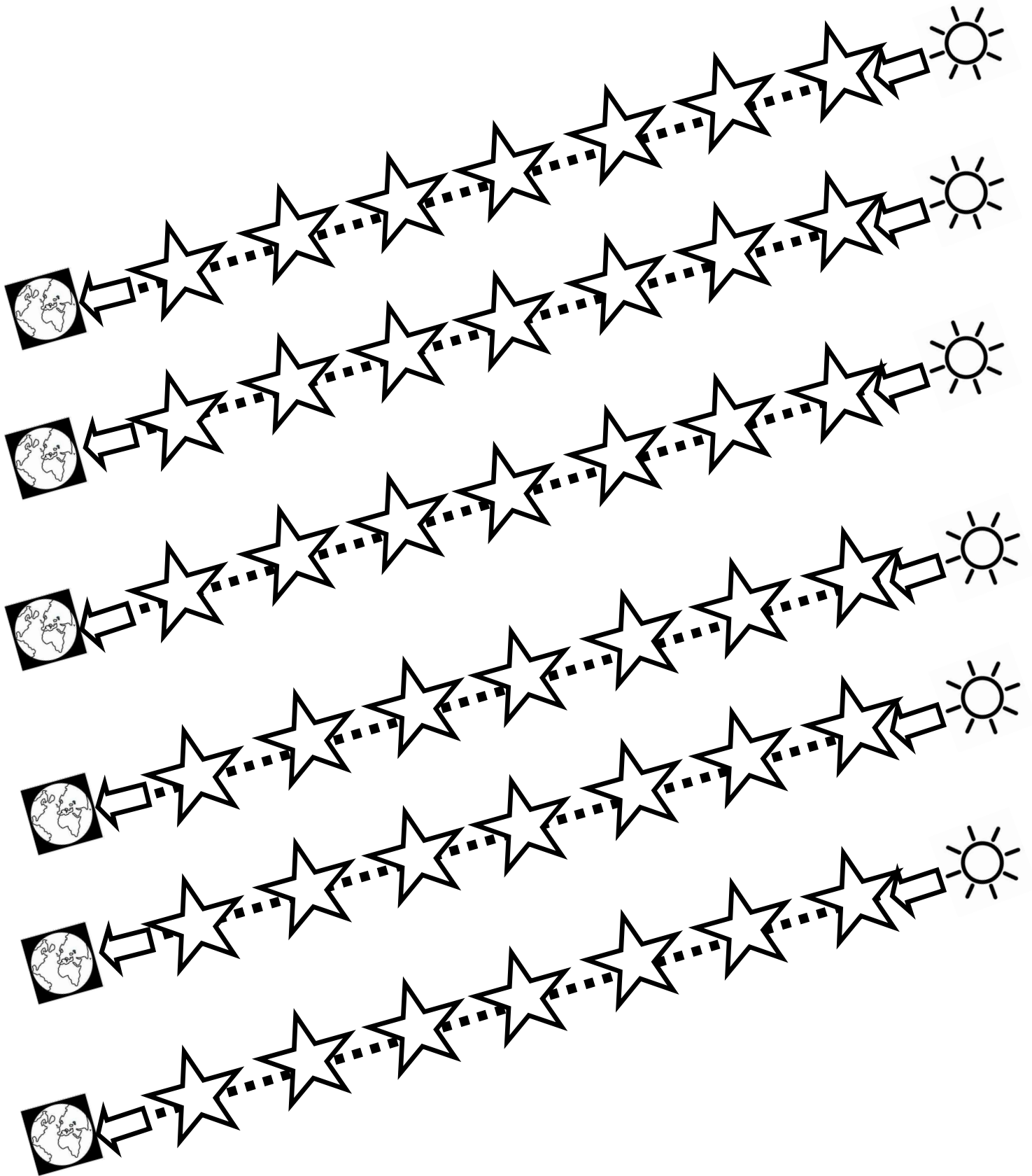

Actividades para mejorar motricidad fina

Sigue con tu lápiz las estrellitas para ir desde el sol a la tierra

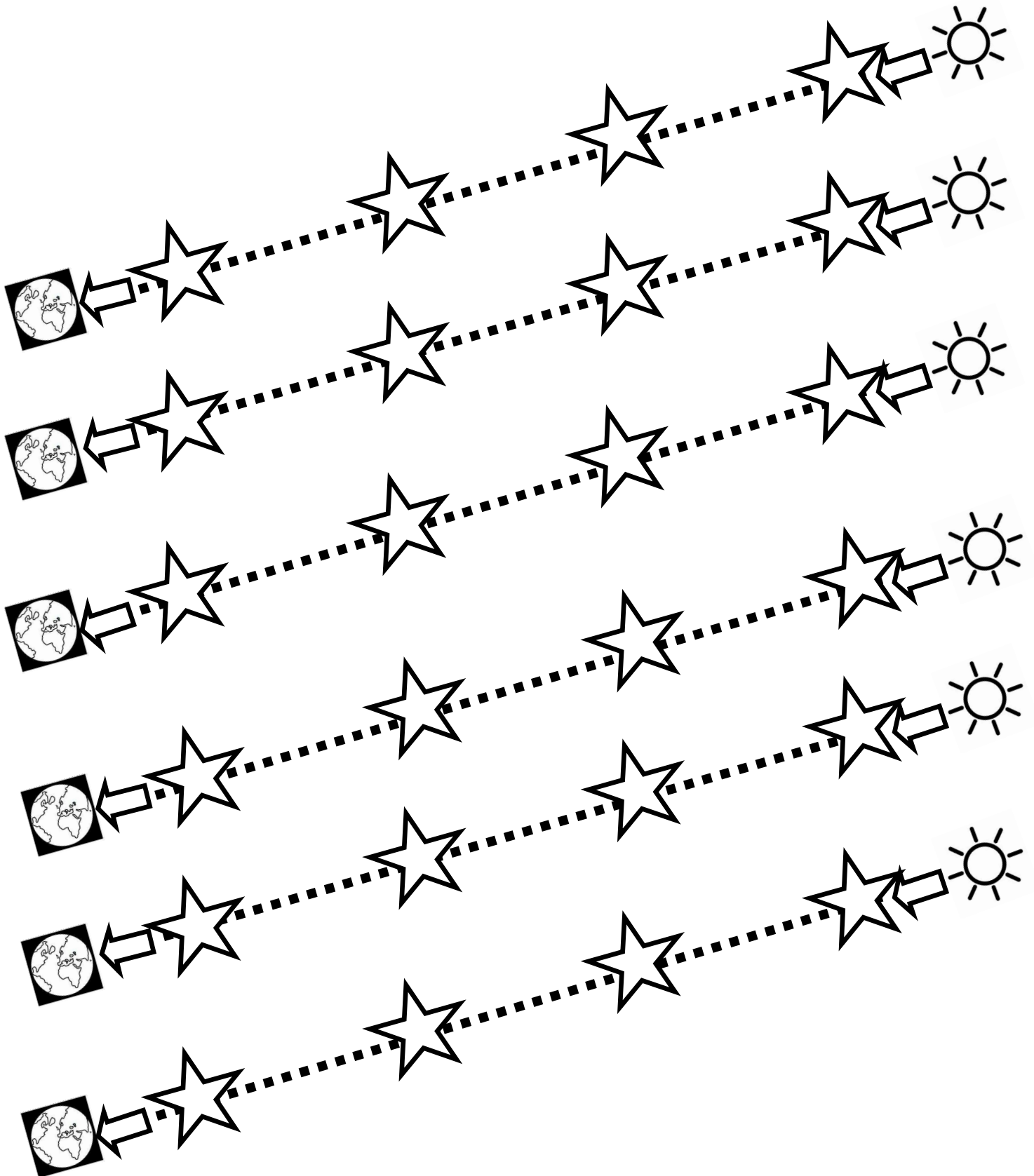

Actividades para mejorar motricidad fina

Sigue con tu lápiz las estrellitas para ir desde el sol a la tierra

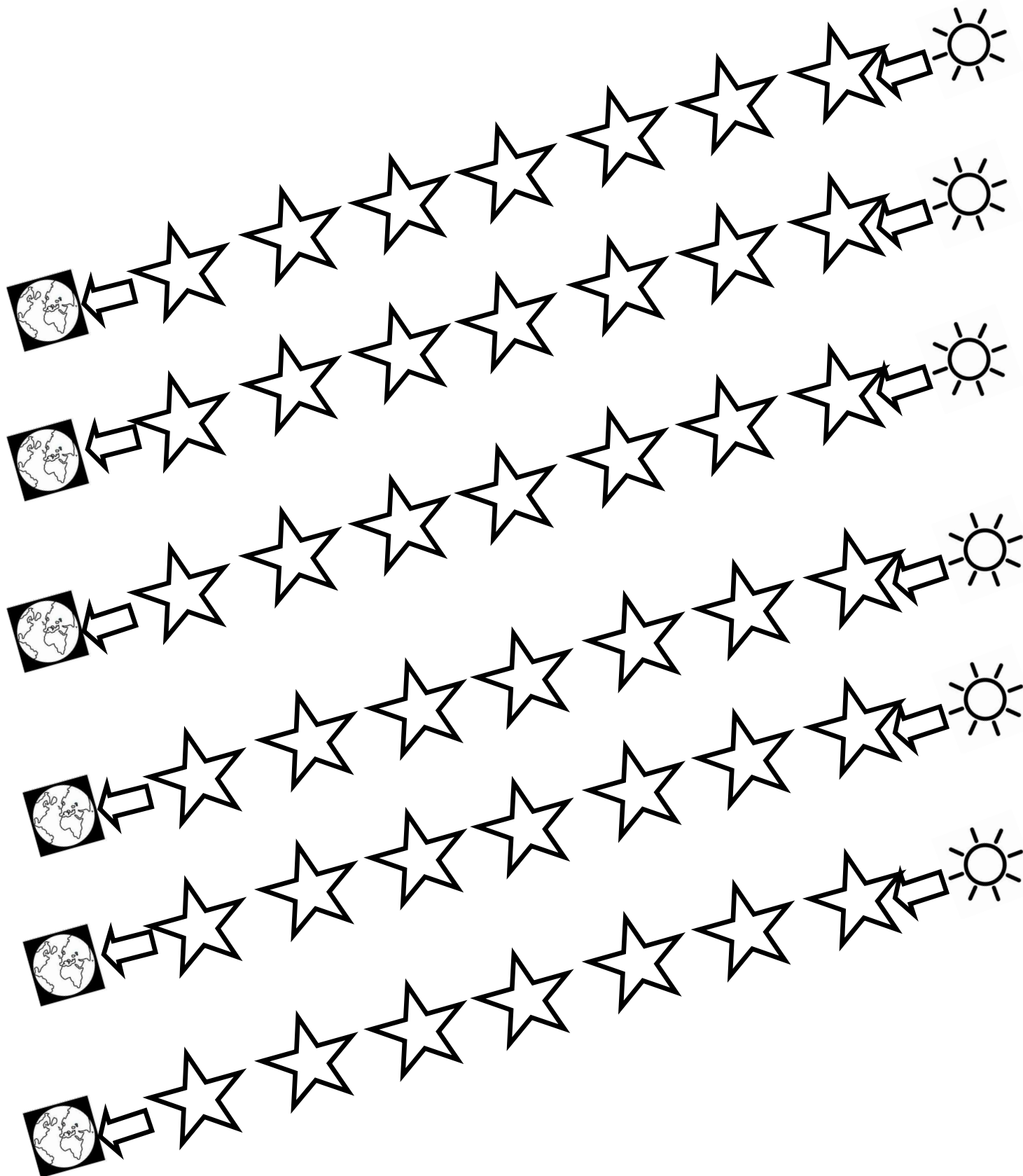

Actividades para mejorar motricidad fina

Sigue con tu lápiz las estrellitas para ir desde el sol a la tierra



Actividades para mejorar motricidad fina

Sigue con tu lápiz los corazones para unir a la mama y a su bebe

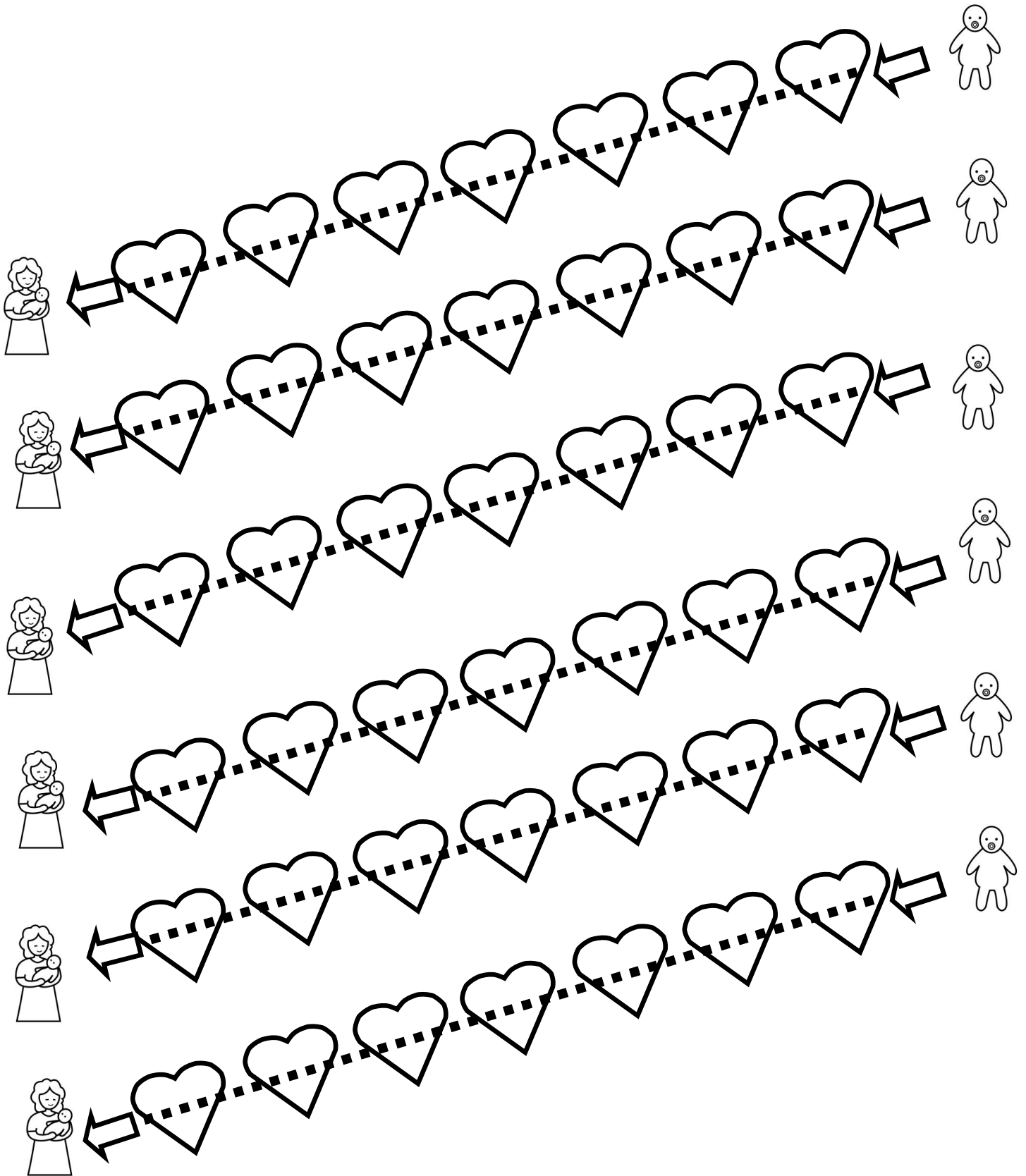

Actividades para mejorar motricidad fina

Sigue con tu lápiz los corazones para unir a la mama y a su bebe

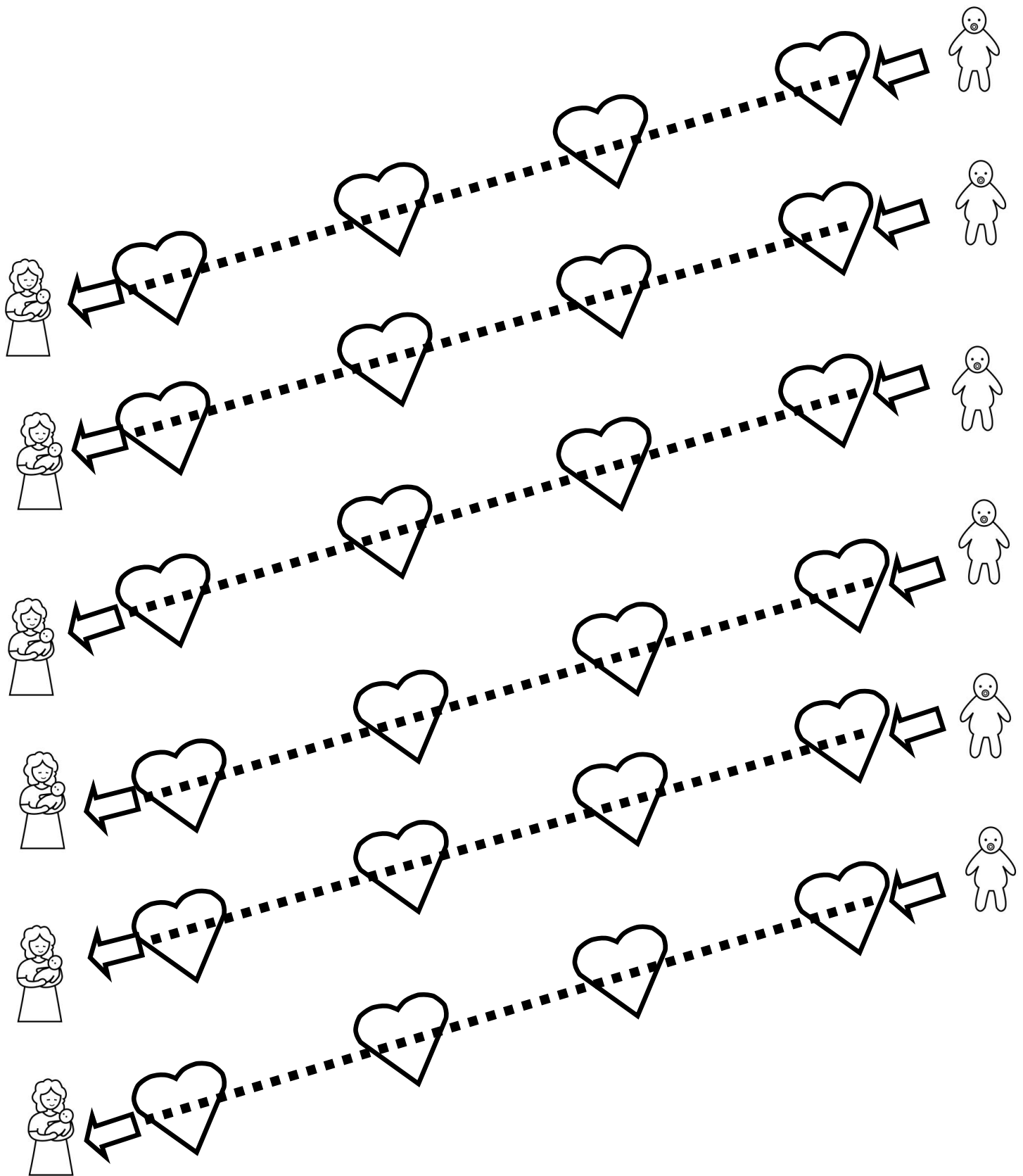

Actividades para mejorar motricidad fina

Sigue con tu lápiz los corazones para unir a la mama y a su bebe

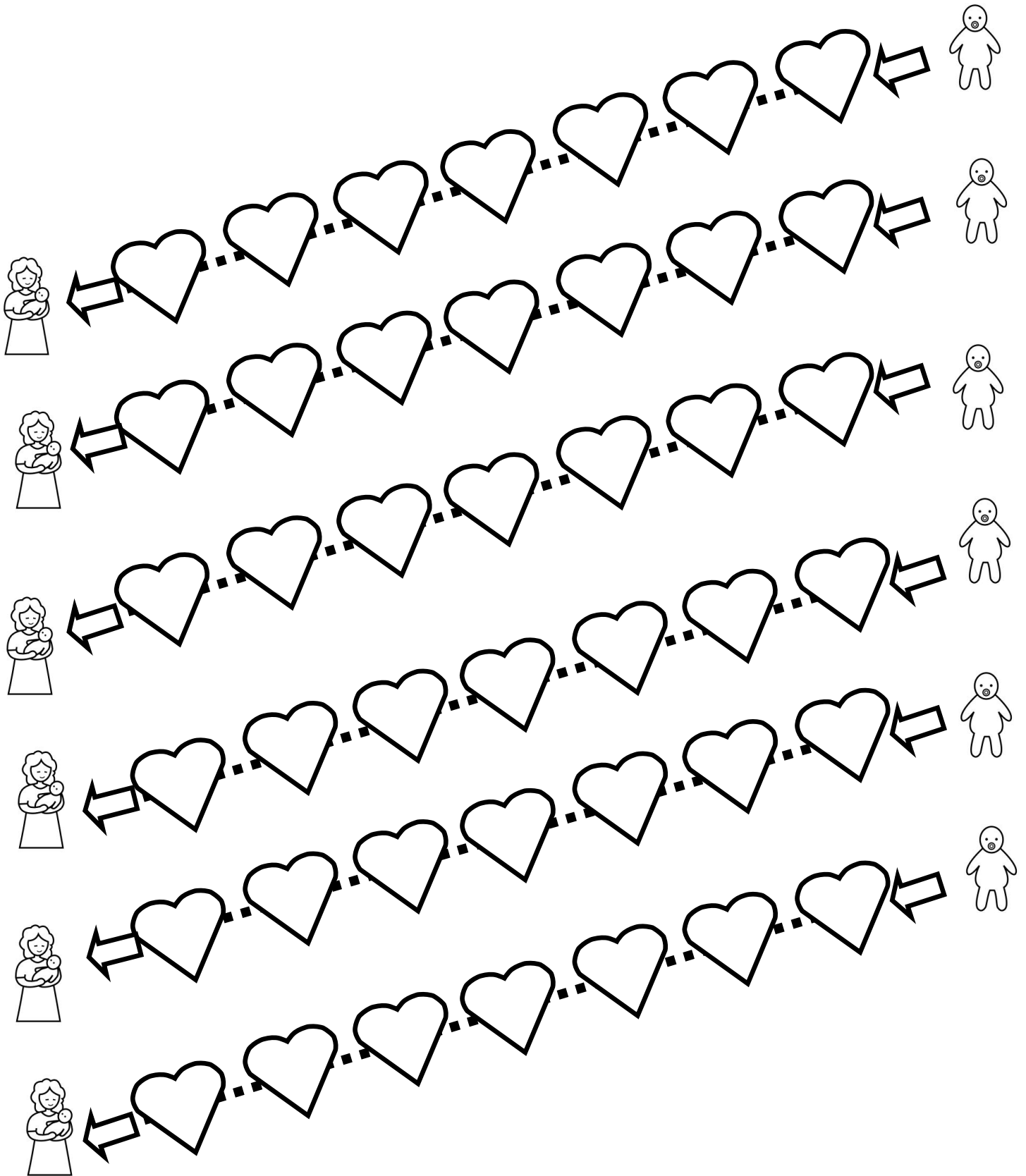

Actividades para mejorar motricidad fina

Sigue con tu lápiz los corazones para unir a la mama y a su bebe

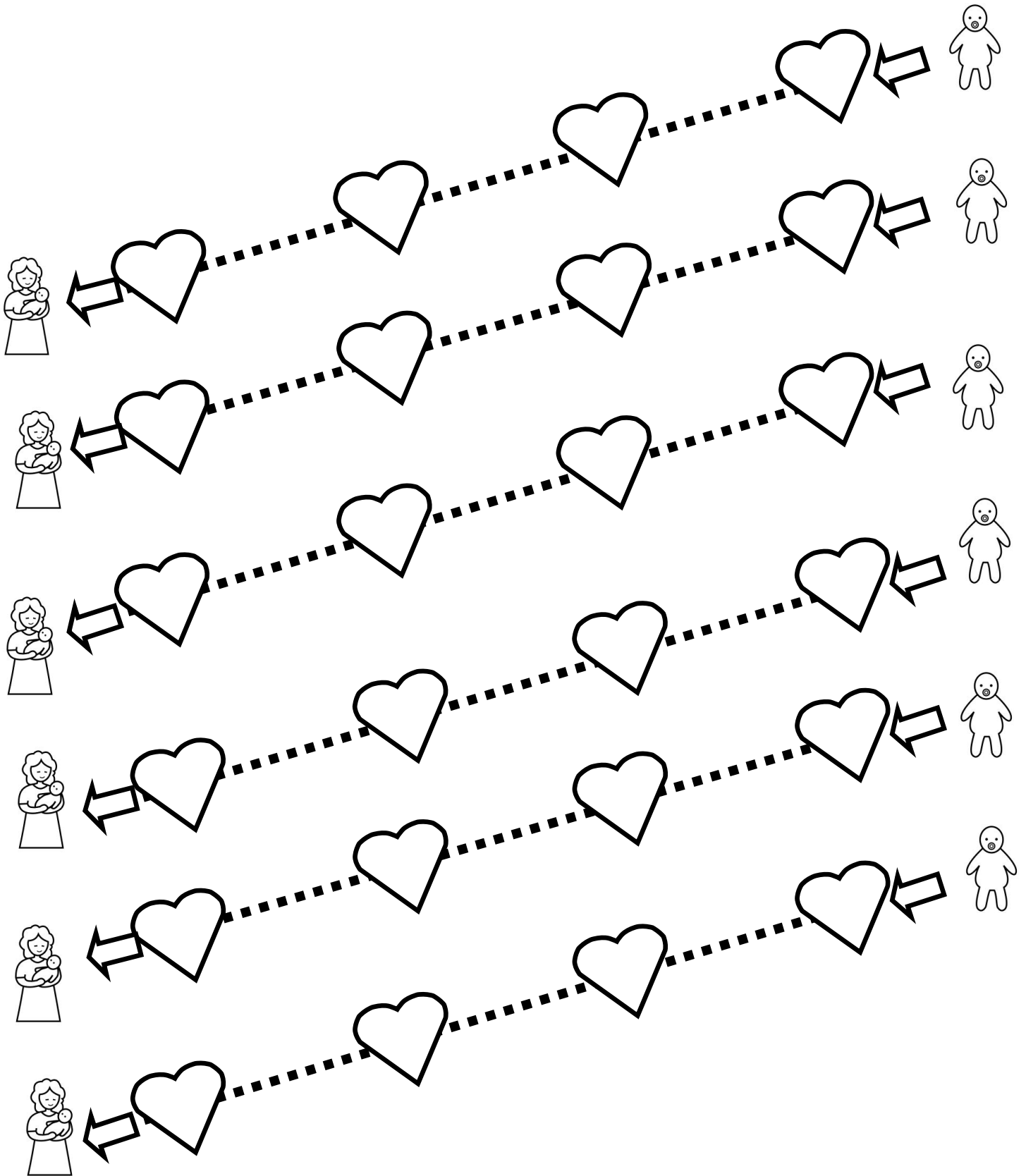

Actividades para mejorar motricidad fina

Sigue con tu lápiz los corazones para unir a la mama y a su bebe

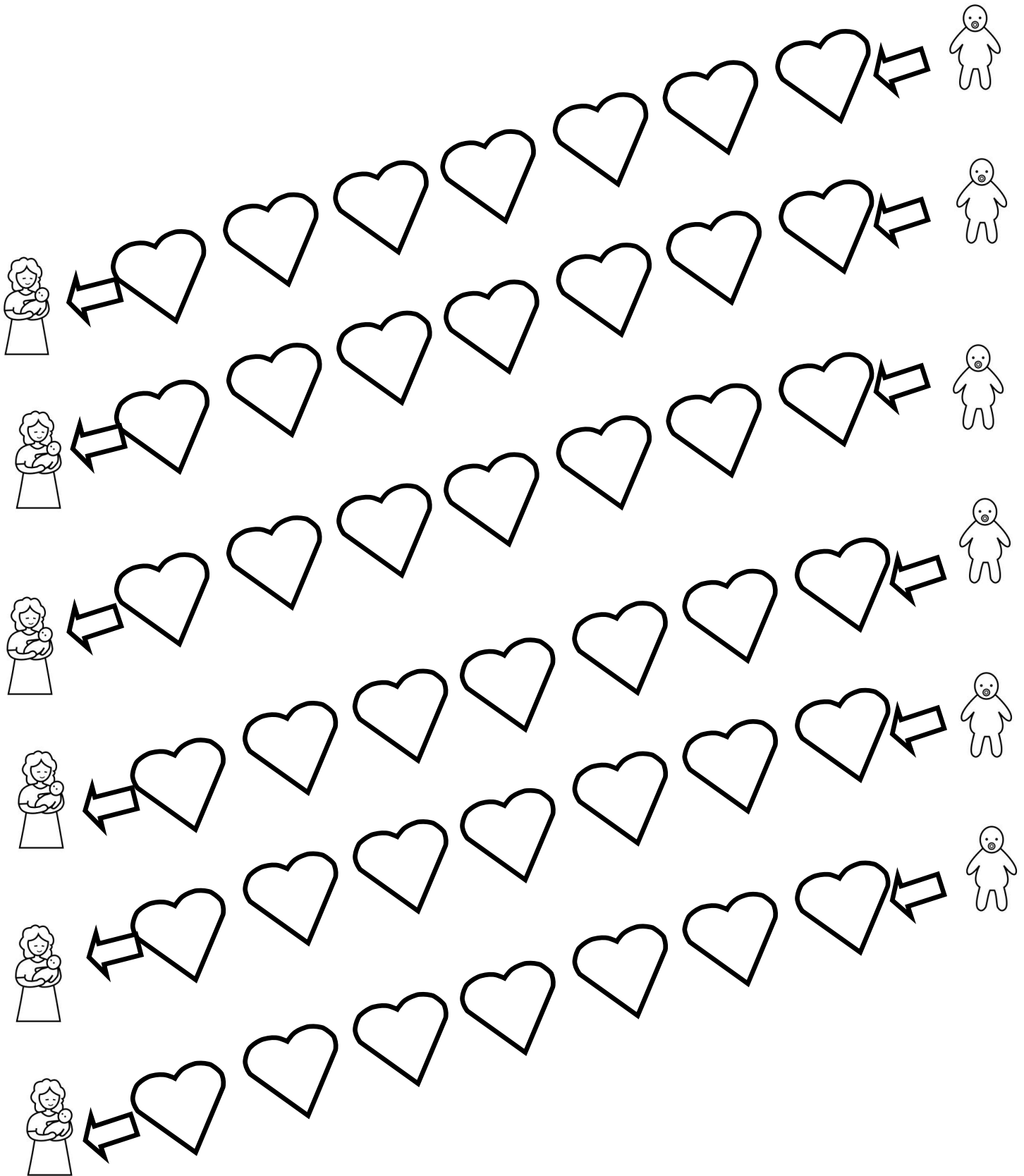

Actividades para mejorar motricidad fina

Sigue con tu lápiz los corazones para unir a la mama y a su bebe

The worksheet consists of six rows of tracing exercises. Each row starts with a mother holding a baby on the left. The first column contains a heart with an arrow pointing left towards the mother. The second column contains a heart with an arrow pointing right towards the baby. The third column contains a heart with an arrow pointing left towards the mother. The fourth column contains a heart with an arrow pointing right towards the baby. The fifth column contains a heart with an arrow pointing left towards the mother. The sixth column contains a heart with an arrow pointing right towards the baby. The final column contains a heart with an arrow pointing left towards the mother. The final column contains a baby icon.

Actividades para mejorar motricidad fina

Sigue con tu lápiz las caras para unir al niño con su amiga

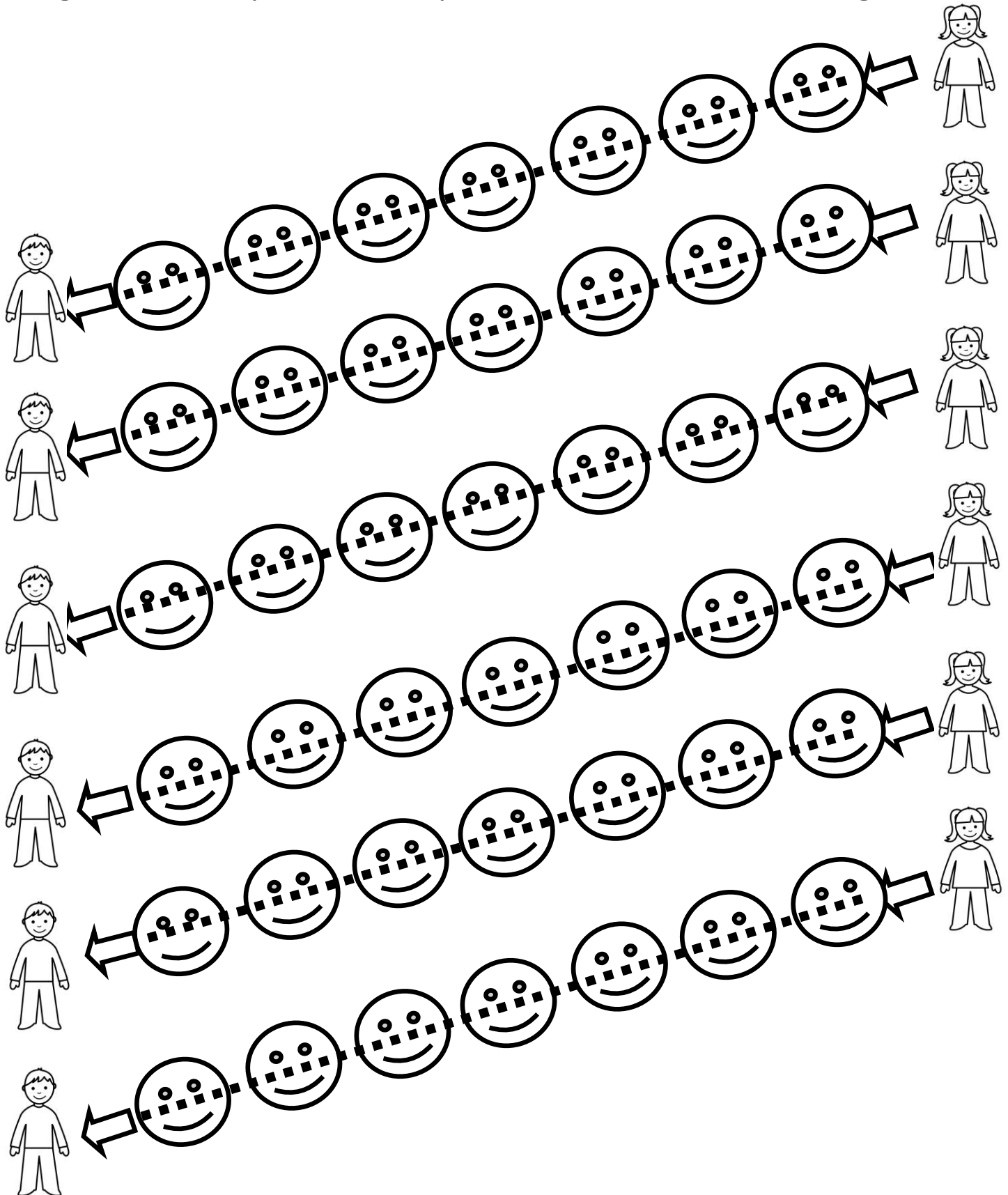

Actividades para mejorar motricidad fina

Sigue con tu lápiz las caras para unir al niño con su amiga

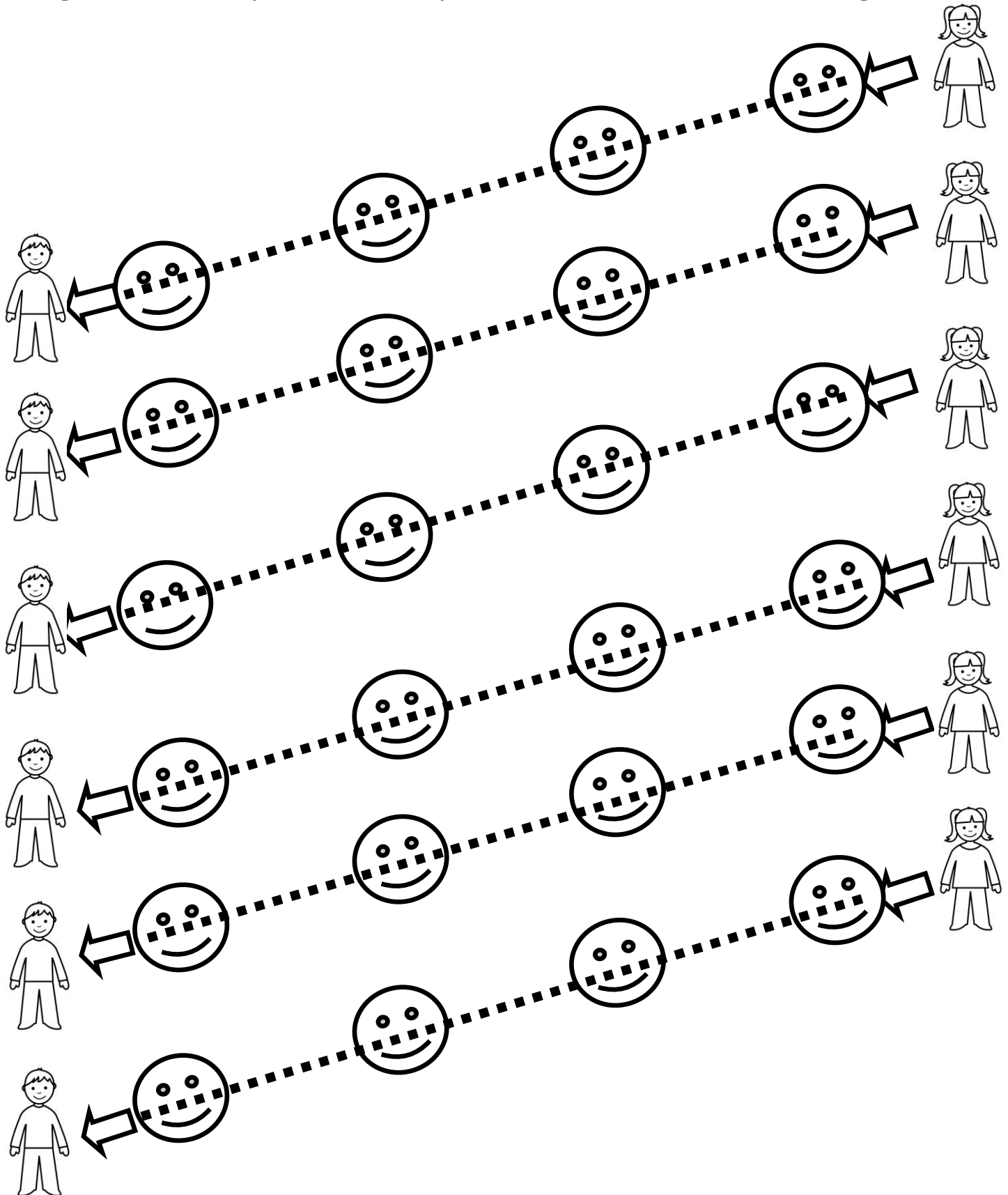

Actividades para mejorar motricidad fina

Sigue con tu lápiz las caras para unir al niño con su amiga

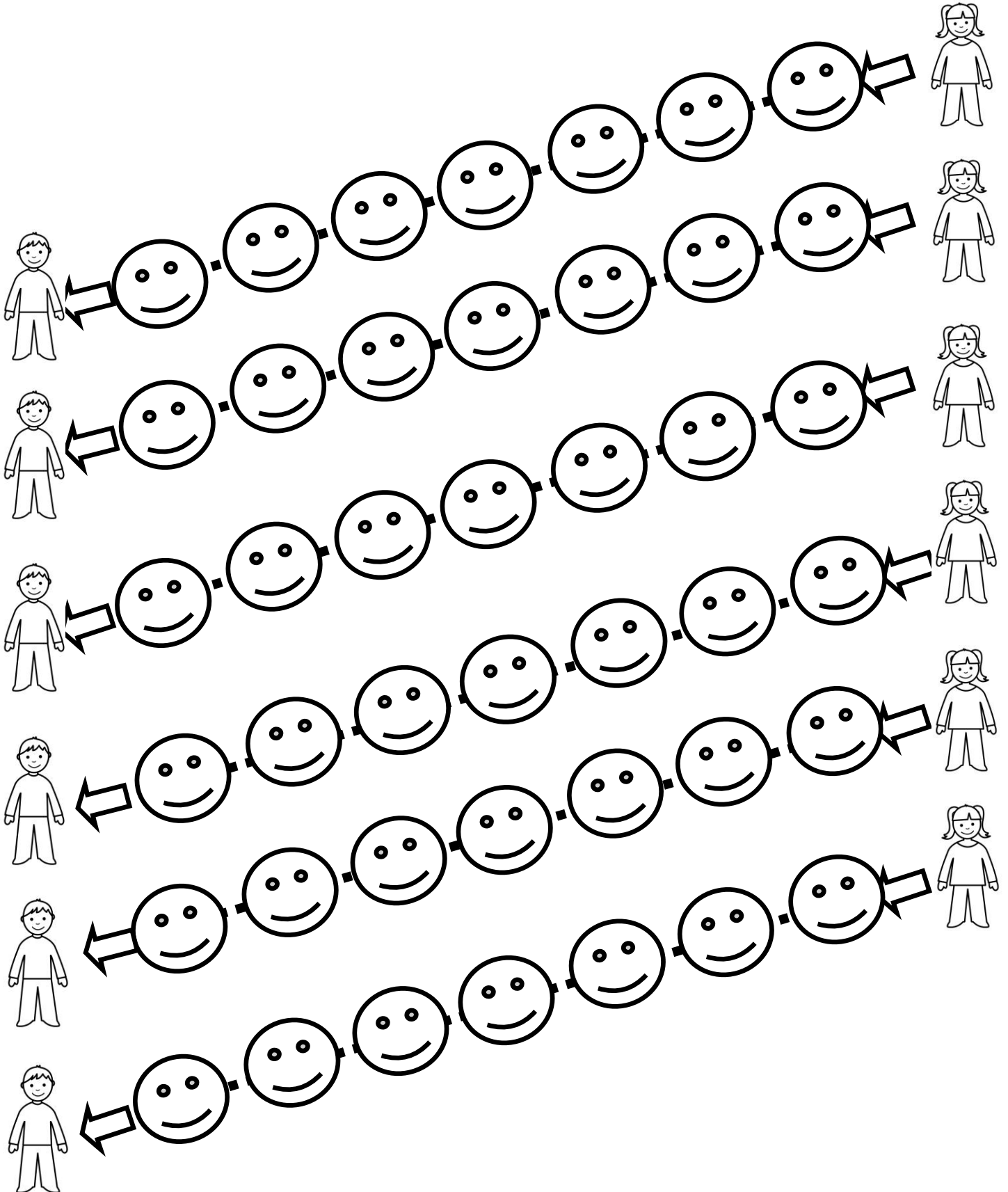

Actividades para mejorar motricidad fina

Sigue con tu lápiz las caras para unir al niño con su amiga

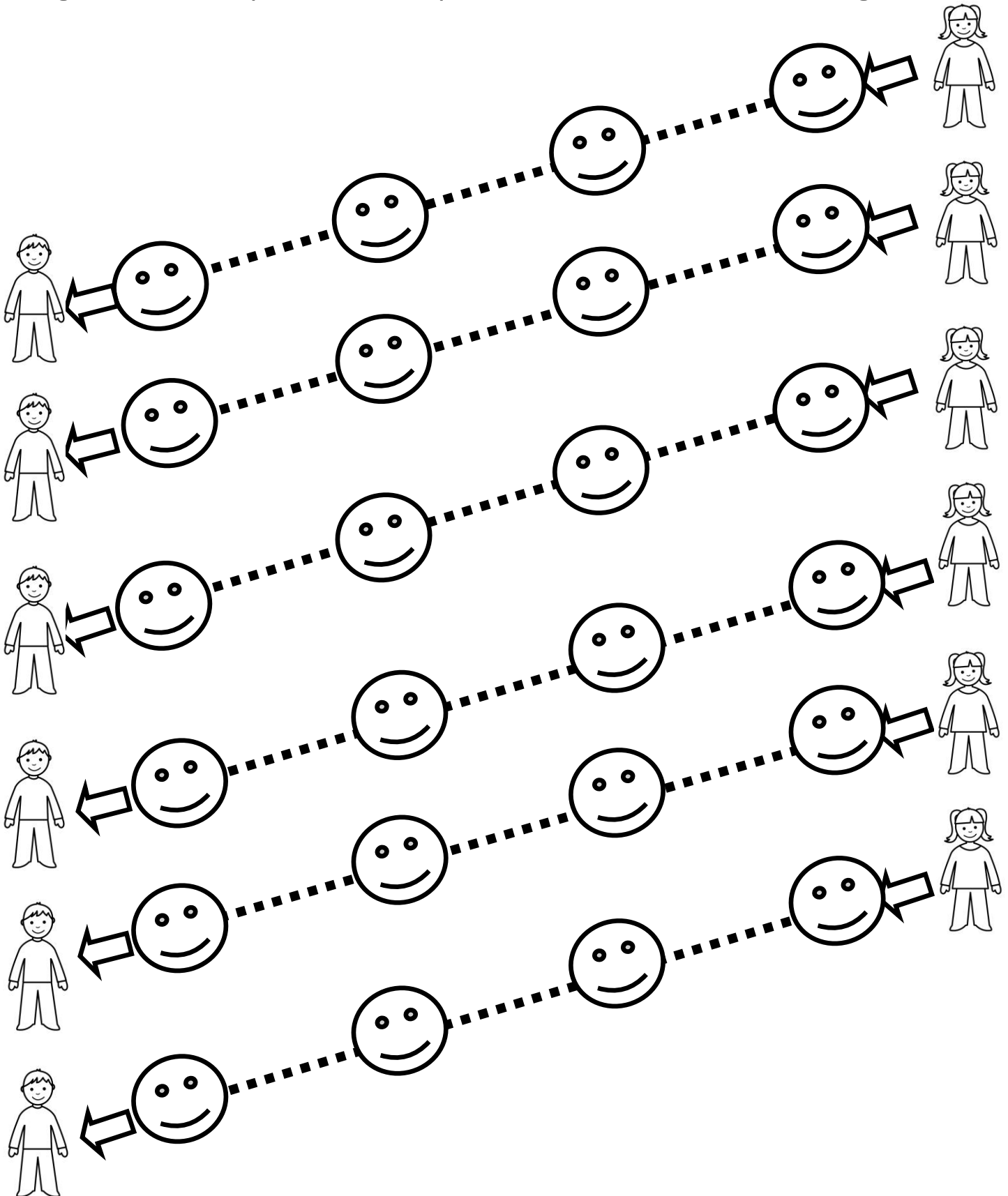

Actividades para mejorar motricidad fina

Sigue con tu lápiz las caras para unir al niño con su amiga

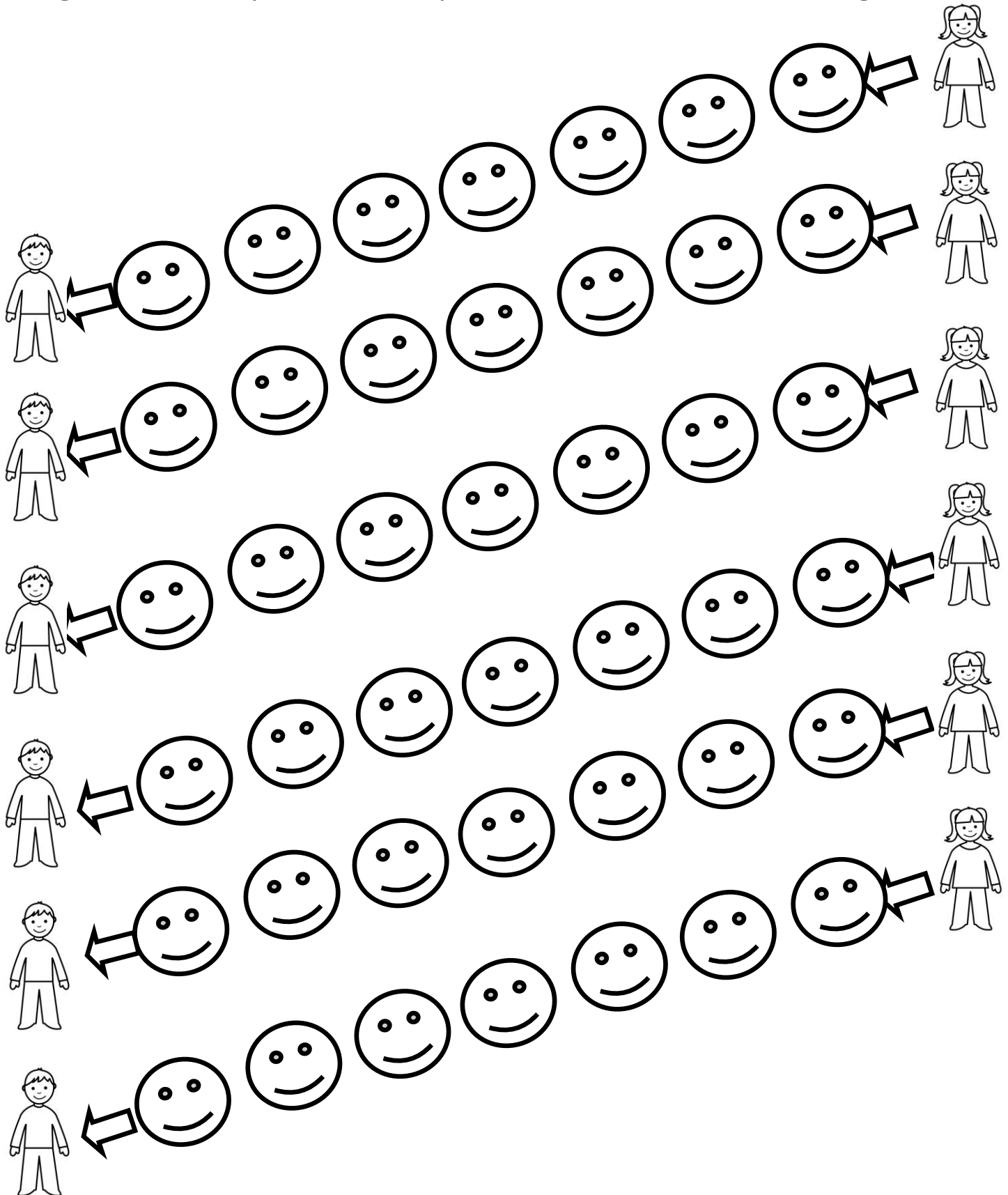

Actividades para mejorar motricidad fina

Sigue con tu lápiz las caras para unir al niño con su amiga

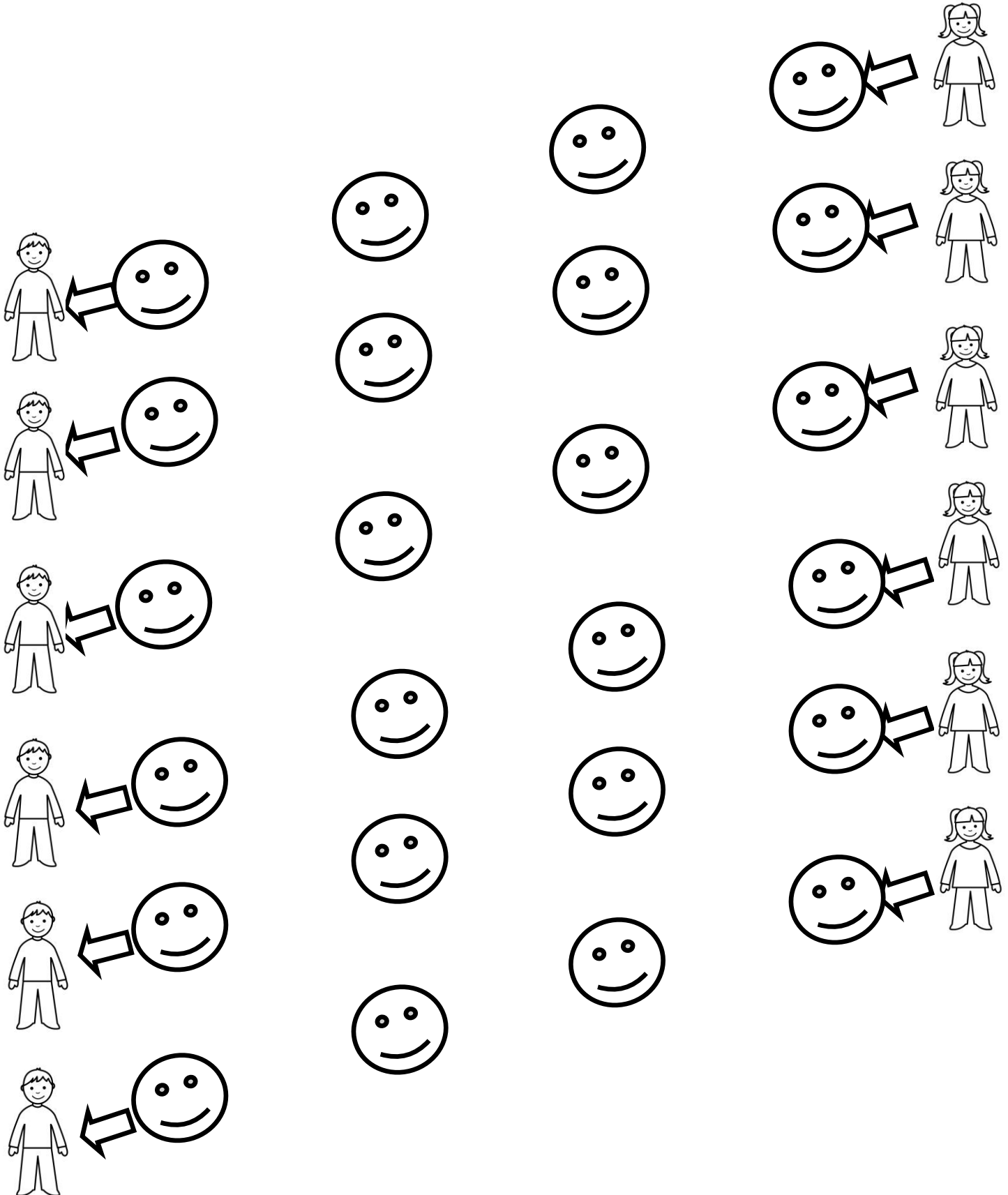

Actividades para mejorar motricidad fina

Sigue con tu lápiz los círculos para unir al niño con su pelota

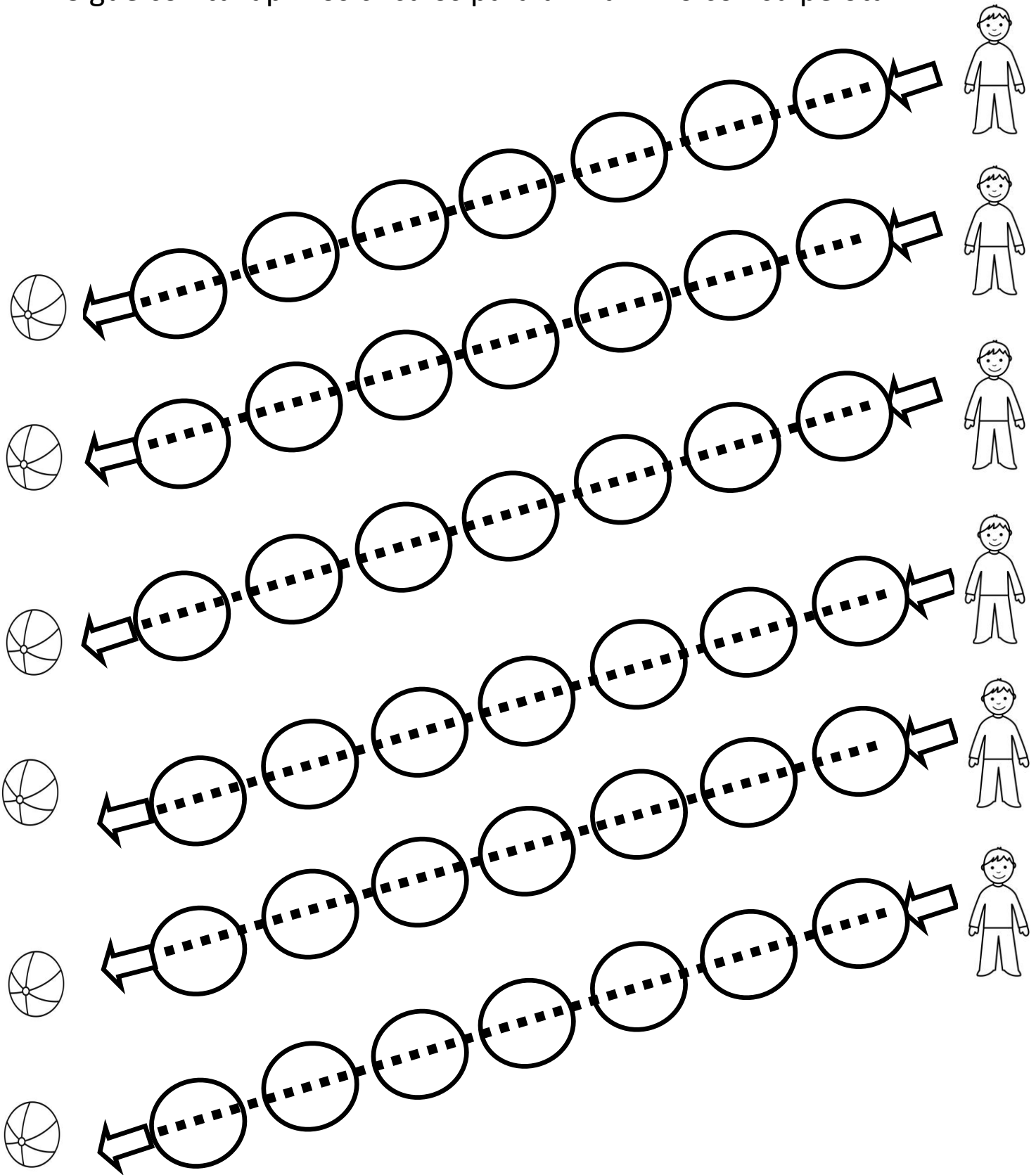

Actividades para mejorar motricidad fina

Sigue con tu lápiz los círculos para unir al niño con su pelota

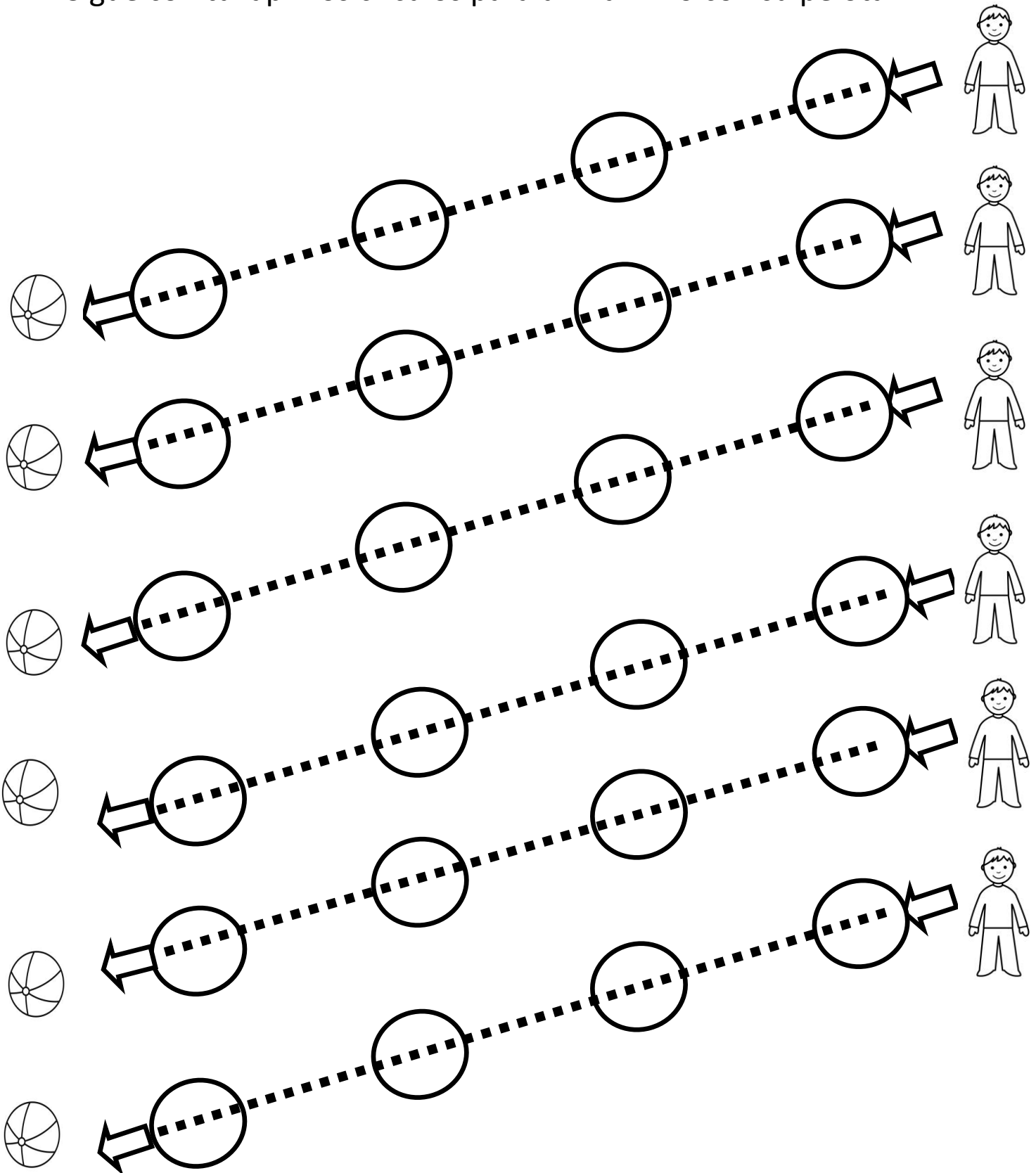

Actividades para mejorar motricidad fina

Sigue con tu lápiz los círculos para unir al niño con su pelota

Actividades para mejorar motricidad fina

Sigue con tu lápiz los círculos para unir al niño con su pelota

Actividades para mejorar motricidad fina

Sigue con tu lápiz los círculos para unir al niño con su pelota

The activity is a tracing exercise. It features seven horizontal rows. Each row begins with a ball on the left and an arrow pointing to the right. This is followed by a sequence of circles that form a path leading to a boy on the right. The path of circles is designed to be traced with a pencil. The boy is a simple line drawing of a child standing.

Actividades para mejorar motricidad fina

Sigue con tu lápiz los círculos para unir al niño con su pelota

The worksheet consists of four vertical columns of shapes. The first column has seven rows, each starting with a ball icon, followed by an arrow pointing left towards a circle. The second column has seven empty circles. The third column has seven empty circles. The fourth column has seven circles, each with an arrow pointing left towards it. To the right of each circle in the fourth column is a simple line drawing of a boy. The task is to connect the circles in the first column to the circles in the fourth column using a line, and then connect the circles in the second column to the circles in the third column.

Actividades para mejorar motricidad fina

Sigue con tu lápiz los cuadrados para unir a la niña con su casa

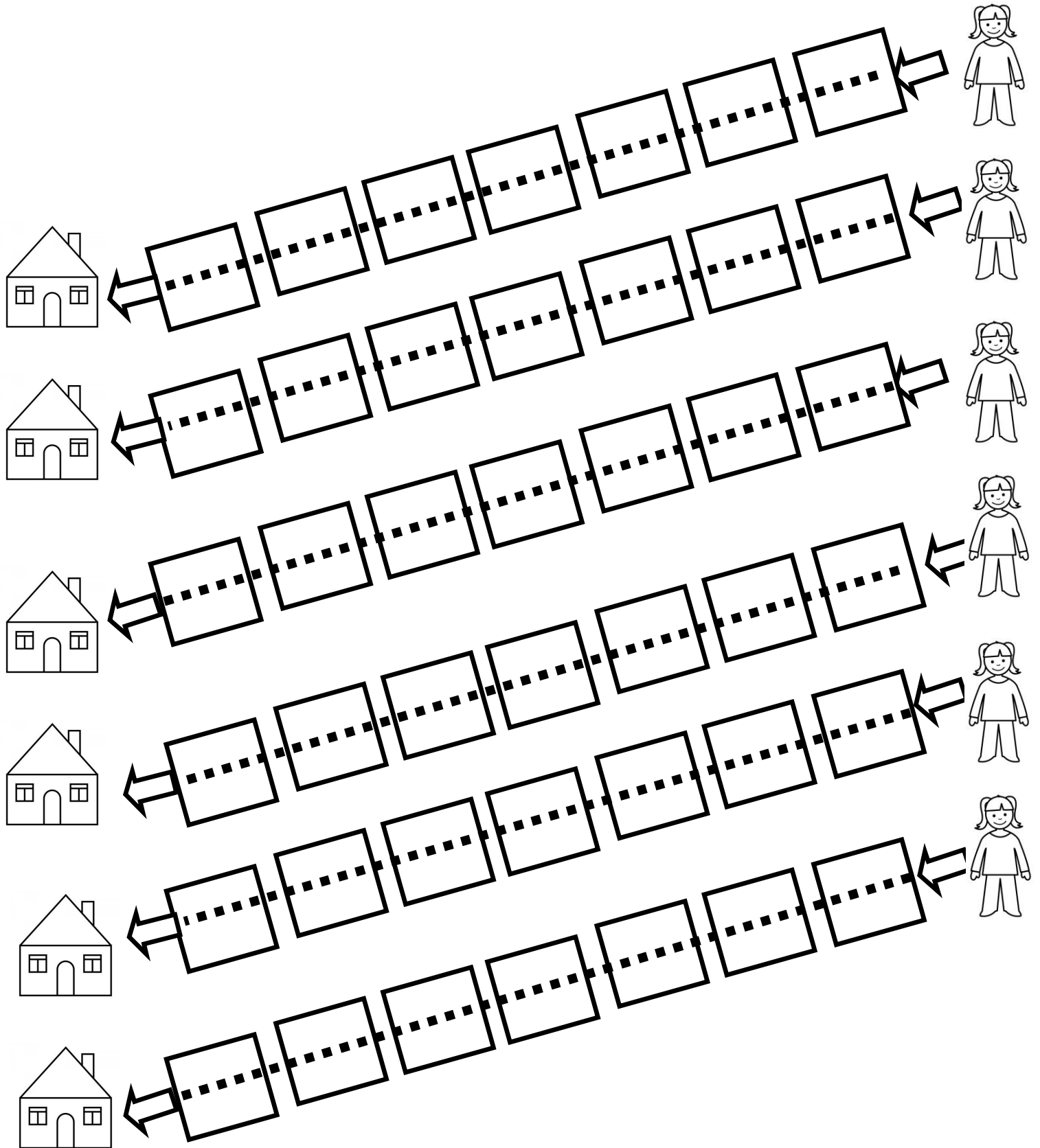

Actividades para mejorar motricidad fina

Sigue con tu lápiz los cuadrados para unir a la niña con su casa

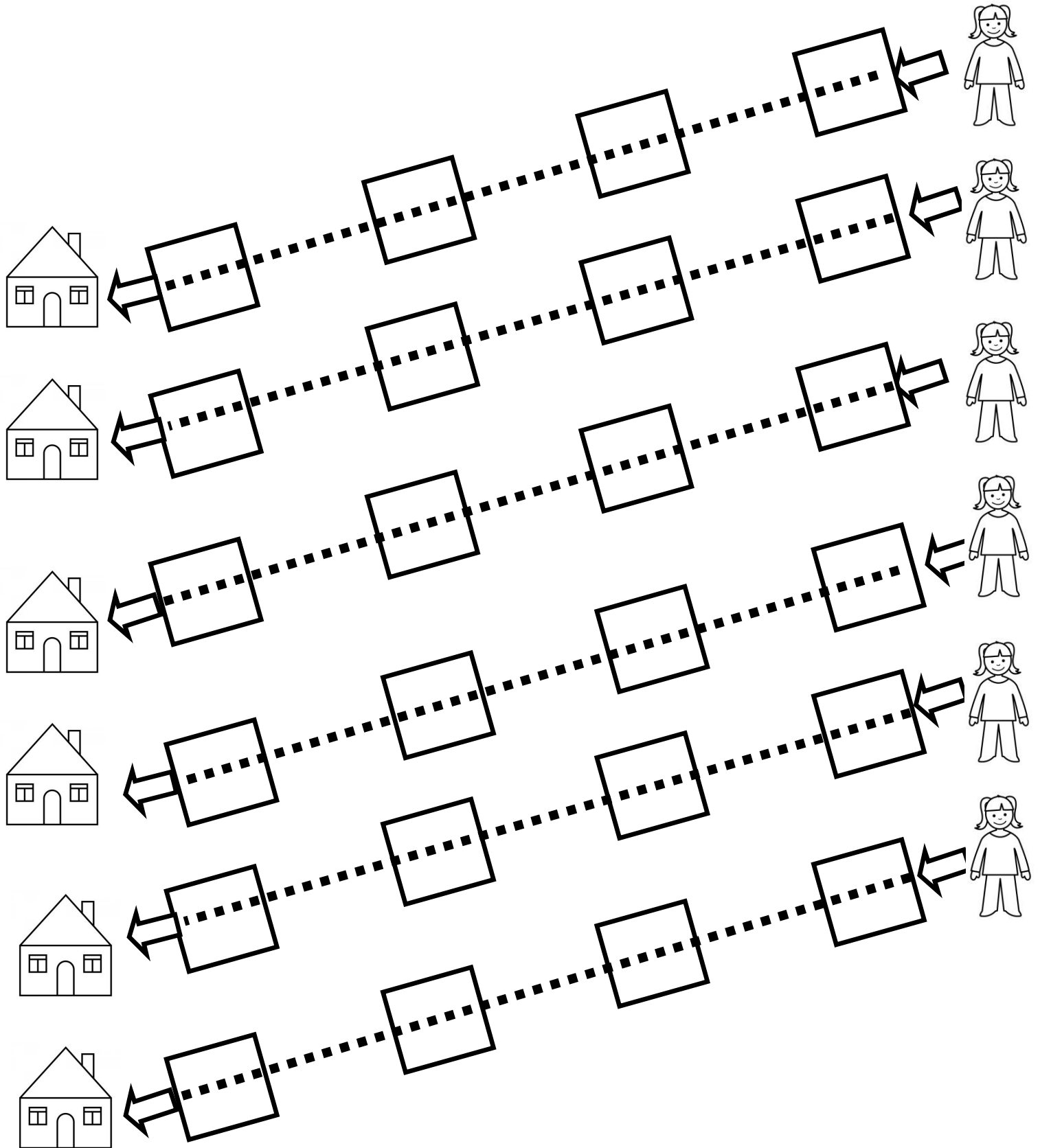

Actividades para mejorar motricidad fina

Sigue con tu lápiz los cuadrados para unir a la niña con su casa

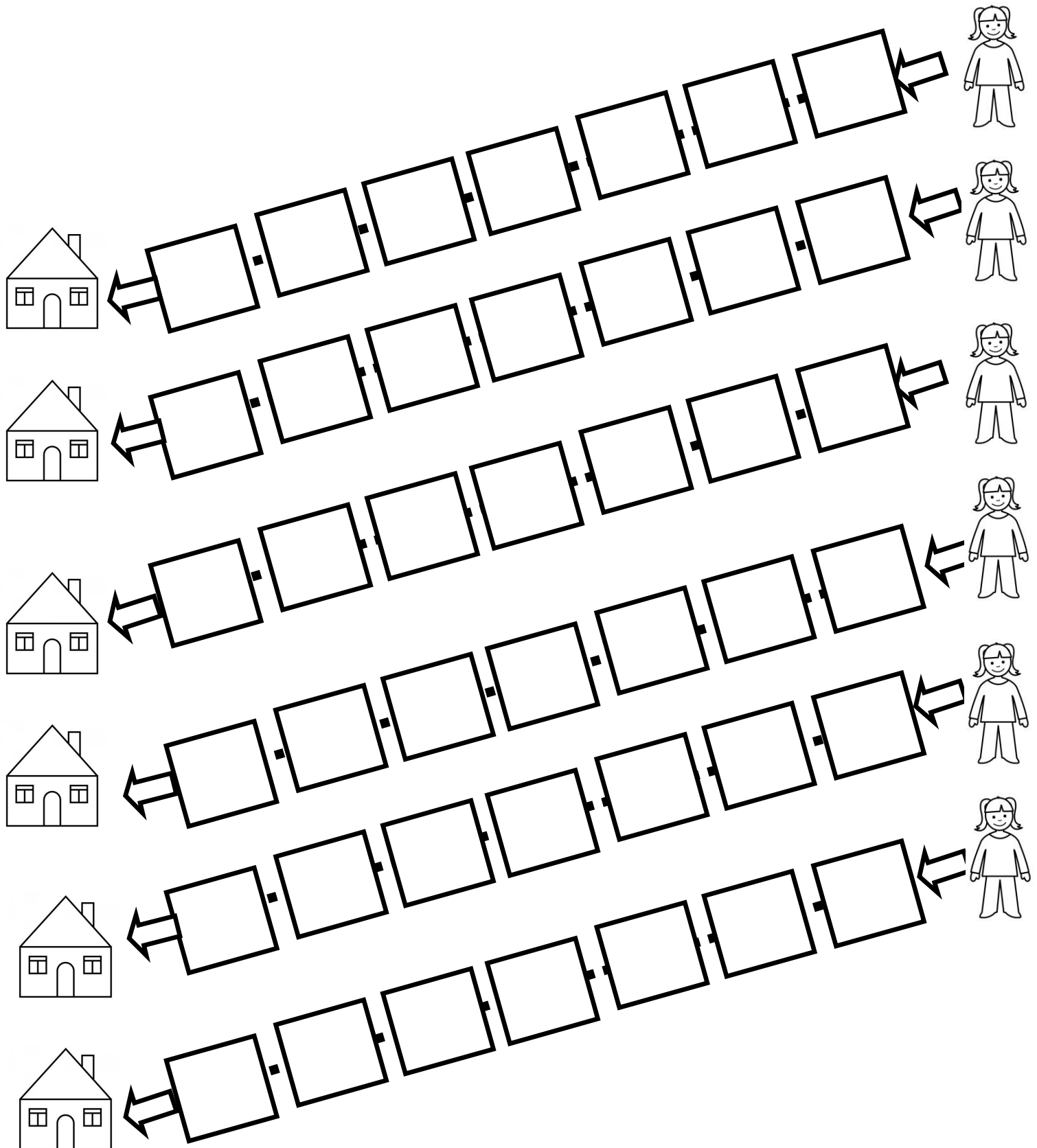

Actividades para mejorar motricidad fina

Sigue con tu lápiz los cuadrados para unir a la niña con su casa

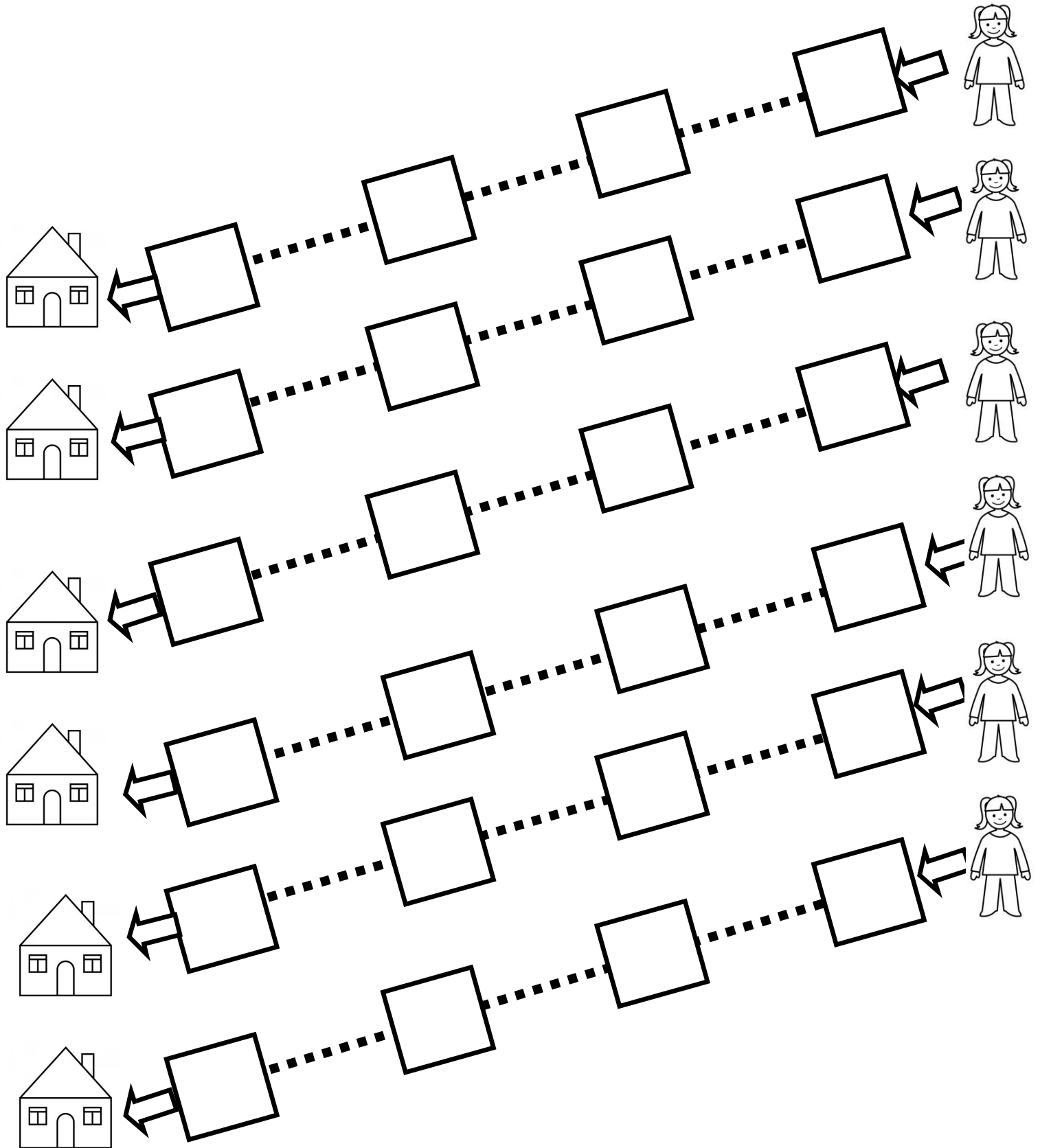

Actividades para mejorar motricidad fina

Sigue con tu lápiz los cuadrados para unir a la niña con su casa

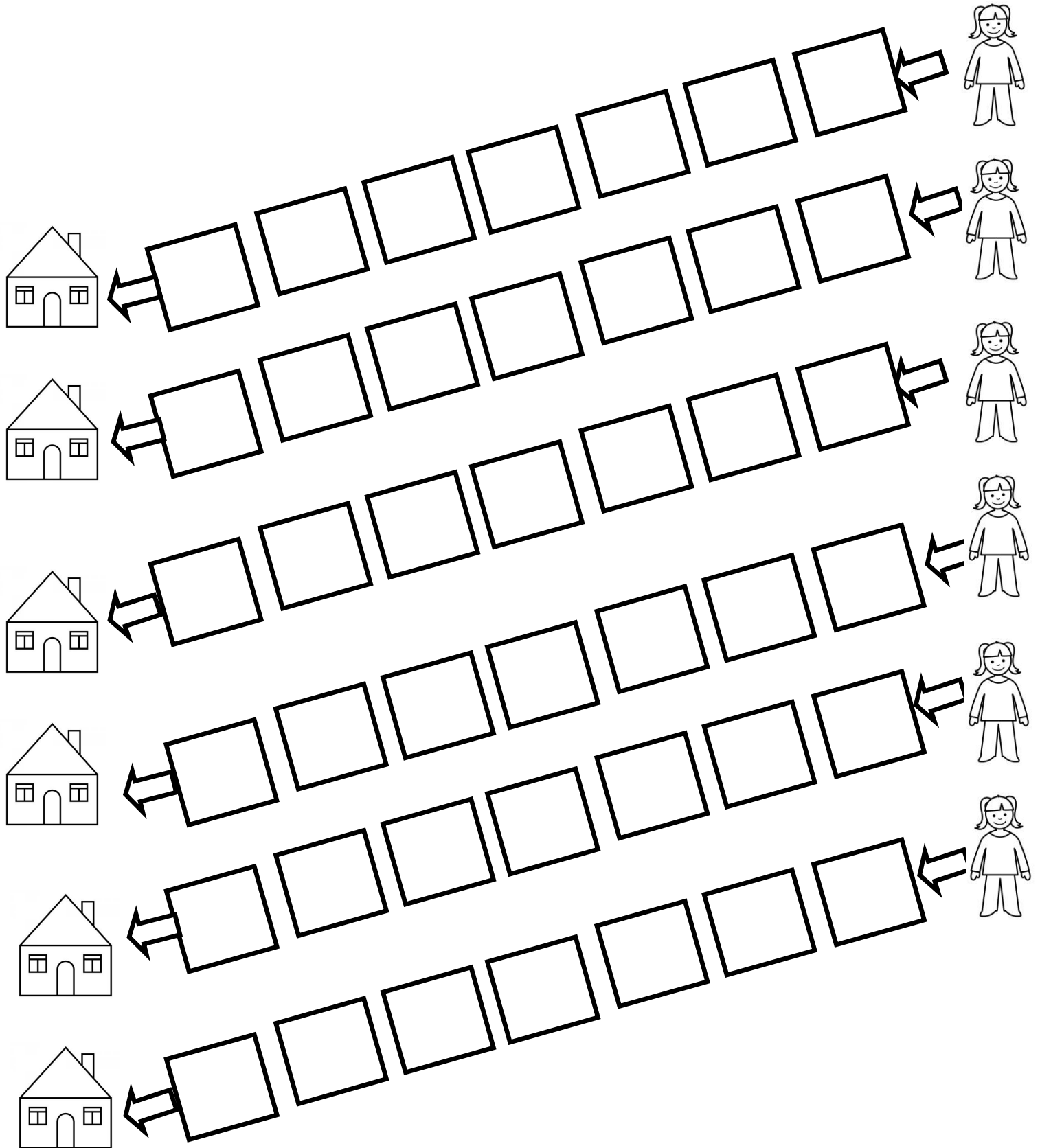

Actividades para mejorar motricidad fina

Sigue con tu lápiz los cuadrados para unir a la niña con su casa

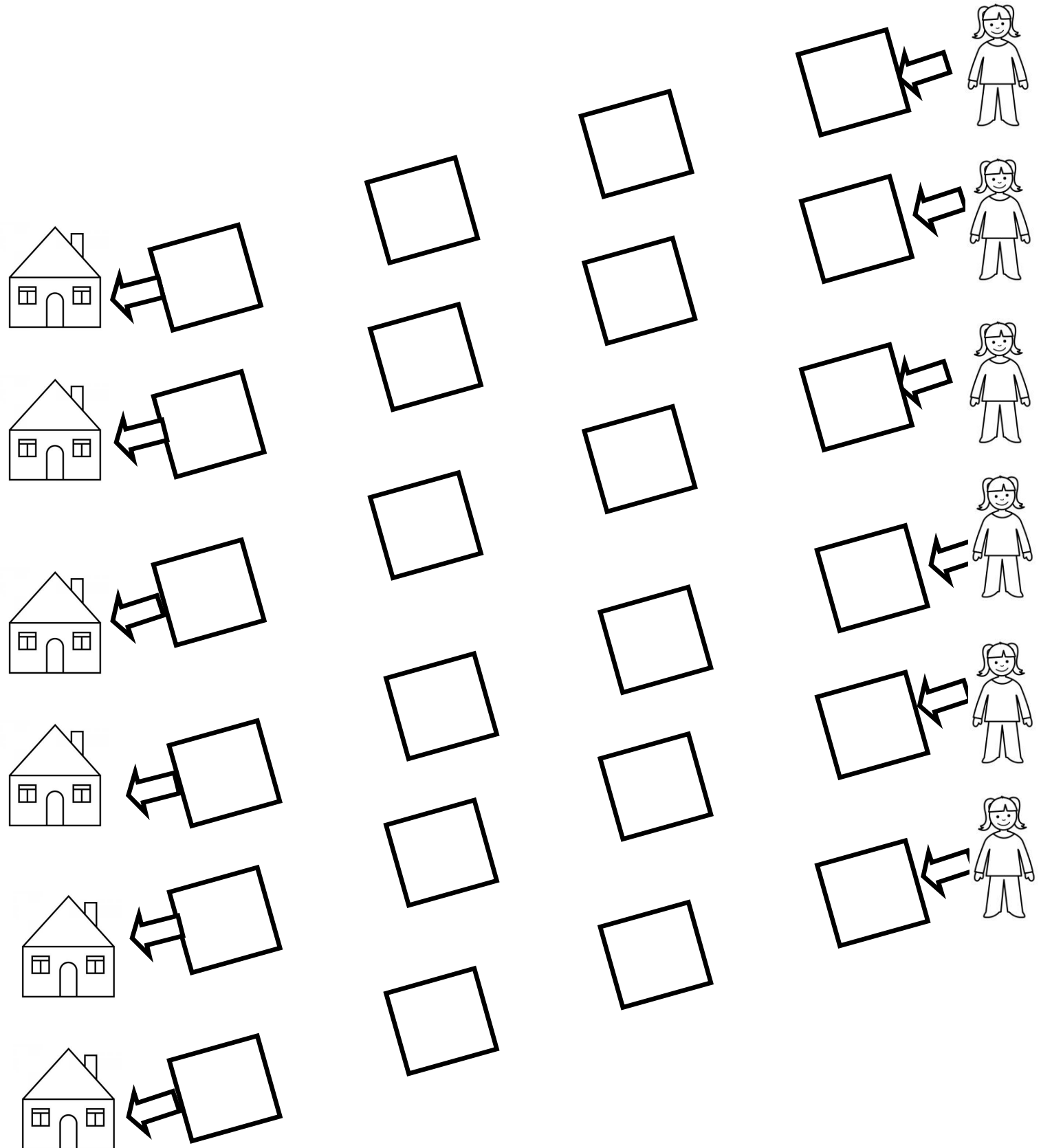

Actividades para mejorar motricidad fina

Sigue con tu lápiz las estrellitas para ir desde el sol a la tierra

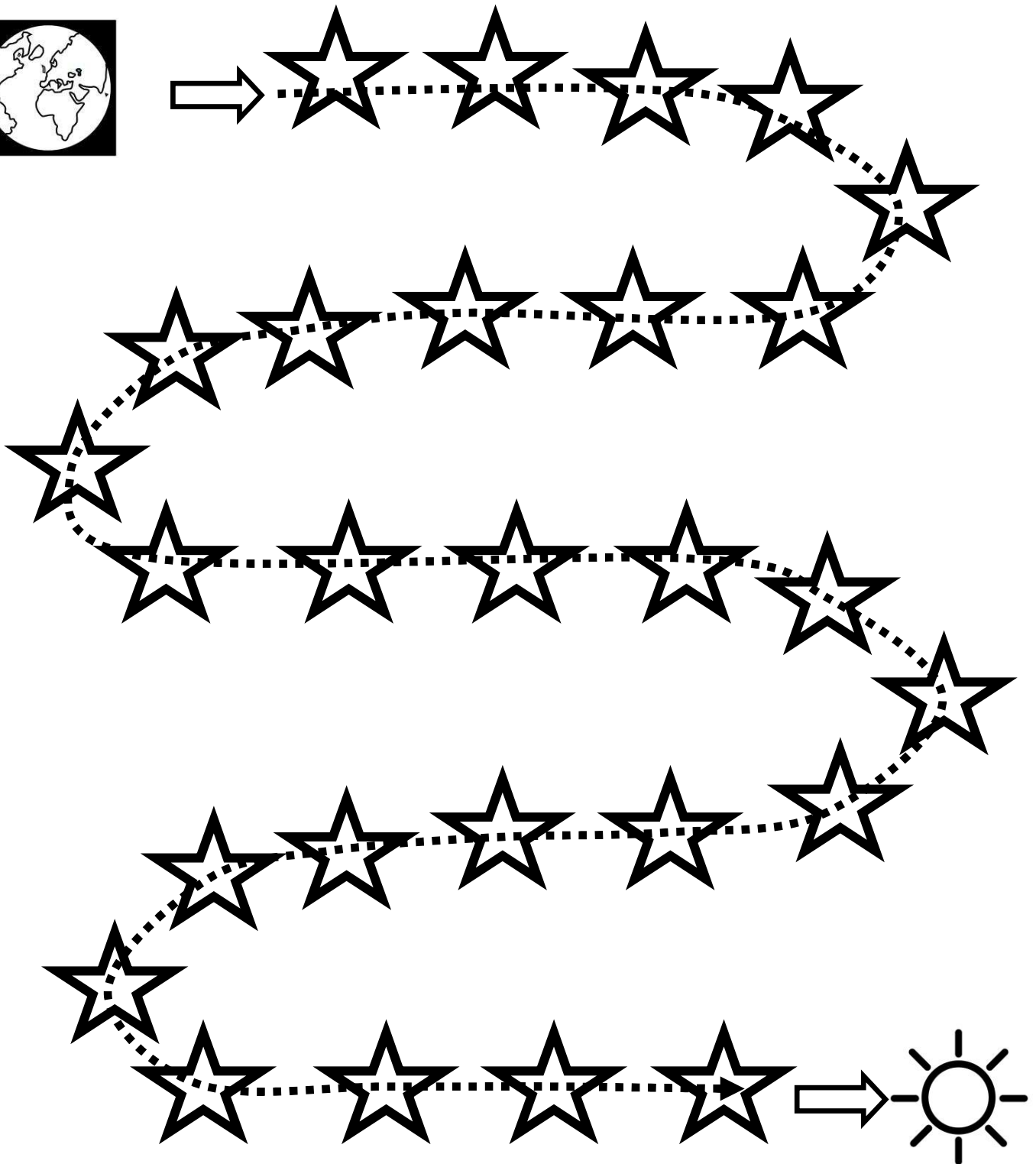

Actividades para mejorar motricidad fina

Sigue con tu lápiz las estrellitas para ir desde el sol a la tierra

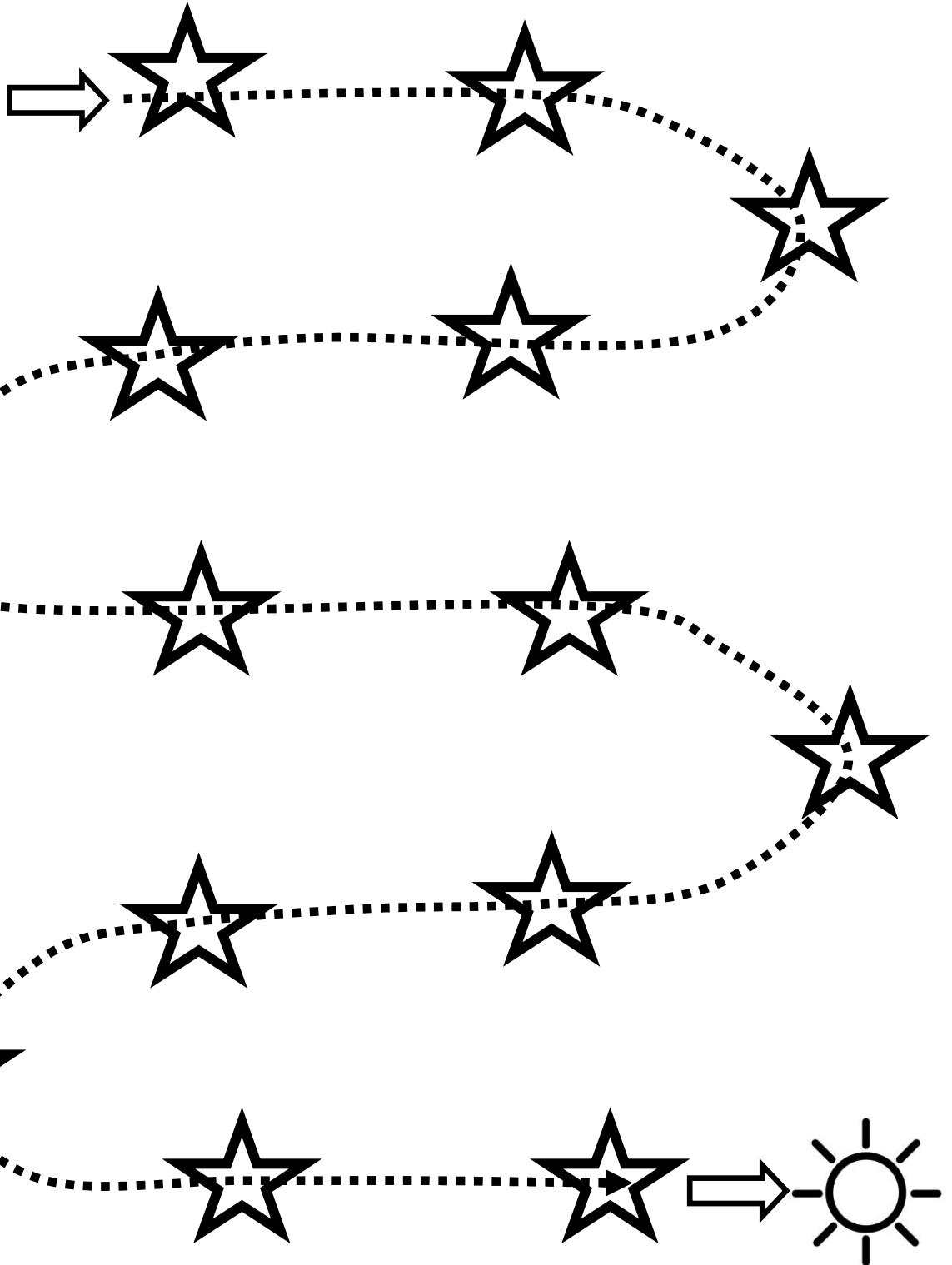

Actividades para mejorar motricidad fina

Sigue con tu lápiz las estrellitas para ir desde el sol a la tierra

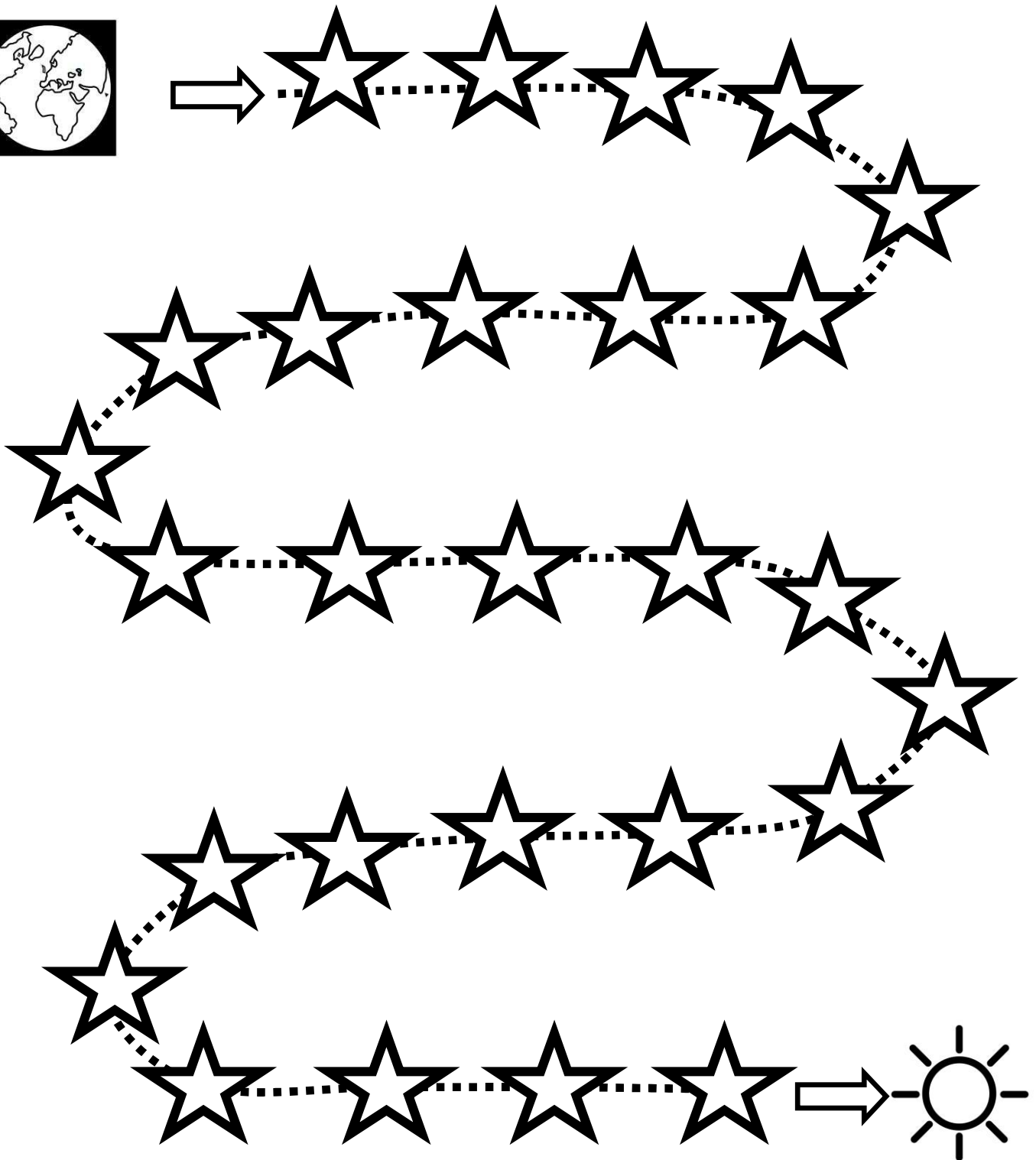

Actividades para mejorar motricidad fina

Sigue con tu lápiz las estrellitas para ir desde el sol a la tierra

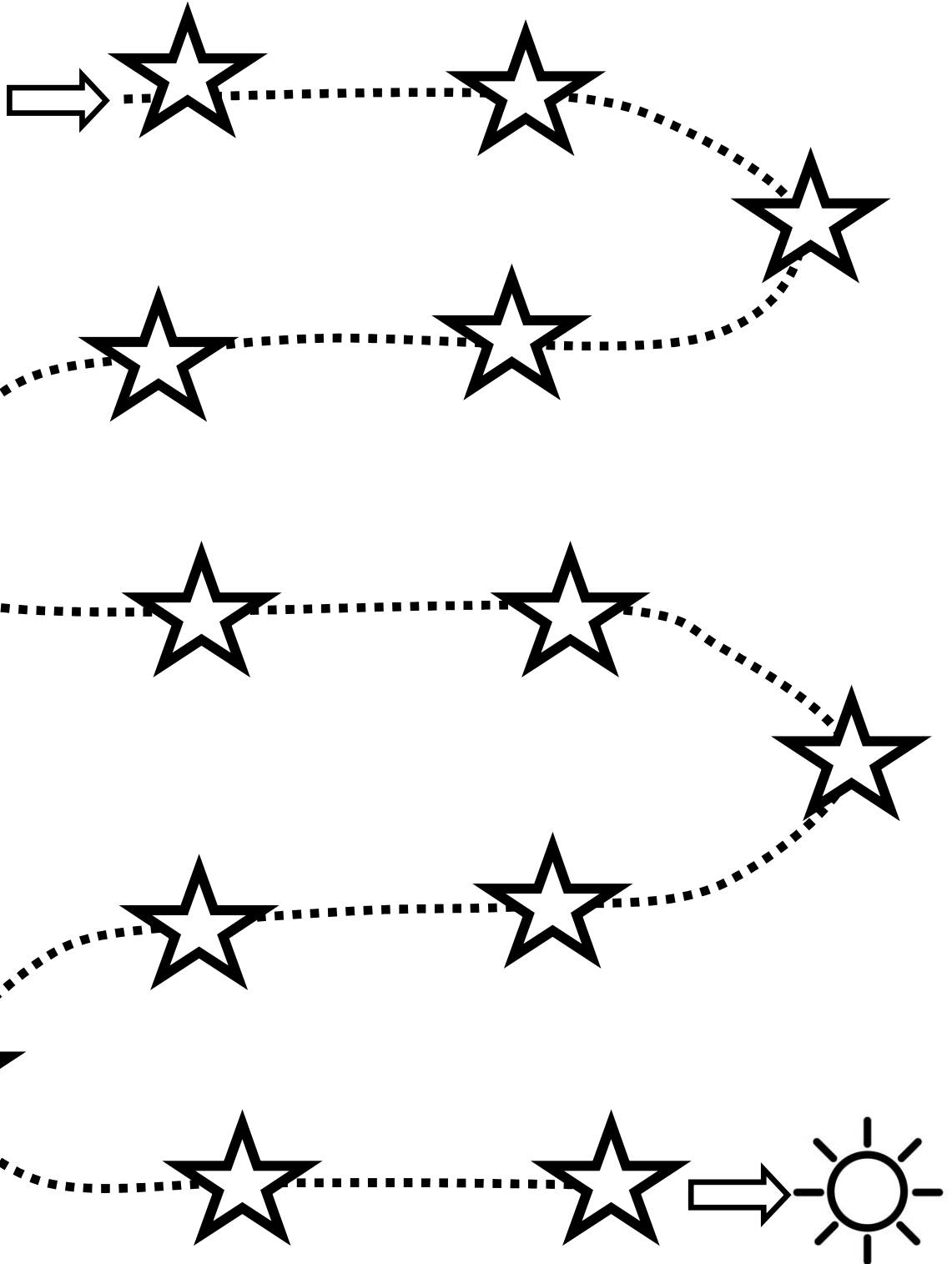

Actividades para mejorar motricidad fina

Sigue con tu lápiz las estrellitas para ir desde el sol a la tierra



Actividades para mejorar motricidad fina

Sigue con tu lápiz las estrellitas para ir desde el sol a la tierra

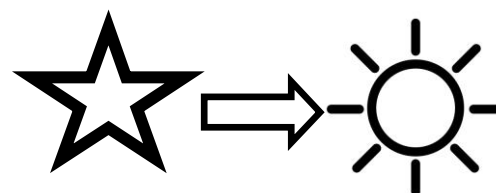
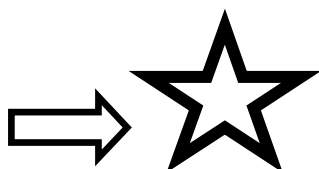

Actividades para mejorar motricidad fina

Sigue con tu lápiz los corazones para unir a la mama y a su bebe

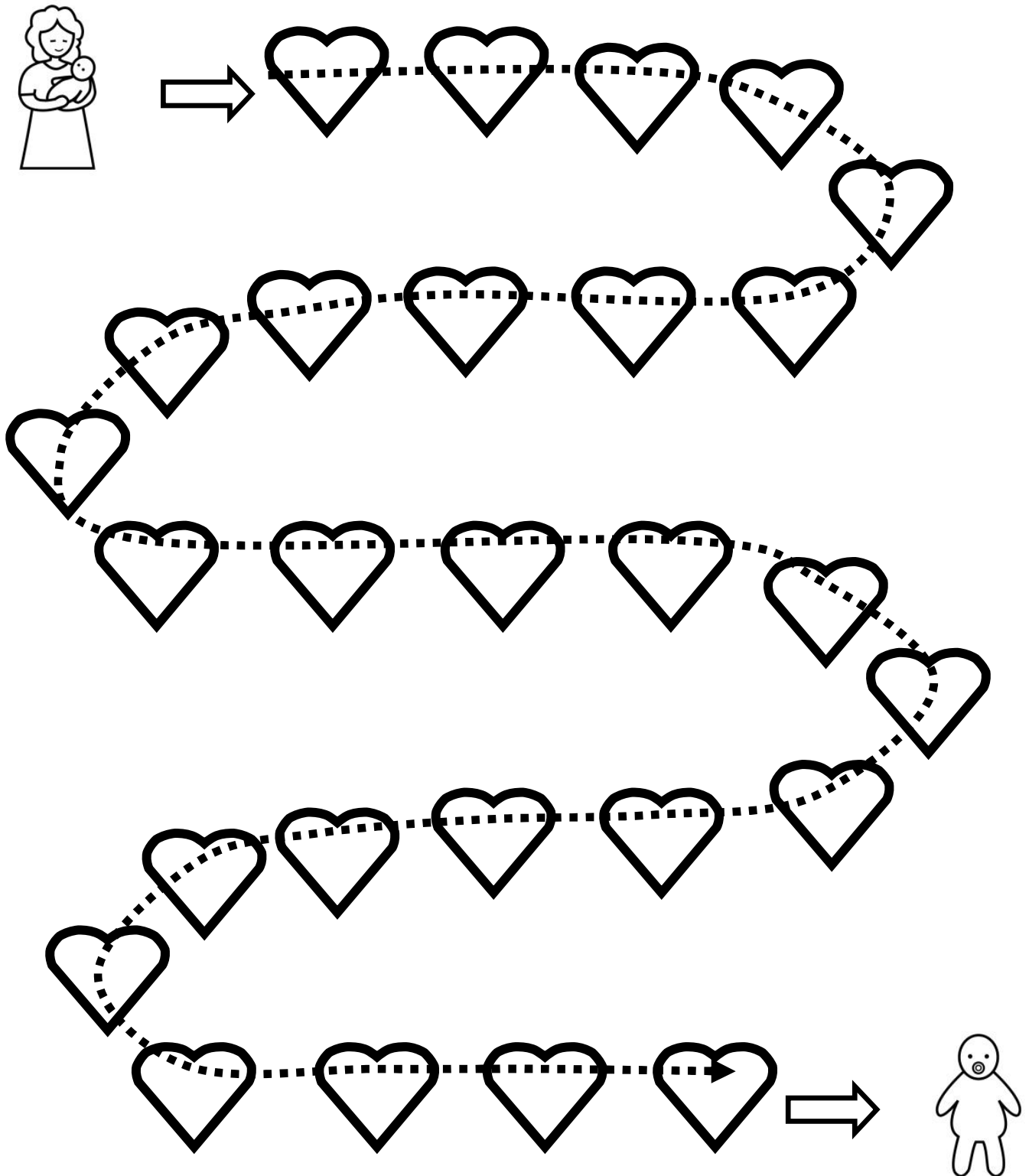

Actividades para mejorar motricidad fina

Sigue con tu lápiz los corazones para unir a la mama y a su bebe

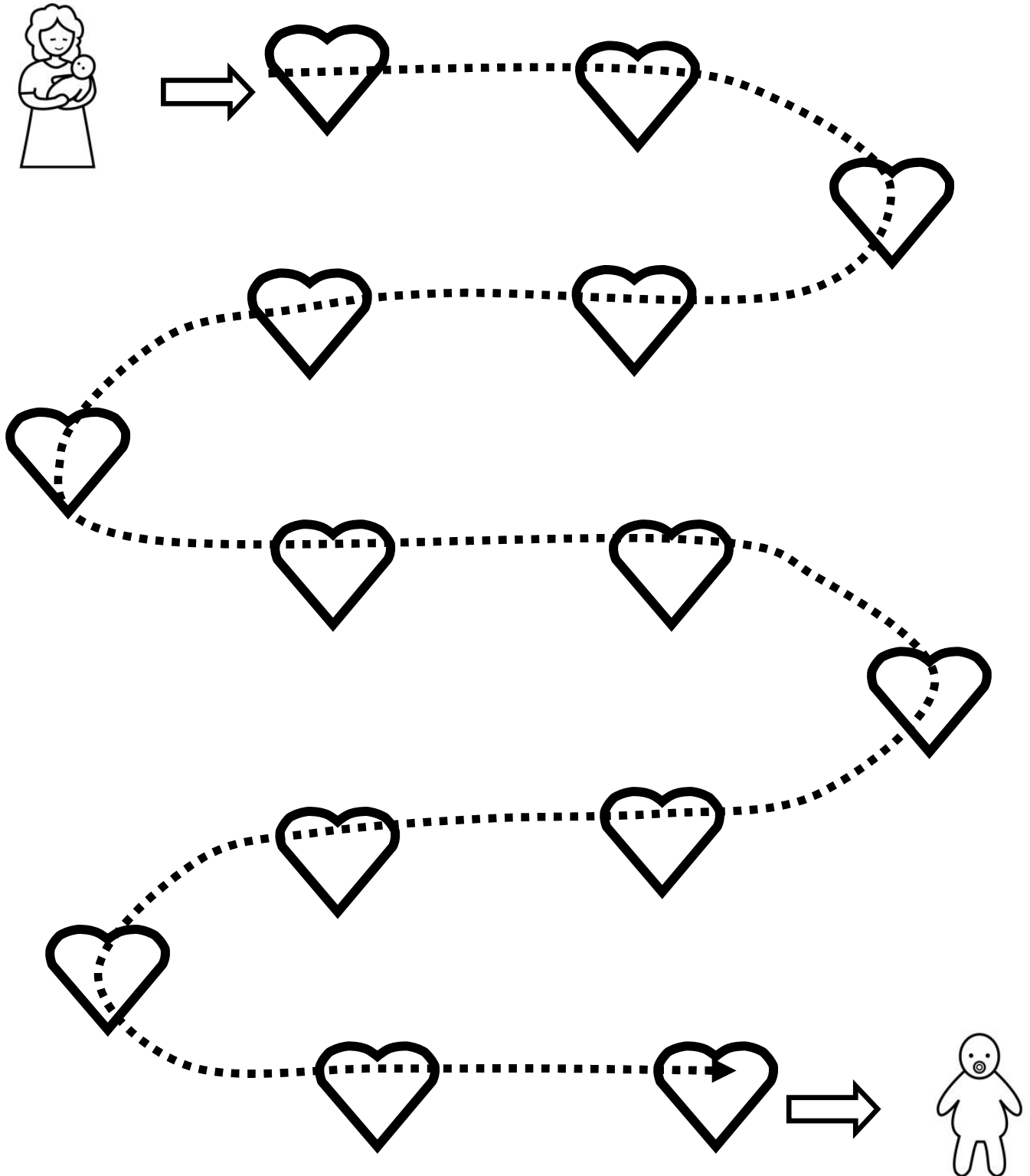

Actividades para mejorar motricidad fina

Sigue con tu lápiz los corazones para unir a la mama y a su bebe

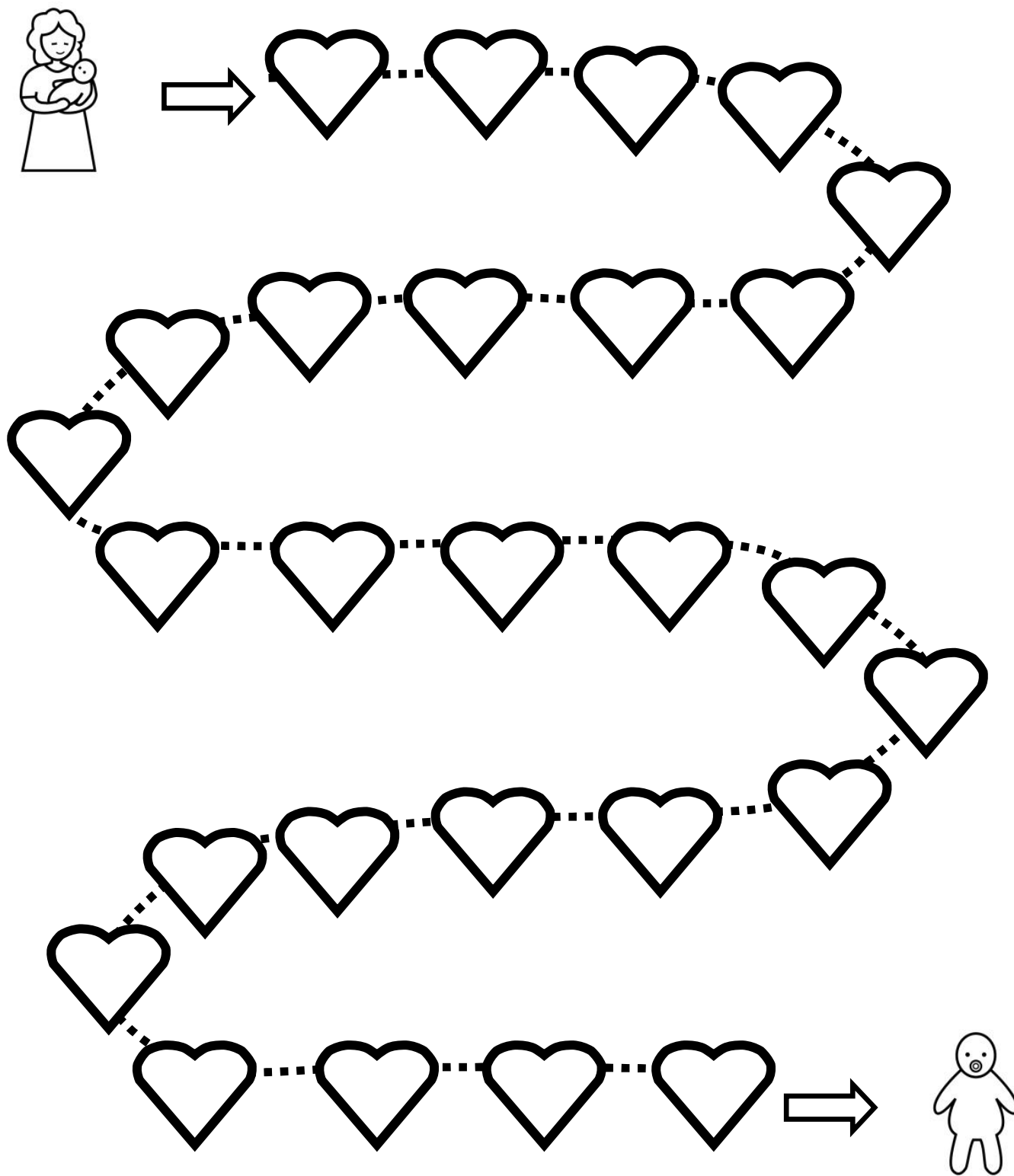

Actividades para mejorar motricidad fina

Sigue con tu lápiz los corazones para unir a la mama y a su bebe

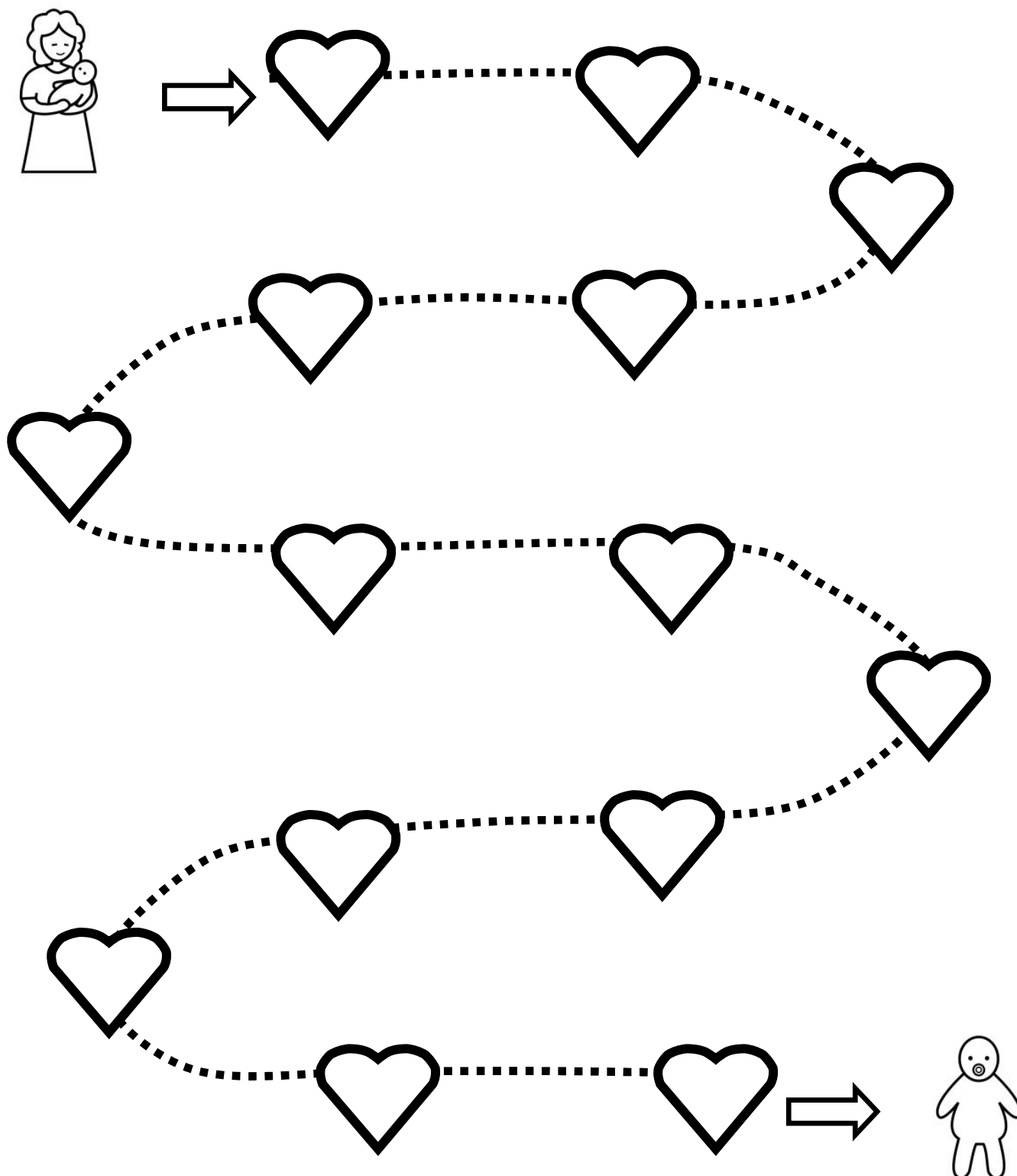

Actividades para mejorar motricidad fina

Sigue con tu lápiz los corazones para unir a la mama y a su bebe

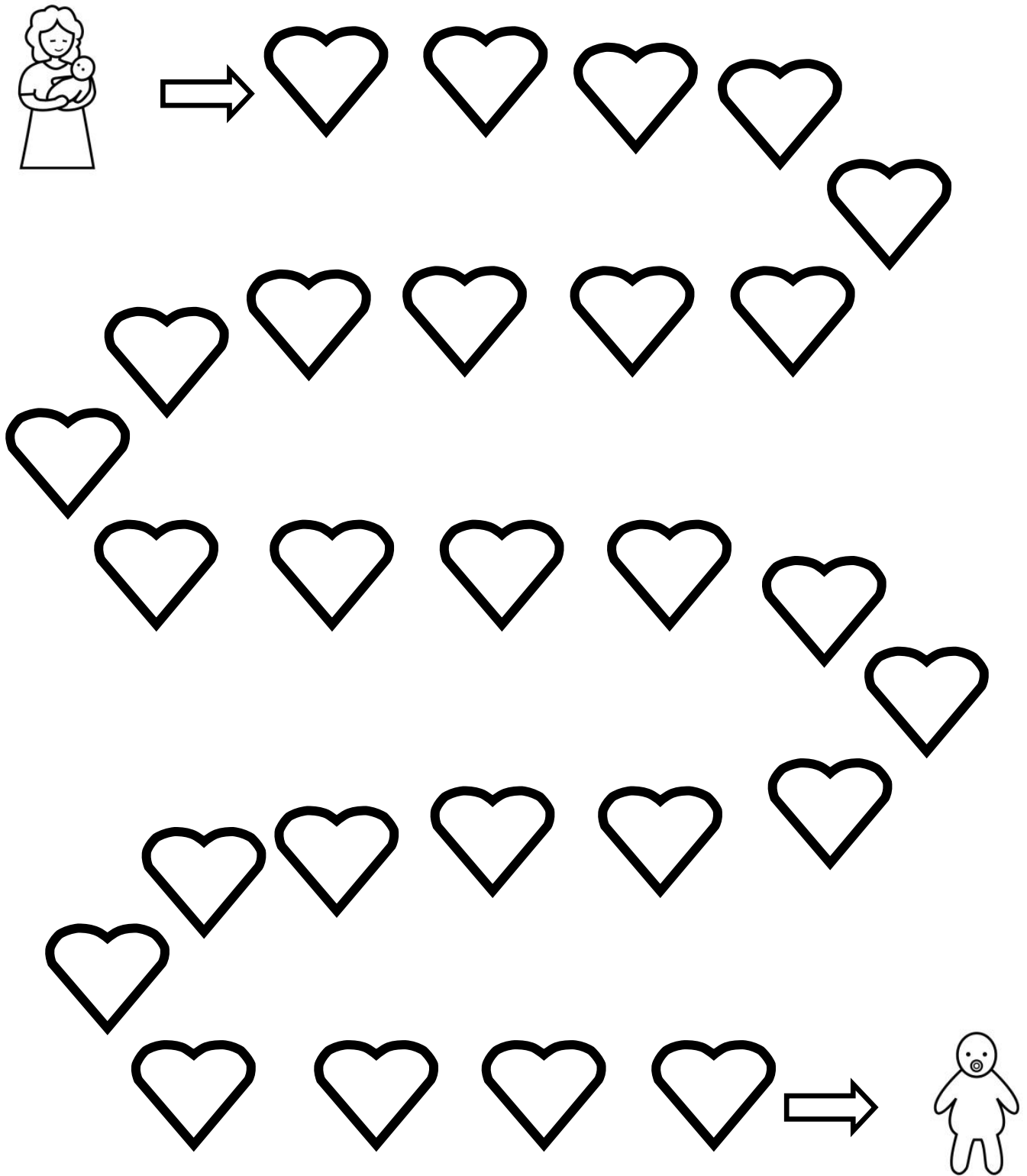

Actividades para mejorar motricidad fina

Sigue con tu lápiz los corazones para unir a la mama y a su bebe

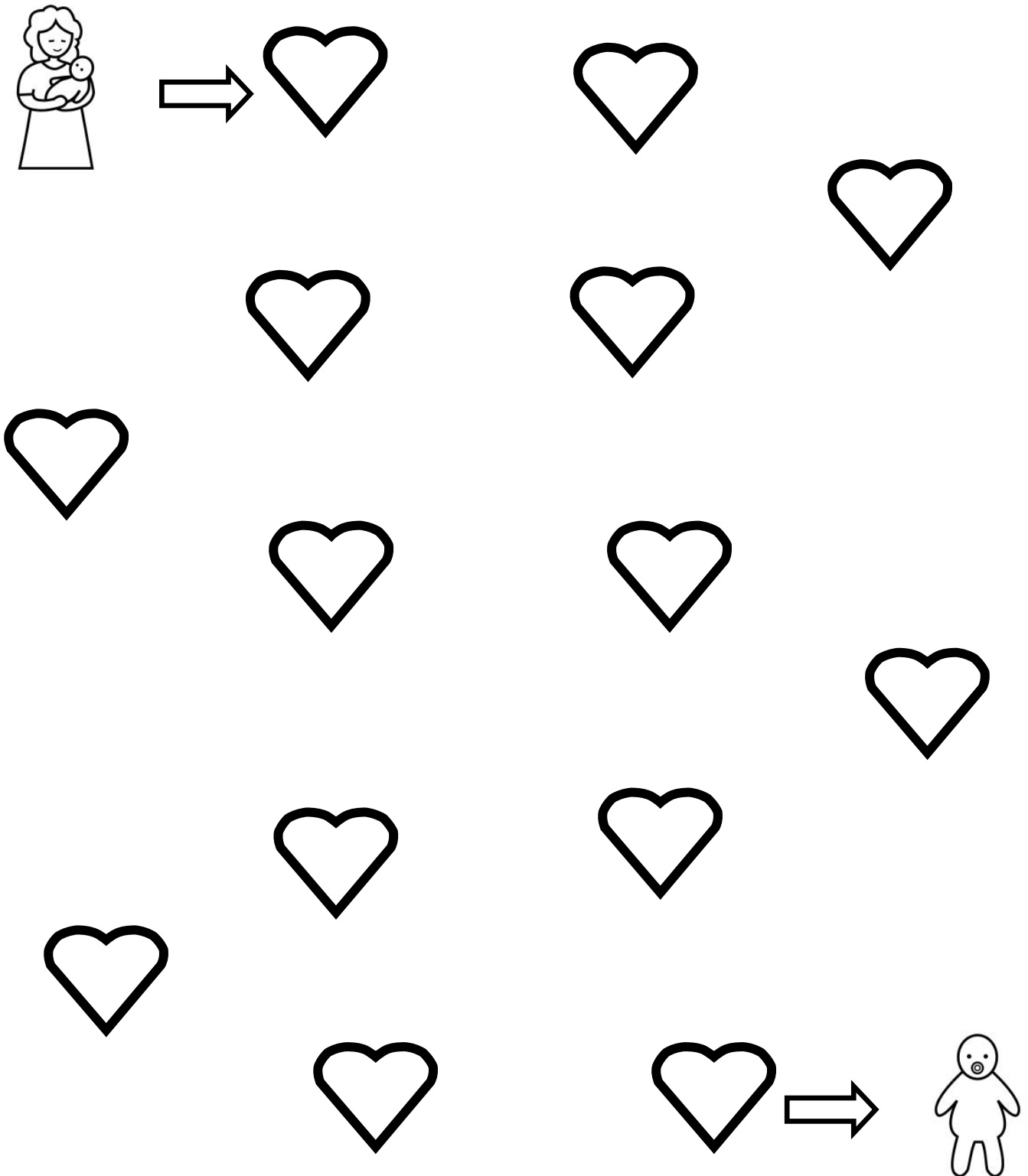

Actividades para mejorar motricidad fina

Sigue las caras para unir al niño y a la niña

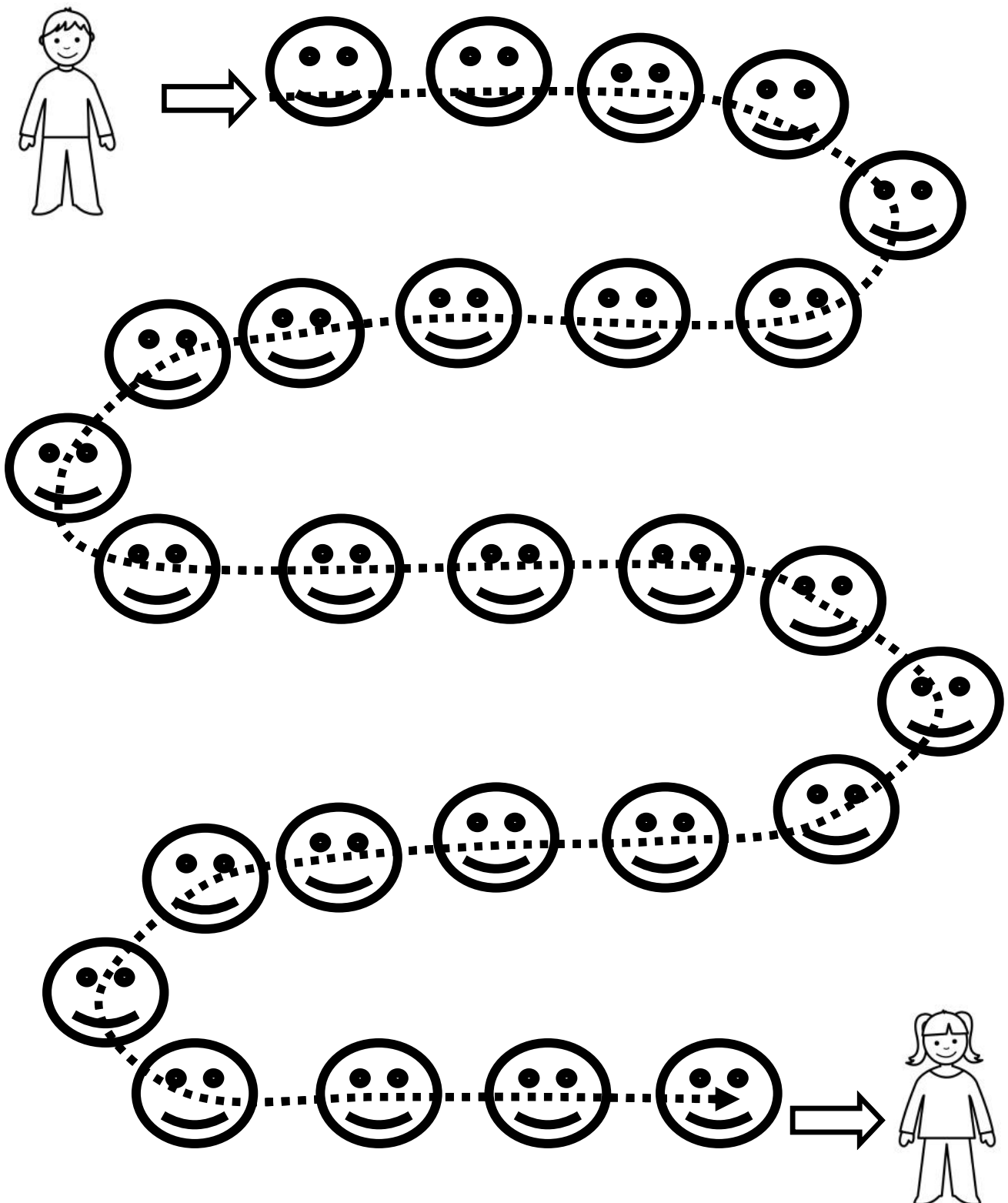

Actividades para mejorar motricidad fina

Sigue las caras para unir al niño y a la niña

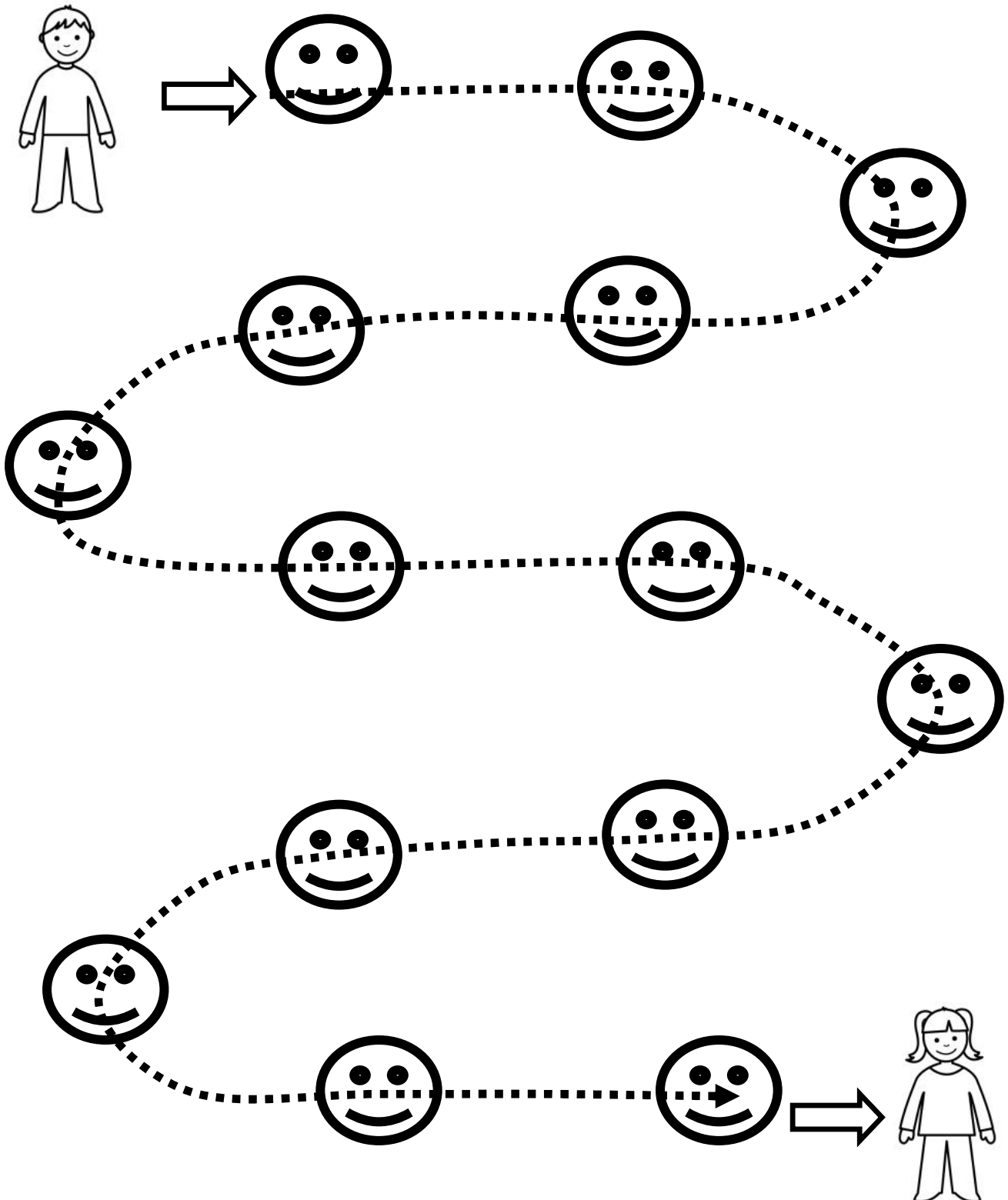

Actividades para mejorar motricidad fina

Sigue las caras para unir al niño y a la niña

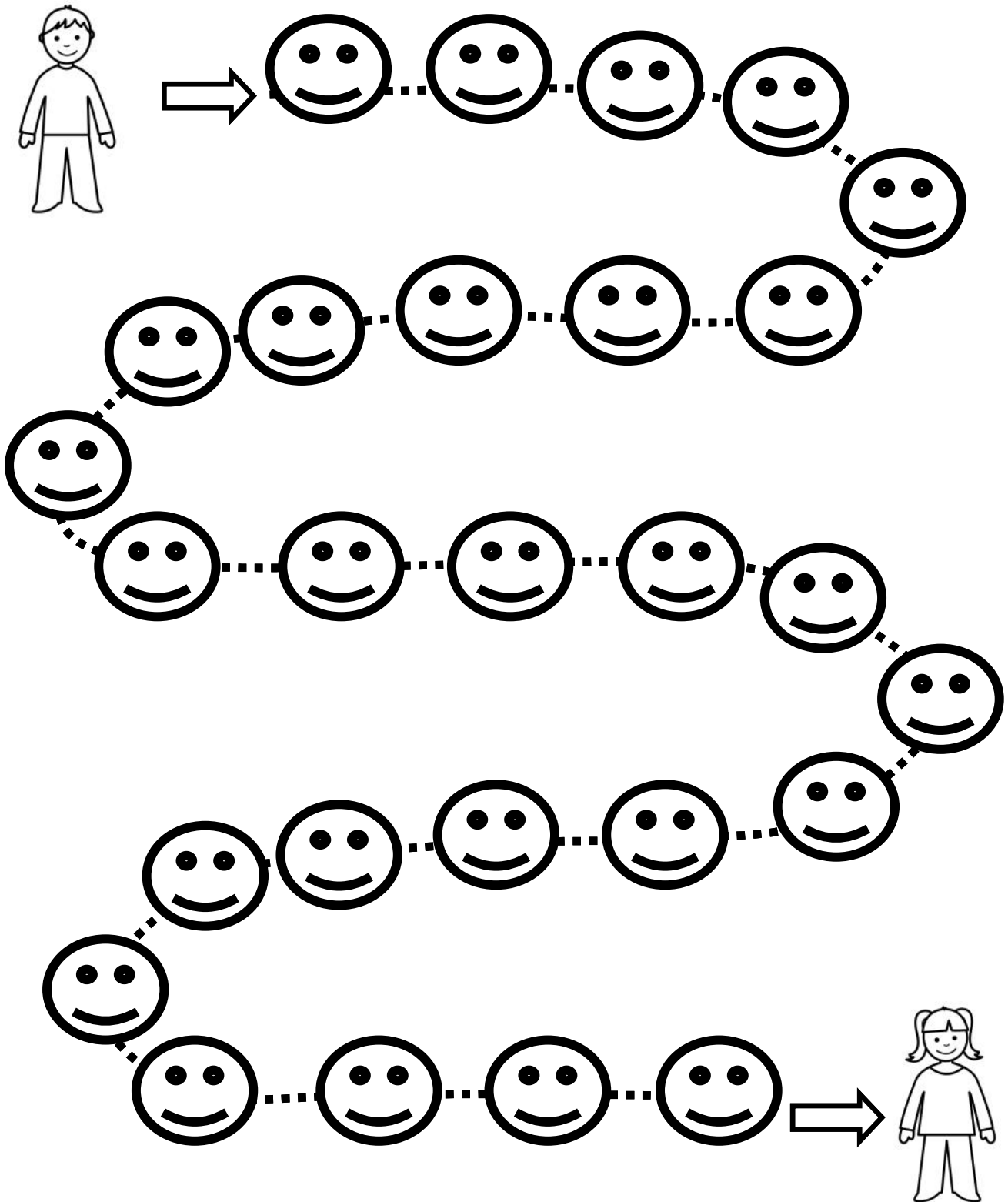

Actividades para mejorar motricidad fina

Sigue las caras para unir al niño y a la niña

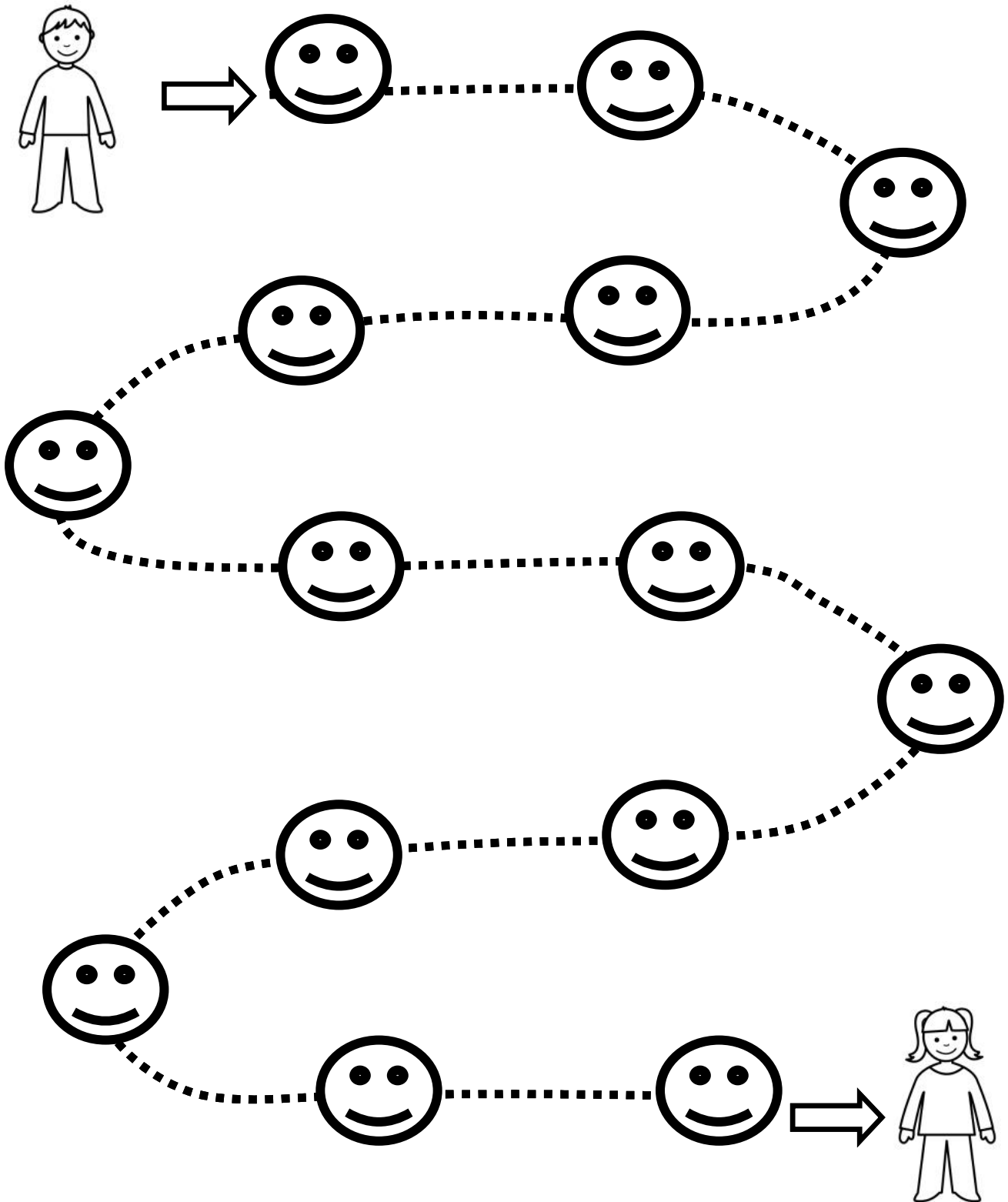

Actividades para mejorar motricidad fina

Sigue las caras para unir al niño y a la niña

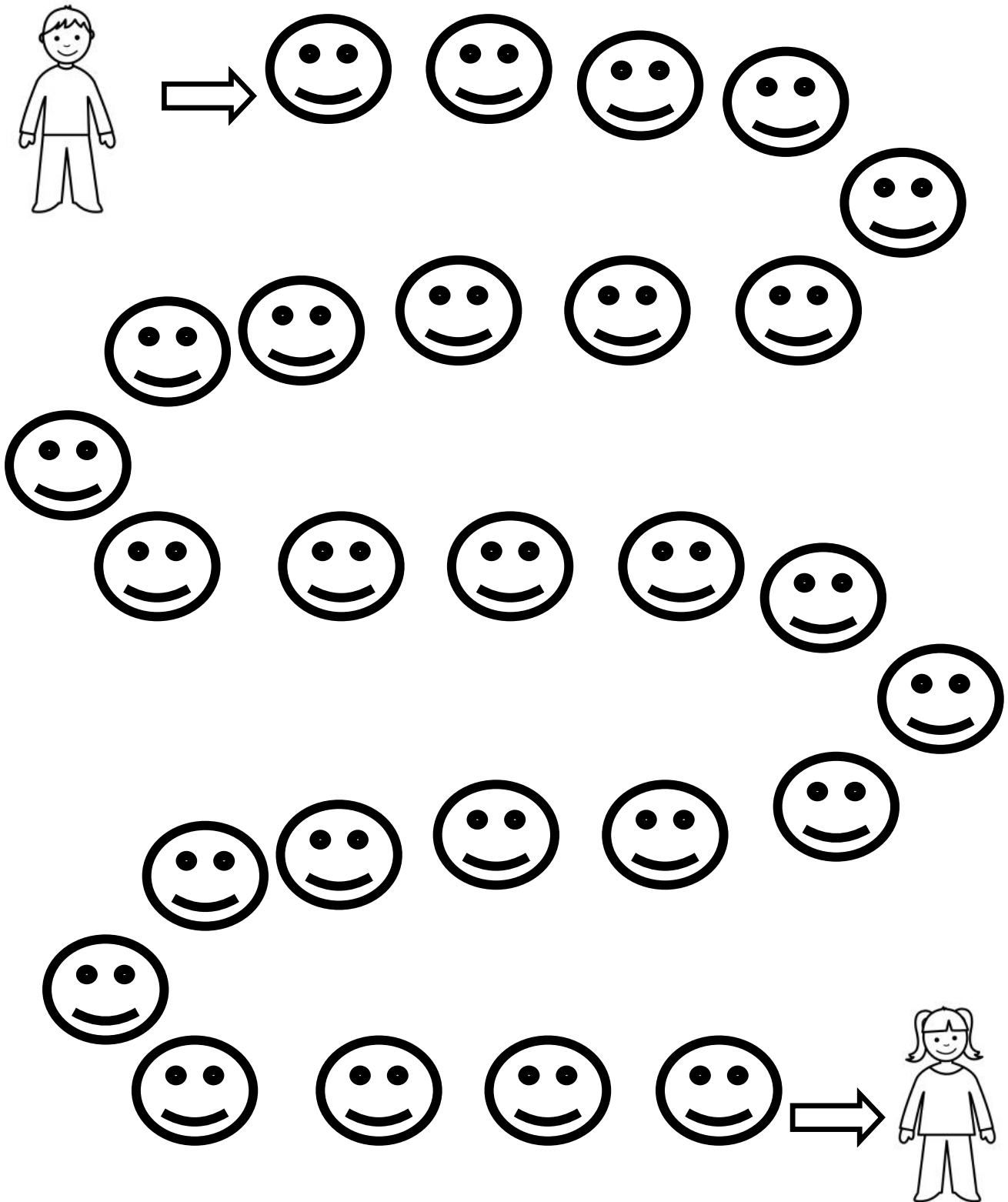

Actividades para mejorar motricidad fina

Sigue las caras para unir al niño y a la niña

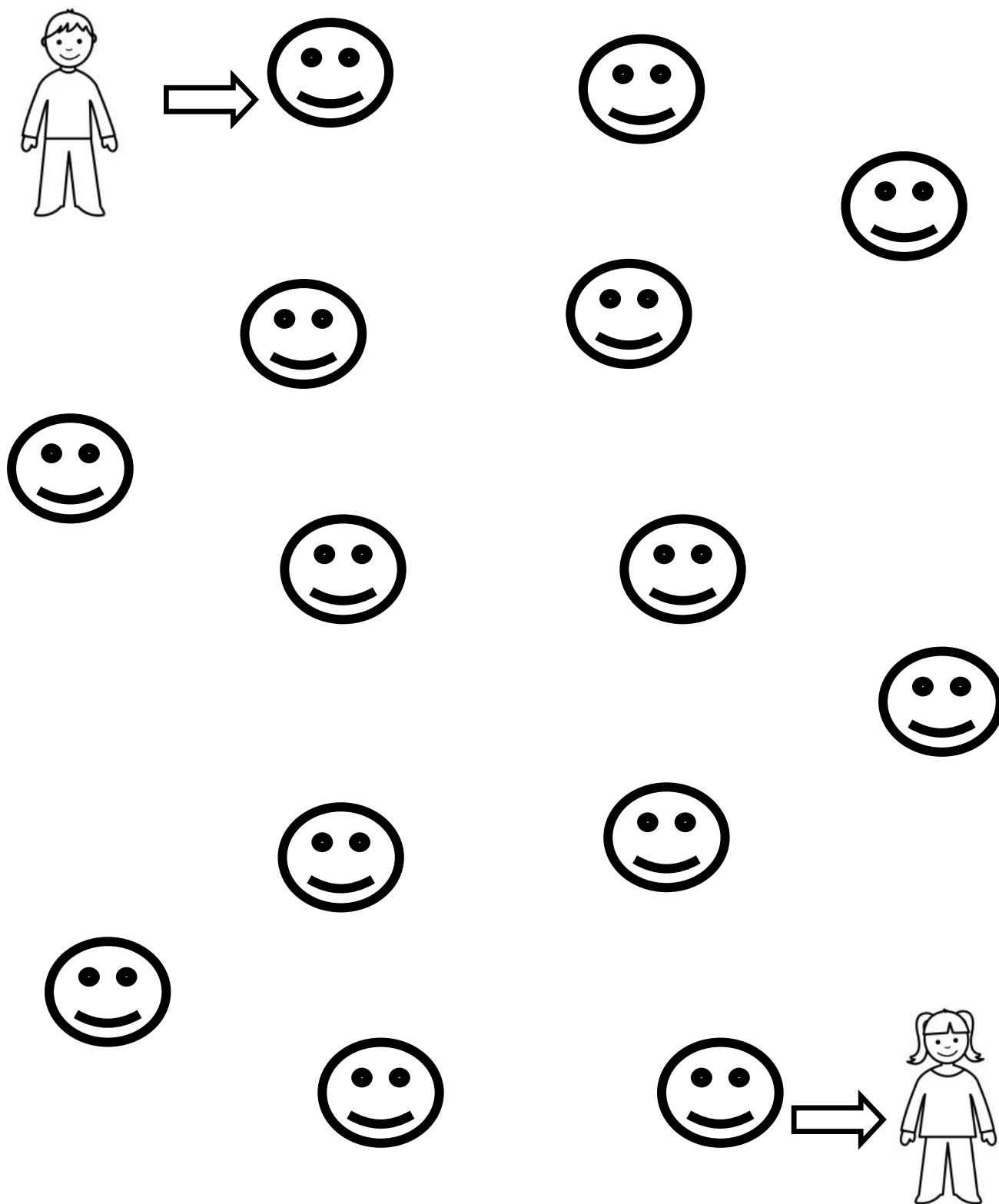

Actividades para mejorar motricidad fina

Sigue los círculos para unir al niño con la pelota

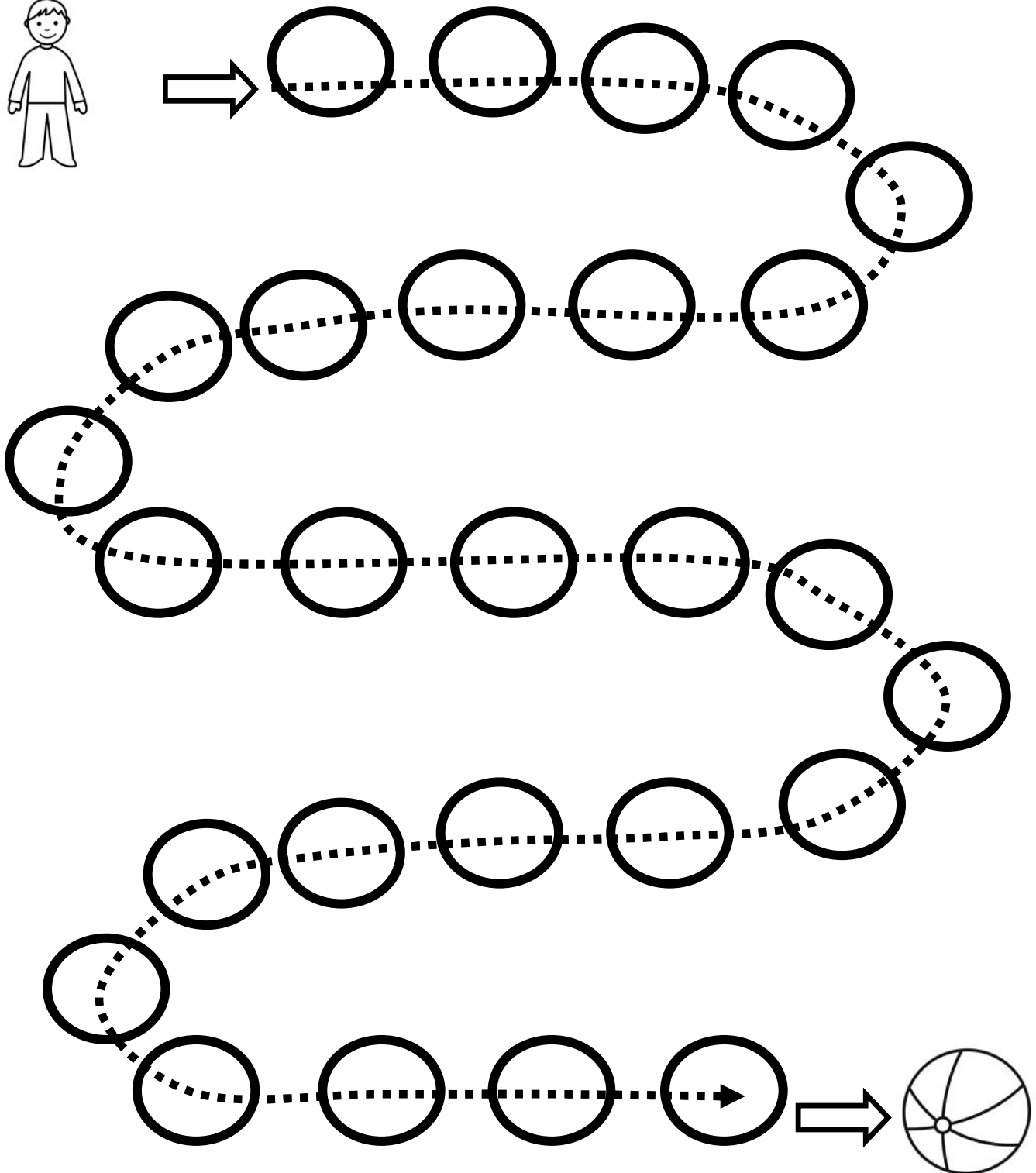
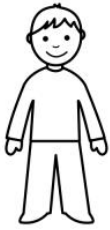

Actividades para mejorar motricidad fina

Sigue los círculos para unir al niño con la pelota

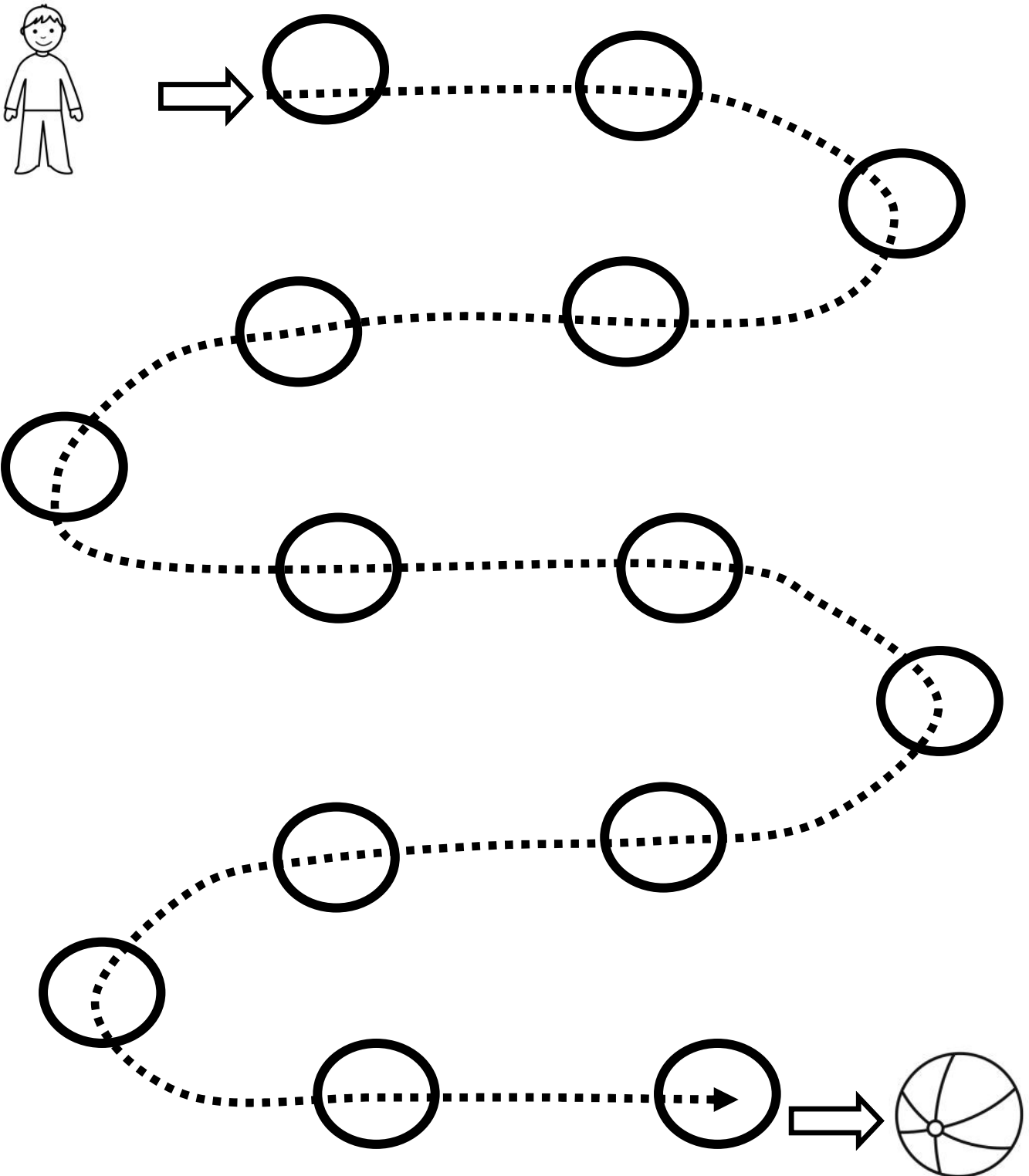

Actividades para mejorar motricidad fina

Sigue los círculos para unir al niño con la pelota

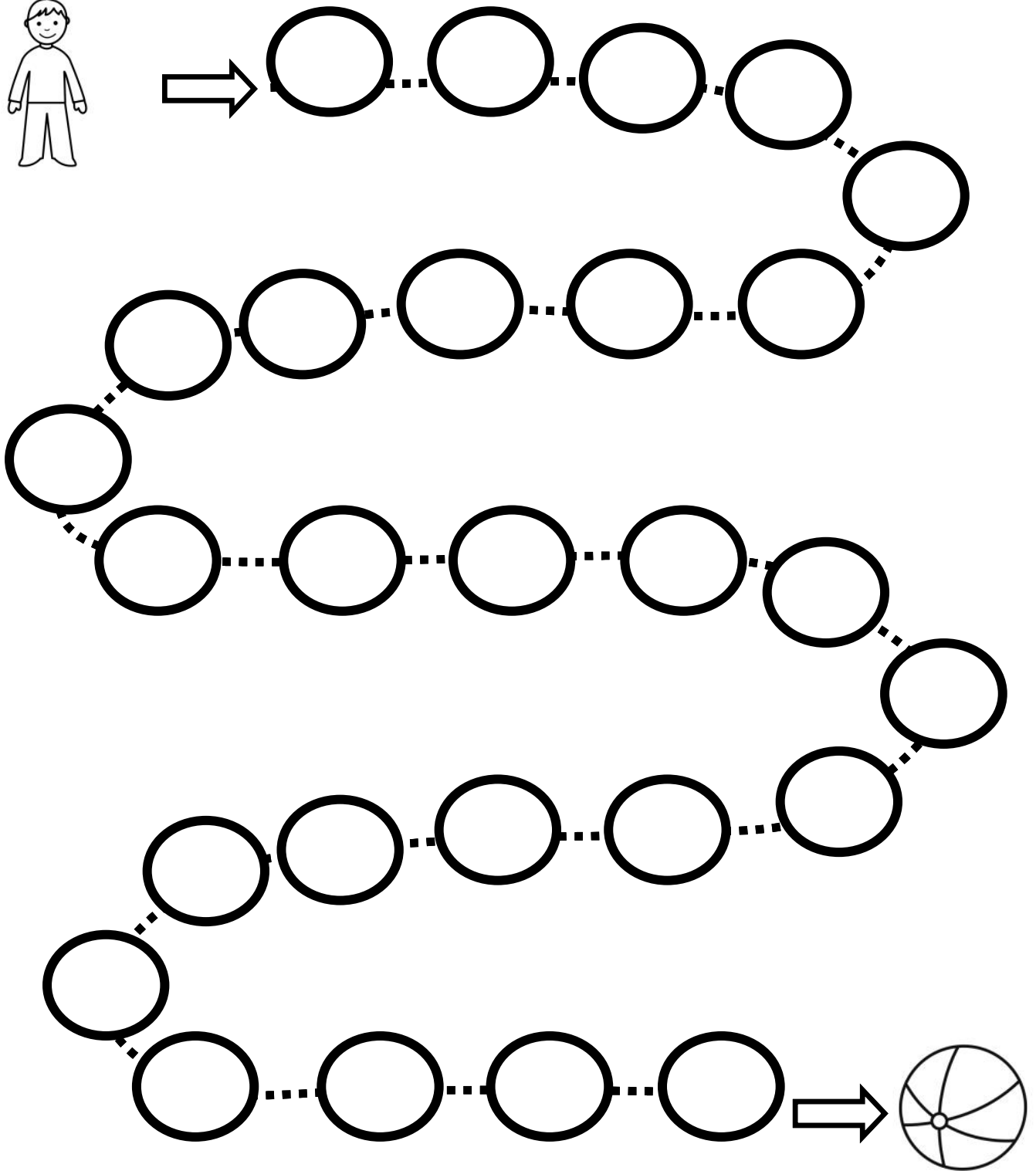
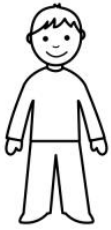

Actividades para mejorar motricidad fina

Sigue los círculos para unir al niño con la pelota

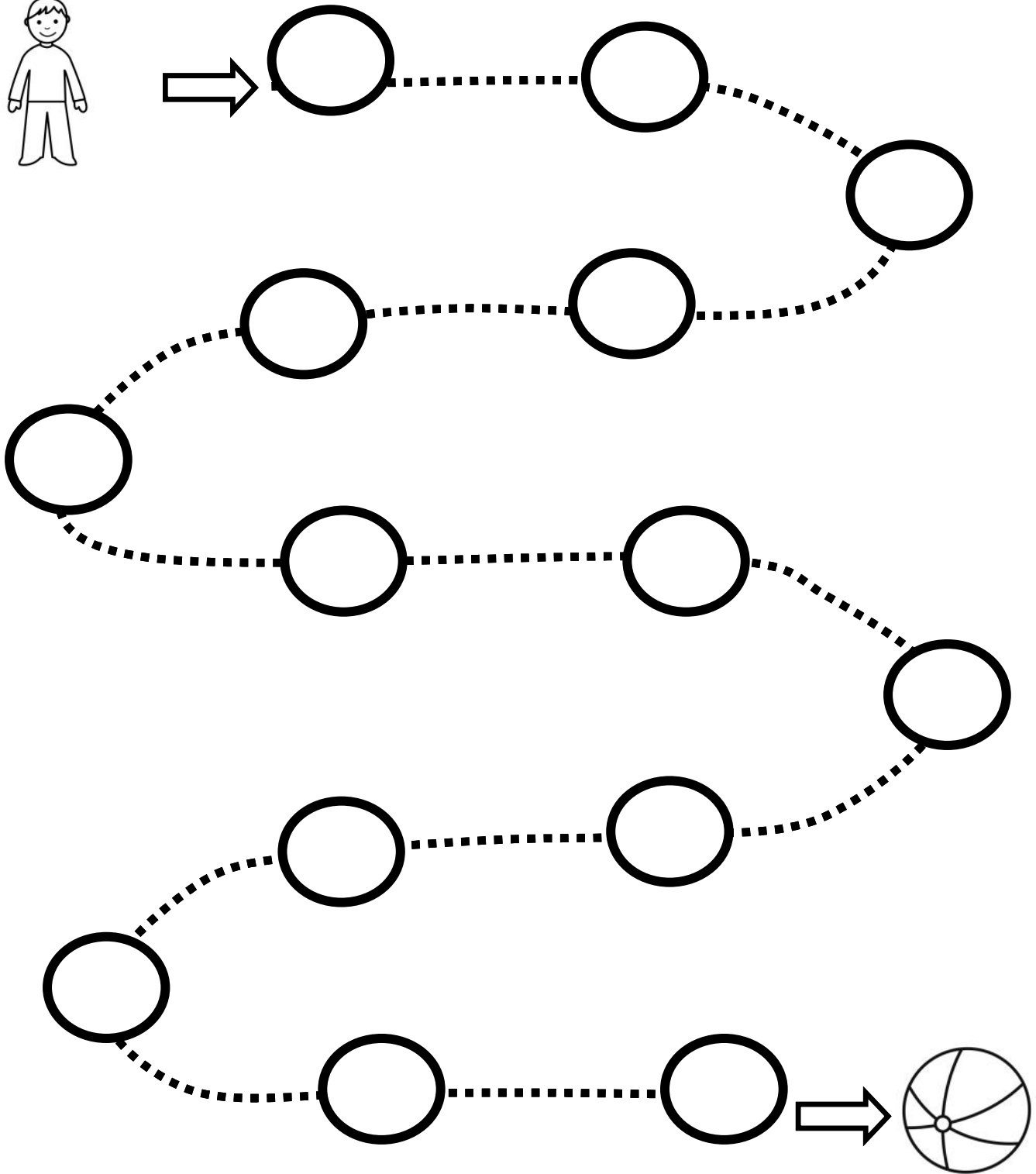
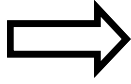
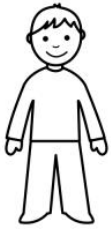

Actividades para mejorar motricidad fina

Sigue los círculos para unir al niño con la pelota

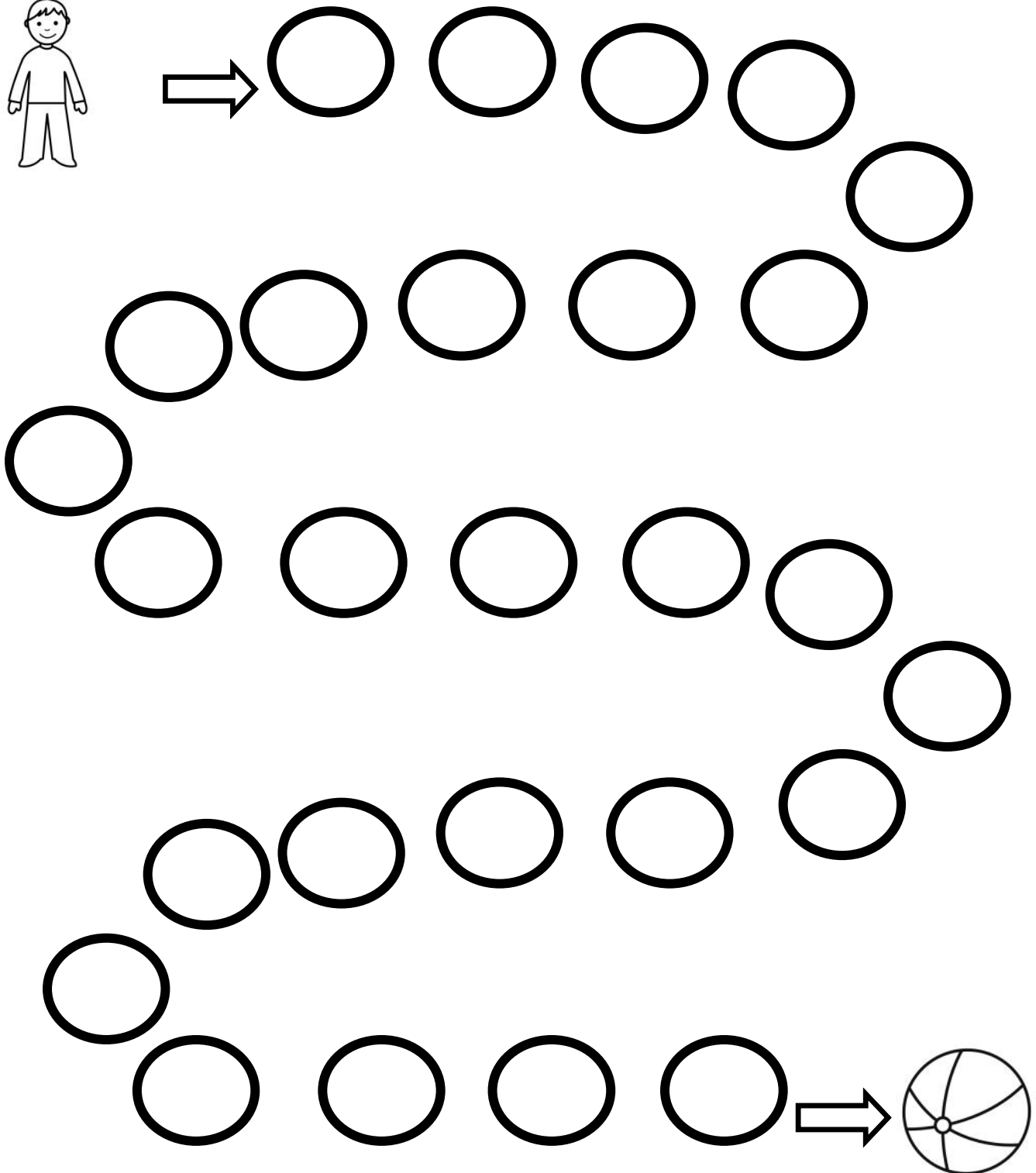
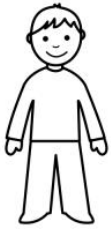

Actividades para mejorar motricidad fina

Sigue los círculos para unir al niño con la pelota

