

Actividades para mejorar motricidad fina

Sigue con tu lápiz las estrellitas para ir desde el sol a la tierra

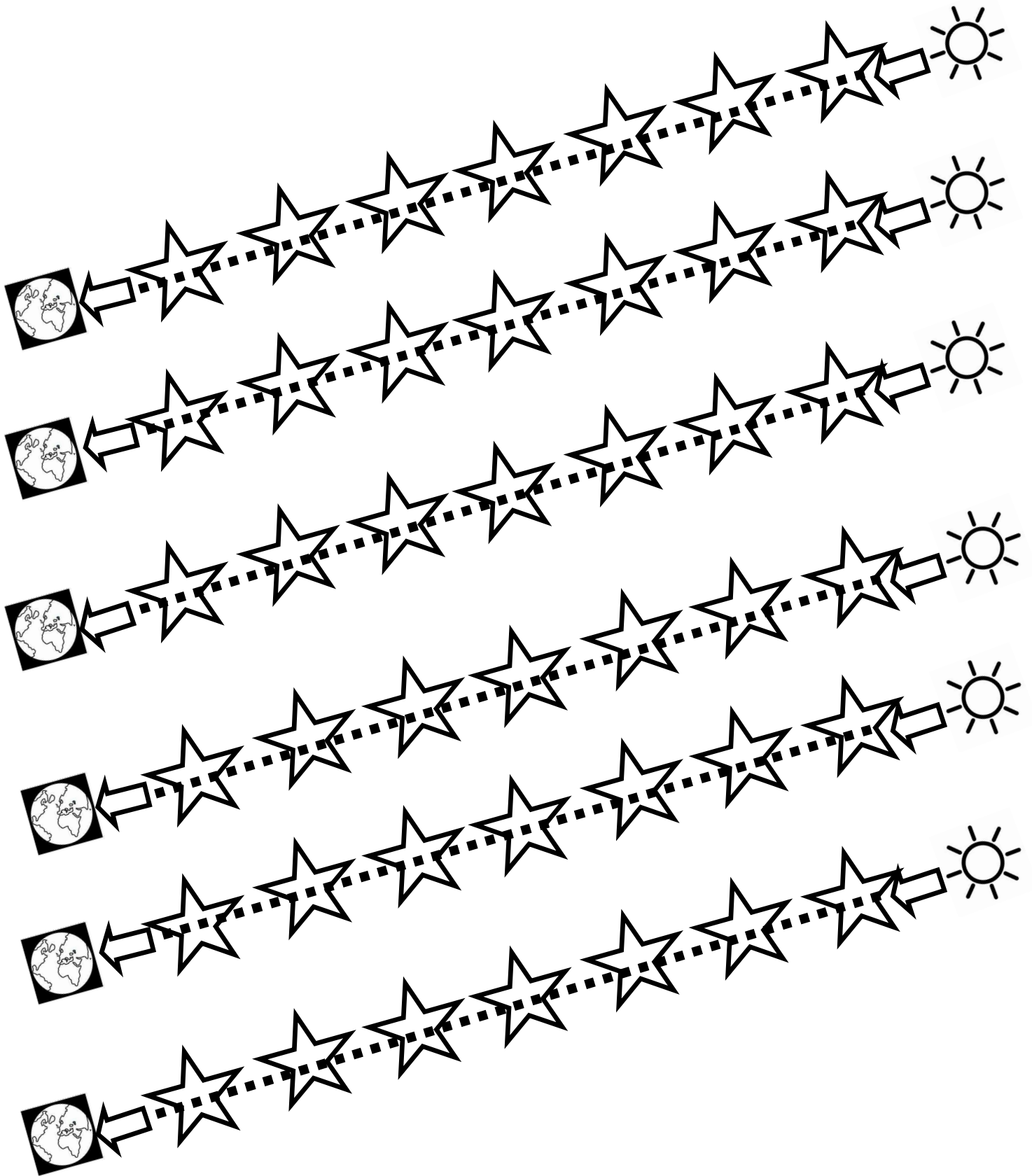

Actividades para mejorar motricidad fina

Sigue con tu lápiz las estrellitas para ir desde el sol a la tierra

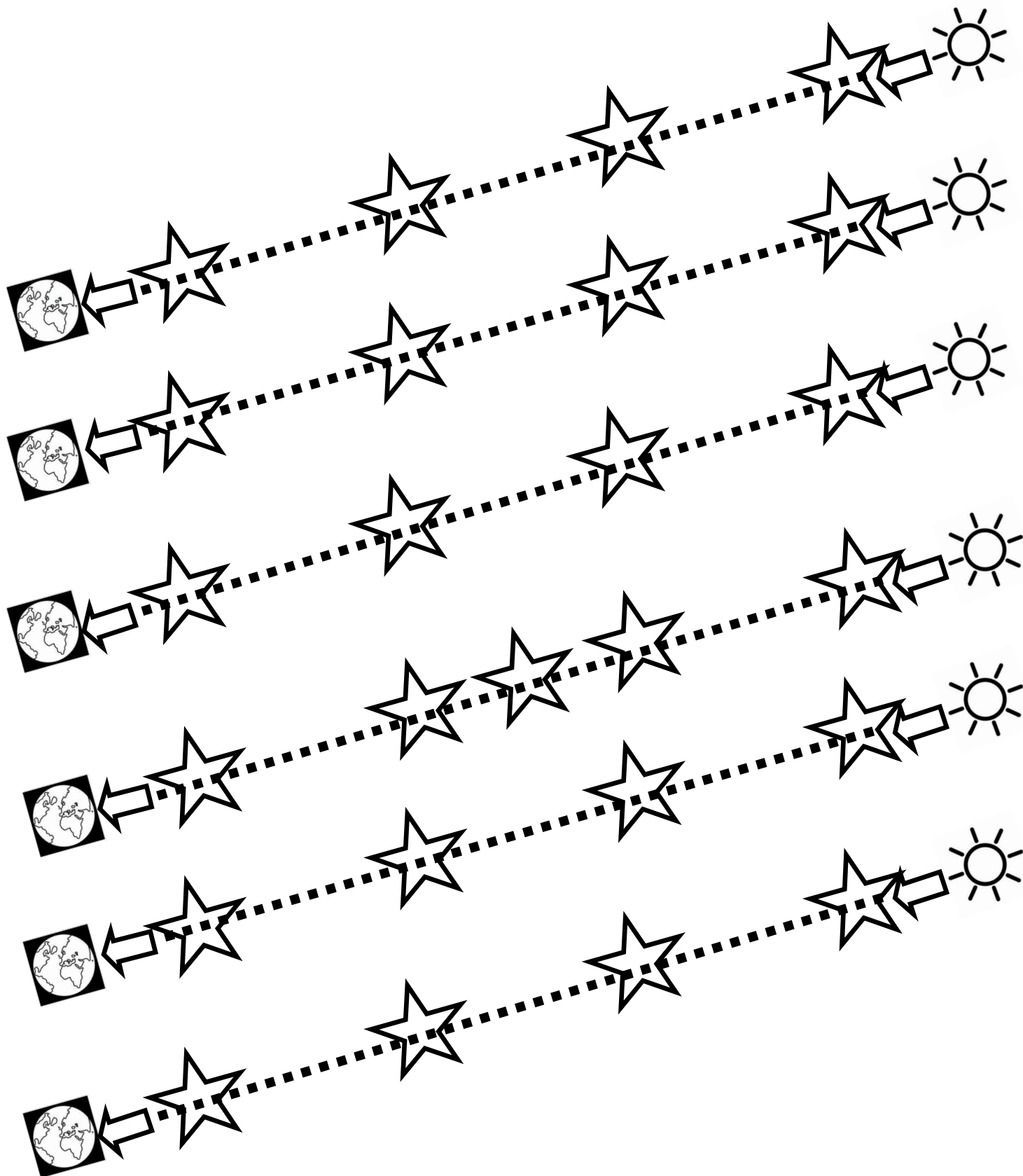

Actividades para mejorar motricidad fina

Sigue con tu lápiz las estrellitas para ir desde el sol a la tierra

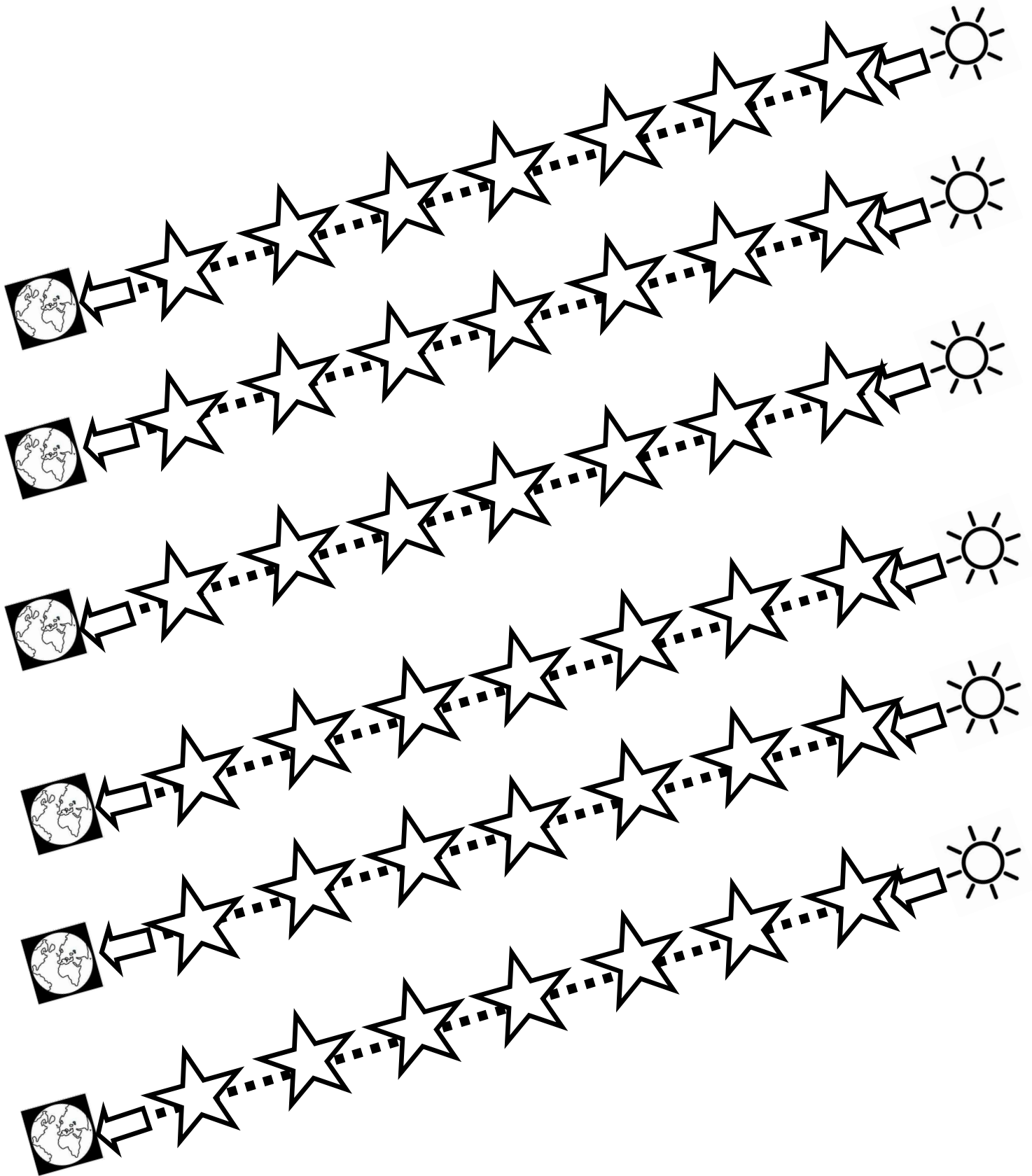

Actividades para mejorar motricidad fina

Sigue con tu lápiz las estrellitas para ir desde el sol a la tierra

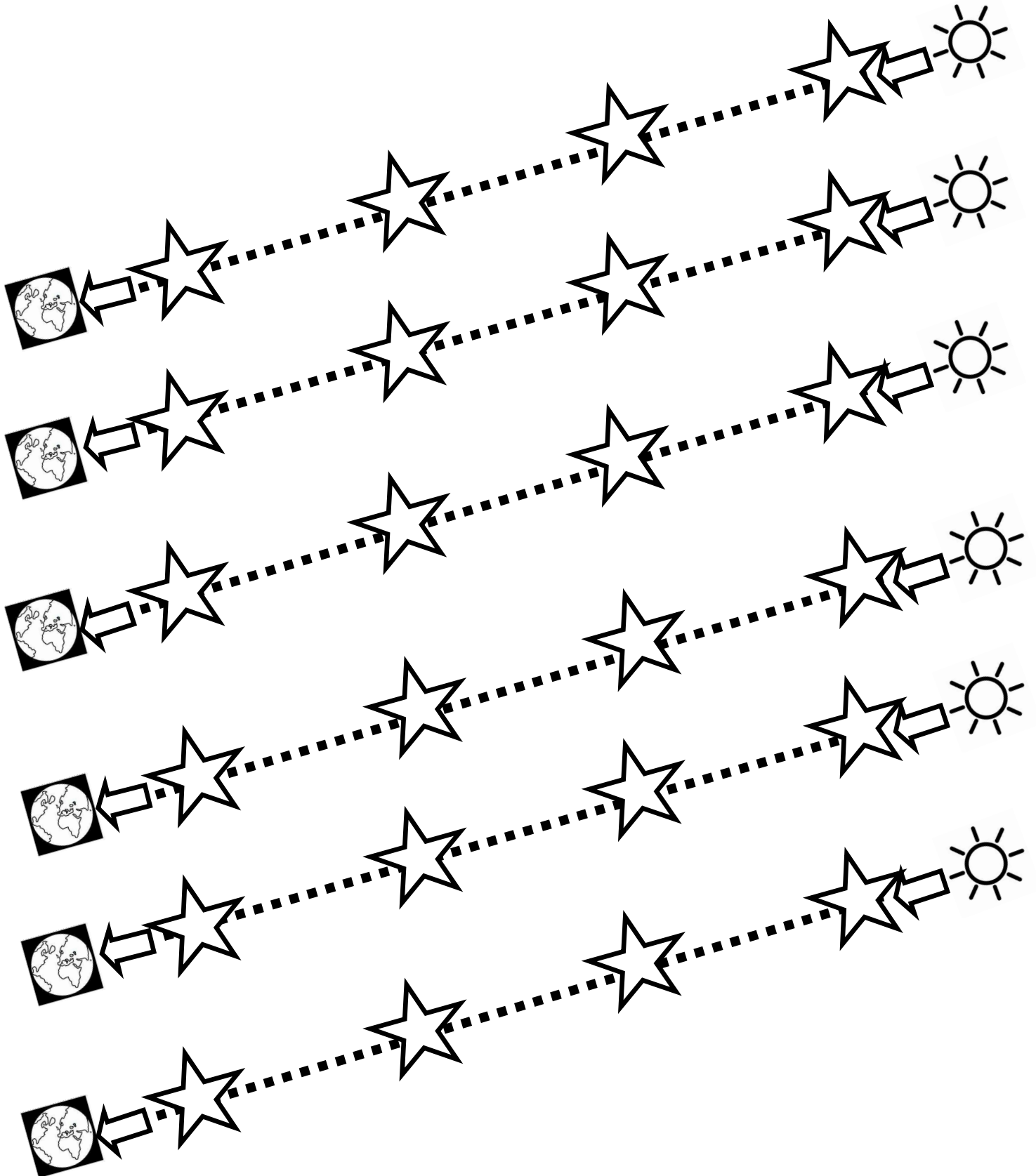

Actividades para mejorar motricidad fina

Sigue con tu lápiz las estrellitas para ir desde el sol a la tierra

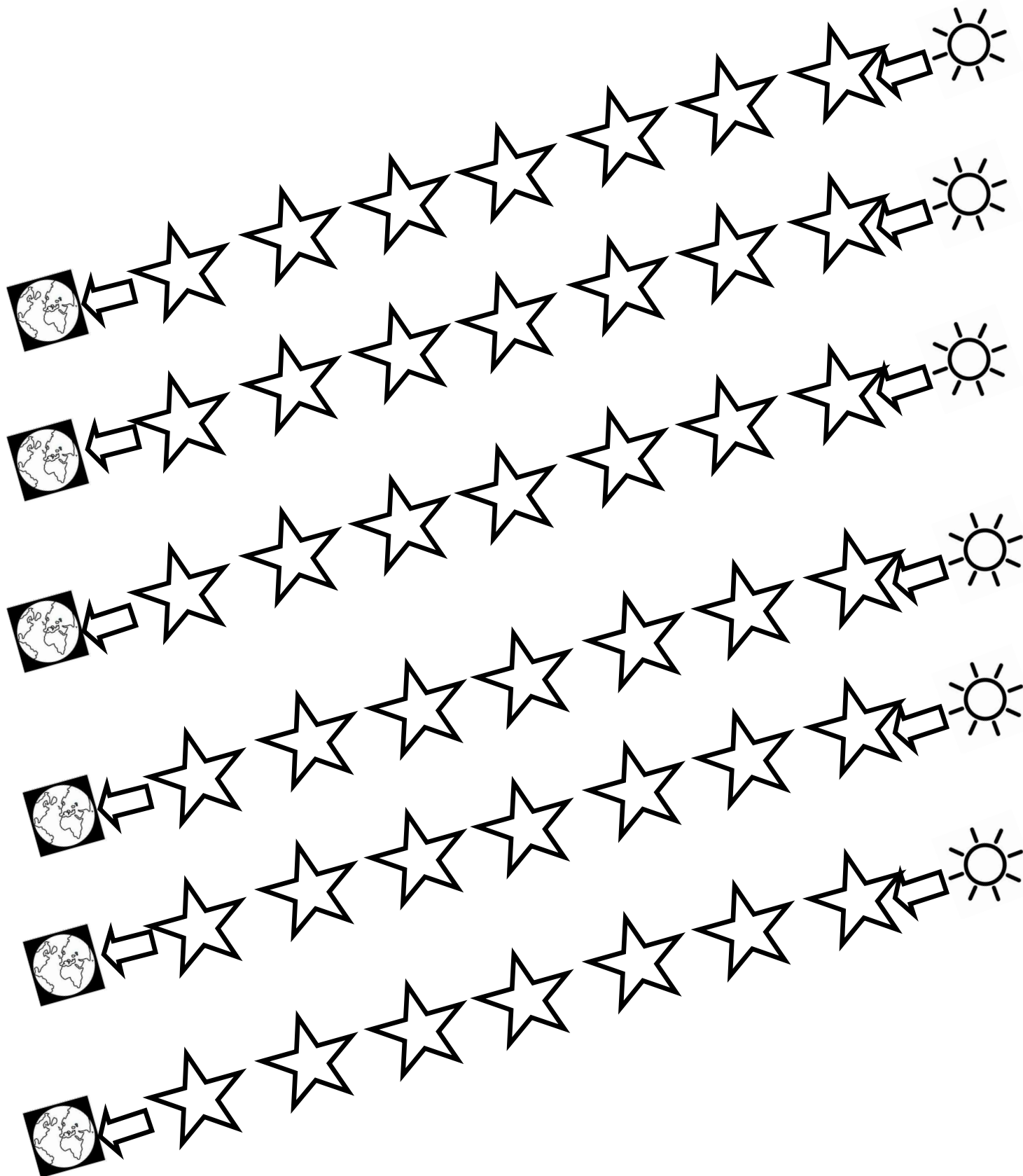

Actividades para mejorar motricidad fina

Sigue con tu lápiz las estrellitas para ir desde el sol a la tierra



Actividades para mejorar motricidad fina

Sigue con tu lápiz los corazones para unir a la mama y a su bebe

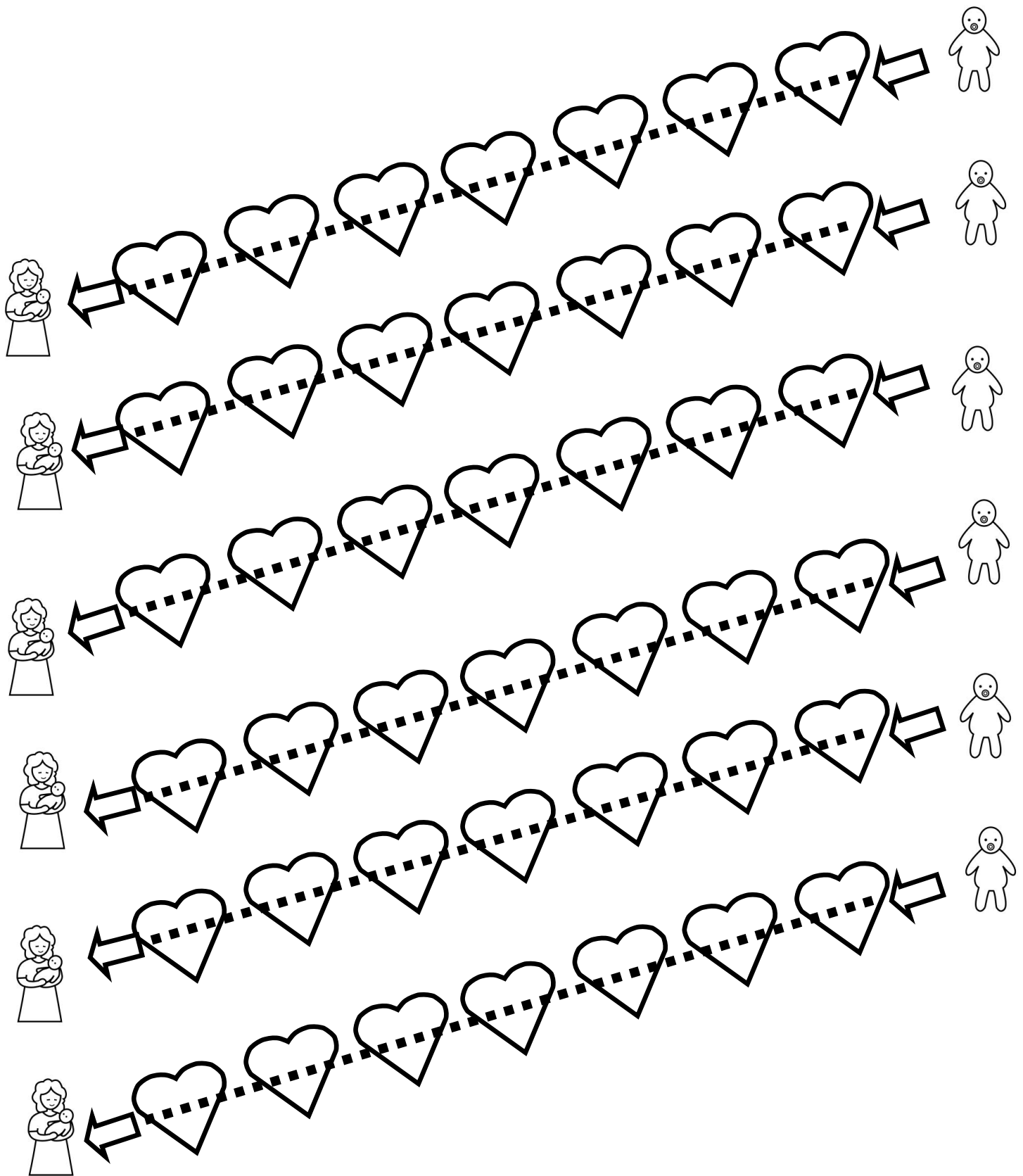

Actividades para mejorar motricidad fina

Sigue con tu lápiz los corazones para unir a la mama y a su bebe

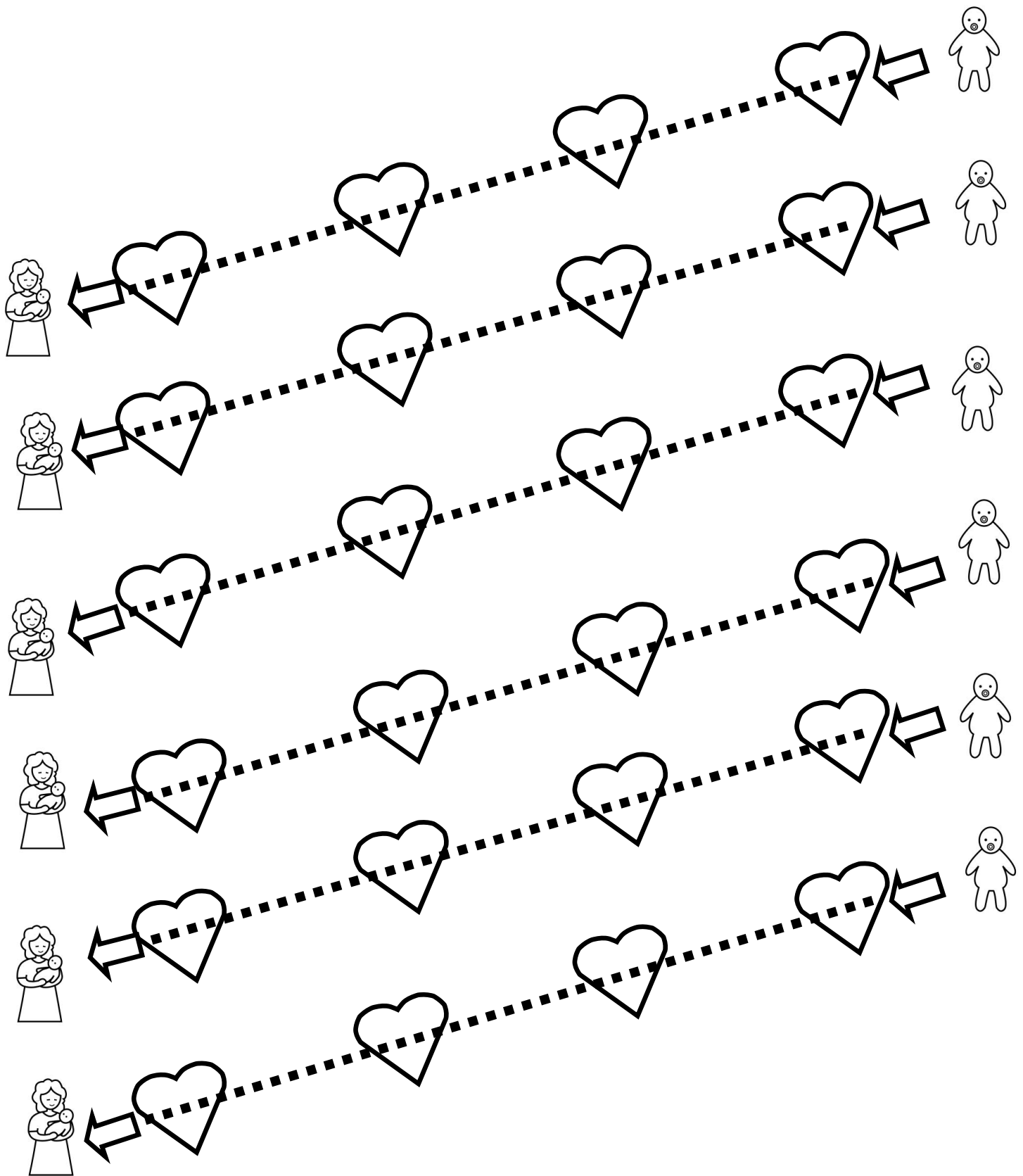

Actividades para mejorar motricidad fina

Sigue con tu lápiz los corazones para unir a la mama y a su bebe

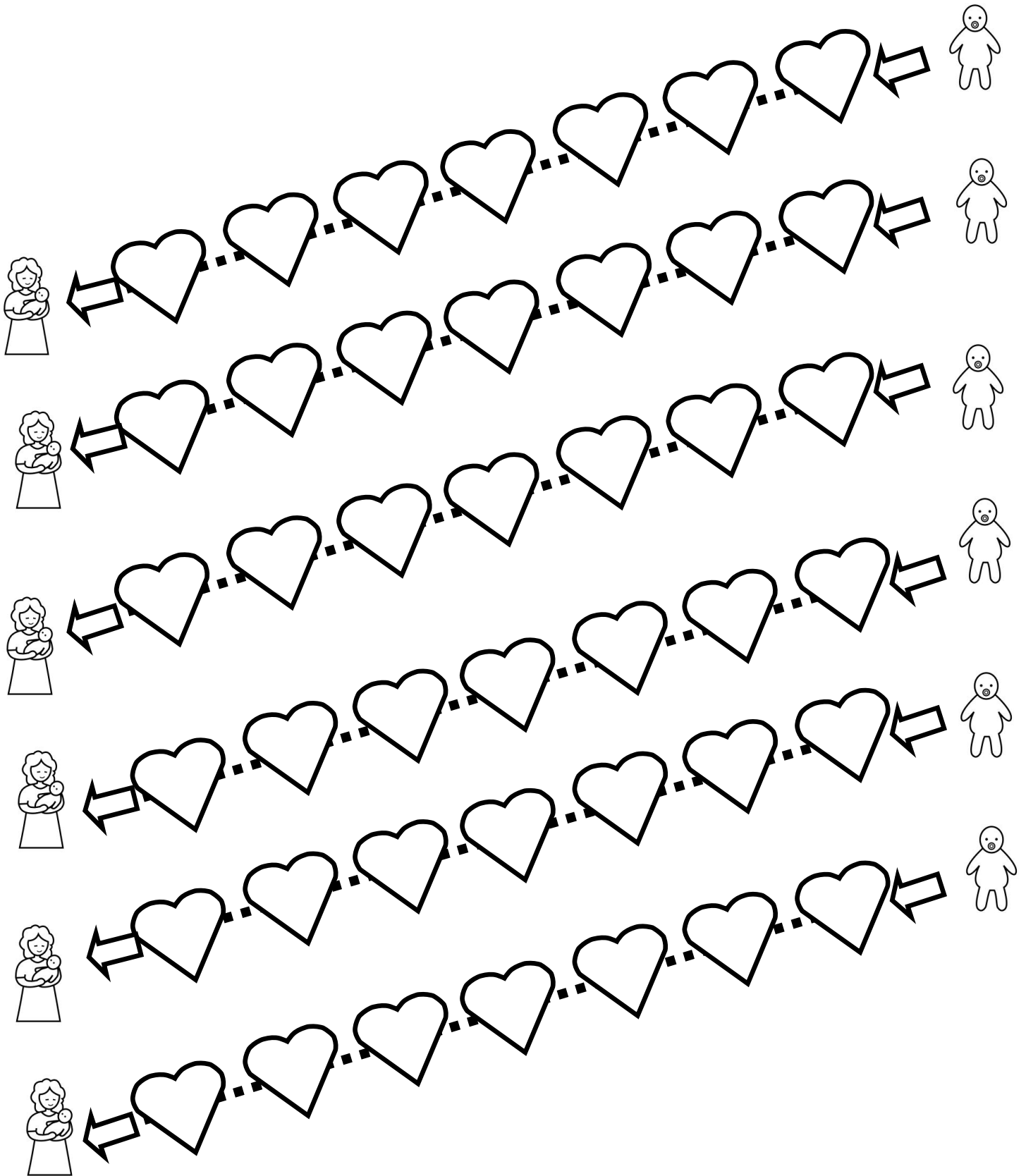

Actividades para mejorar motricidad fina

Sigue con tu lápiz los corazones para unir a la mama y a su bebe

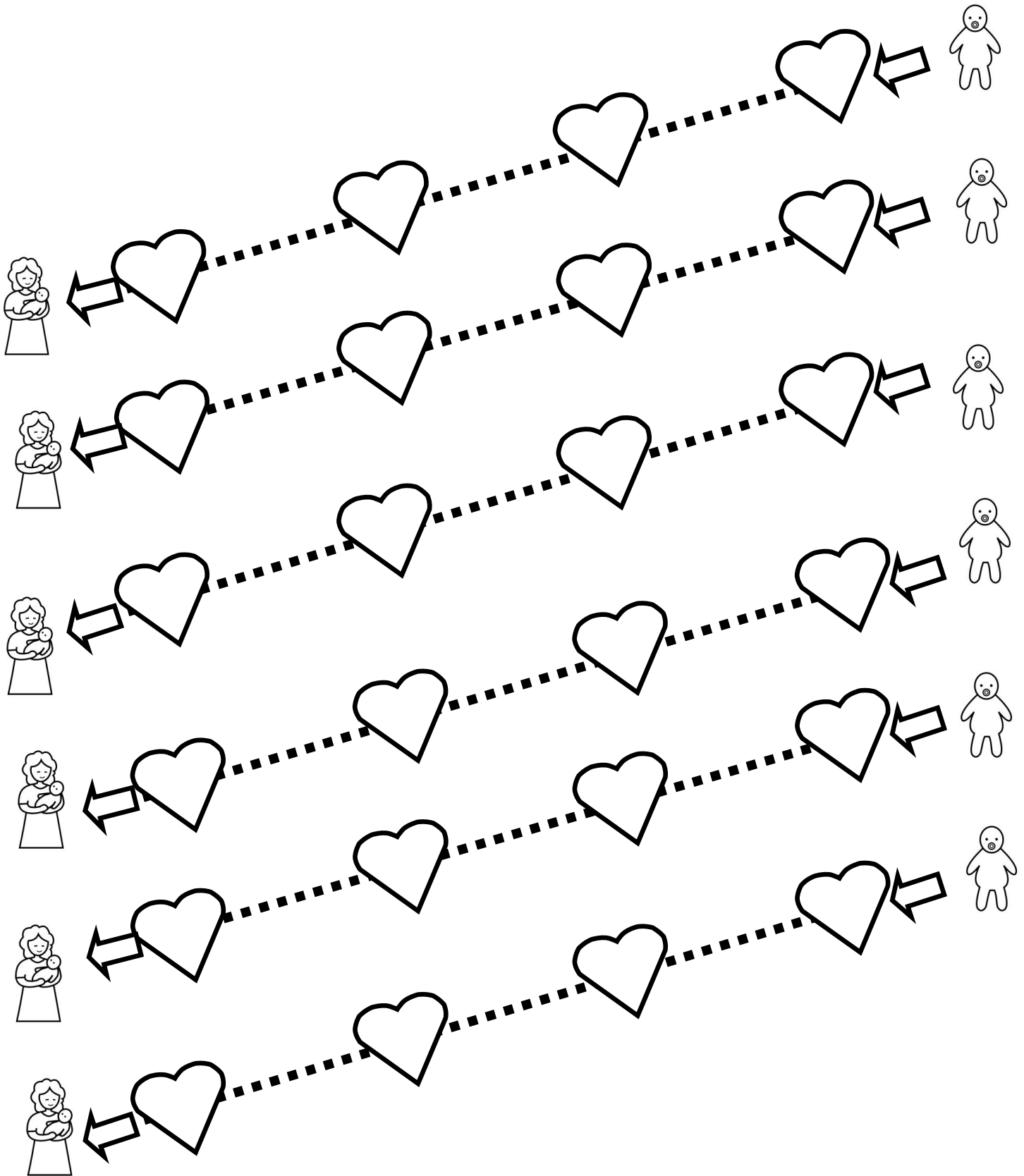

Actividades para mejorar motricidad fina

Sigue con tu lápiz los corazones para unir a la mama y a su bebe

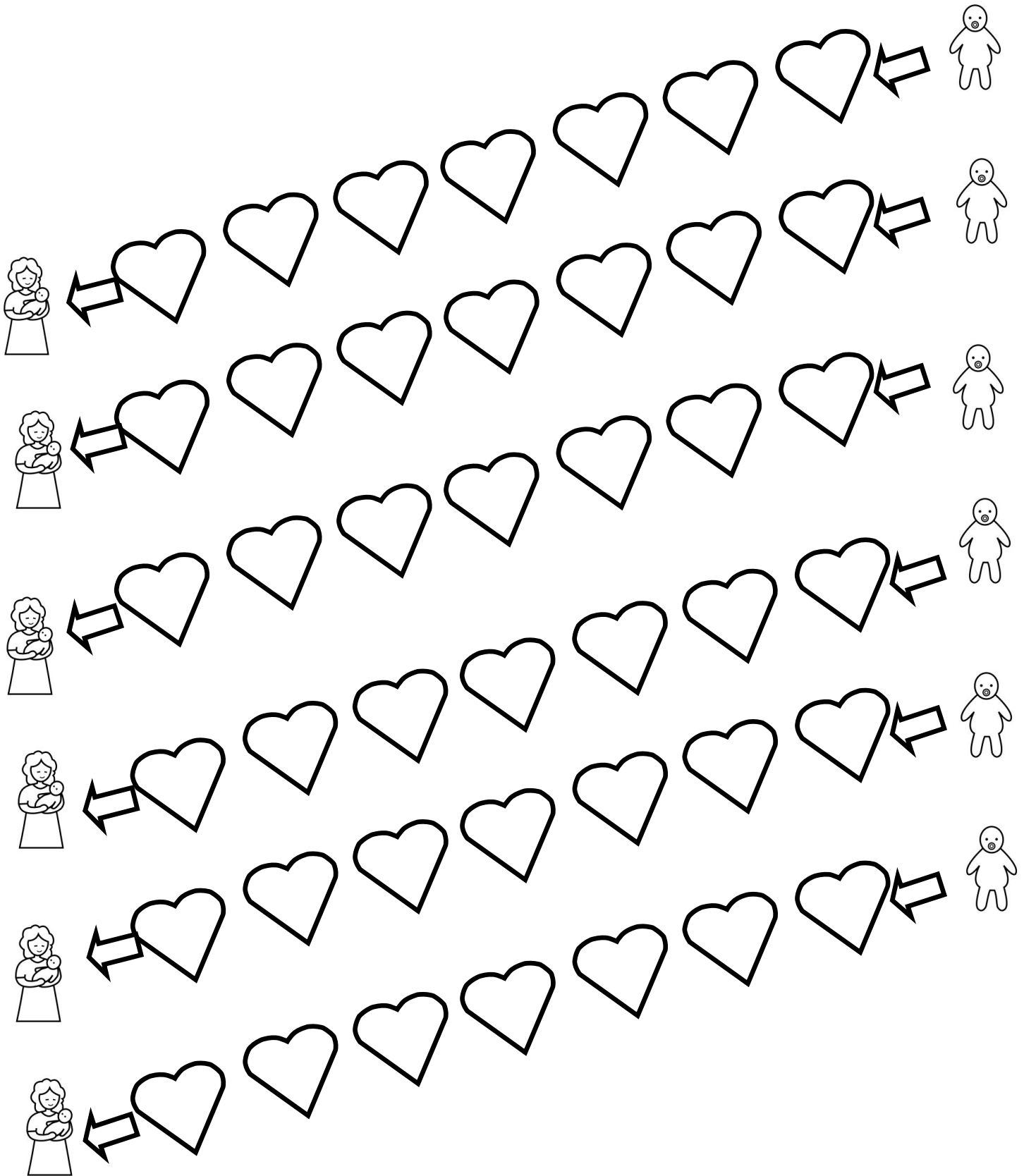

Actividades para mejorar motricidad fina

Sigue con tu lápiz los corazones para unir a la mama y a su bebe

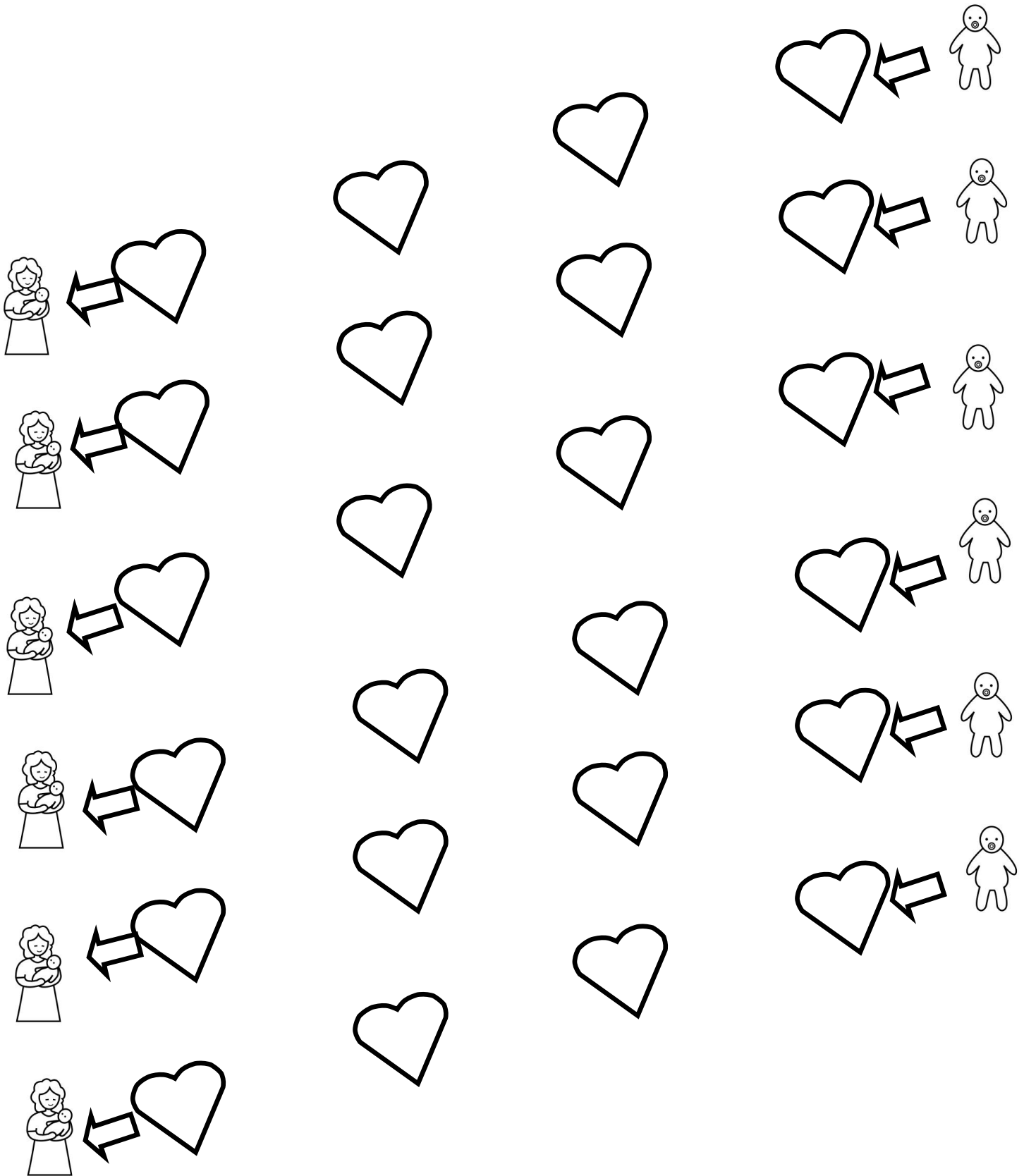

Actividades para mejorar motricidad fina

Sigue con tu lápiz las caras para unir al niño con su amiga

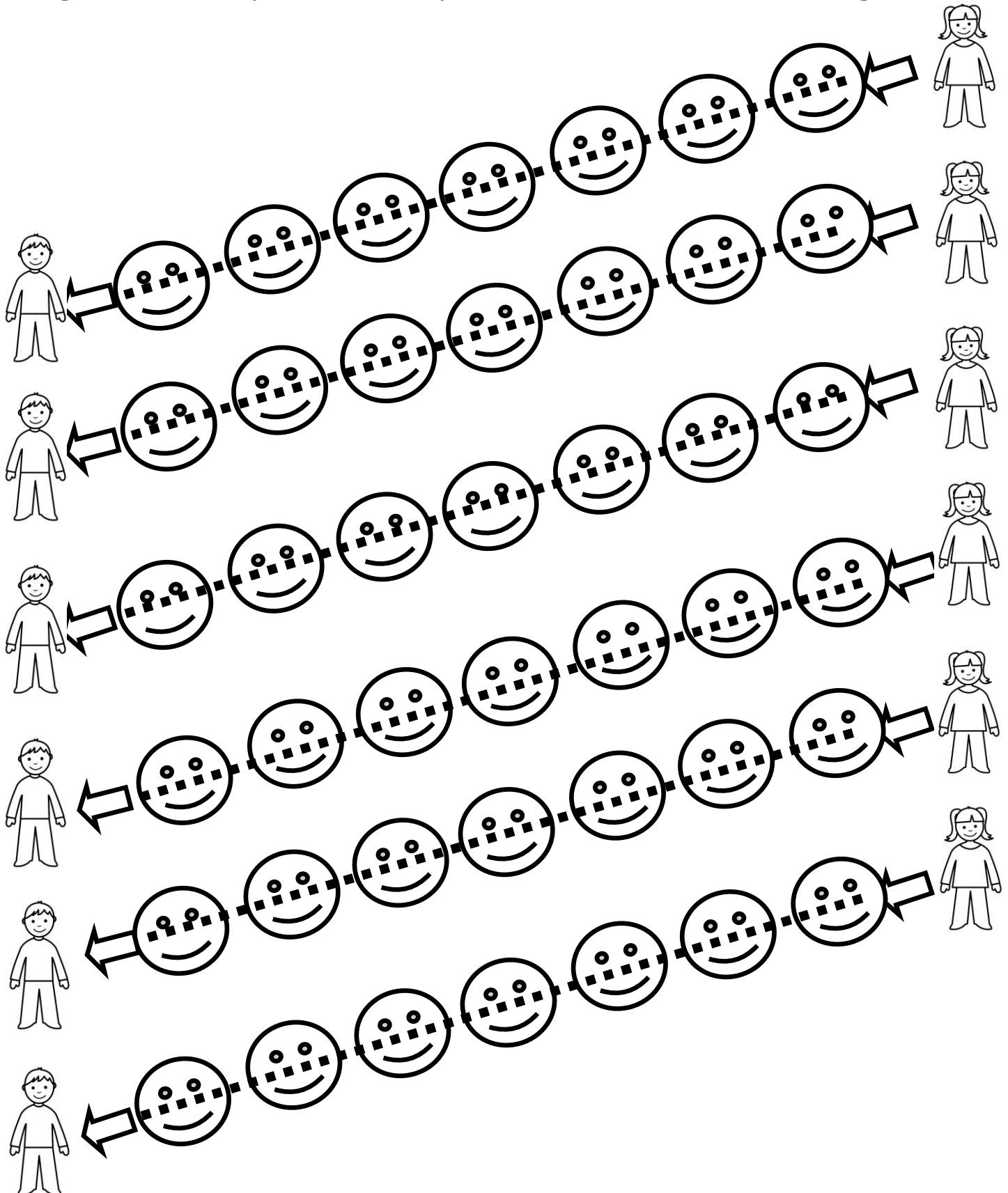

Actividades para mejorar motricidad fina

Sigue con tu lápiz las caras para unir al niño con su amiga

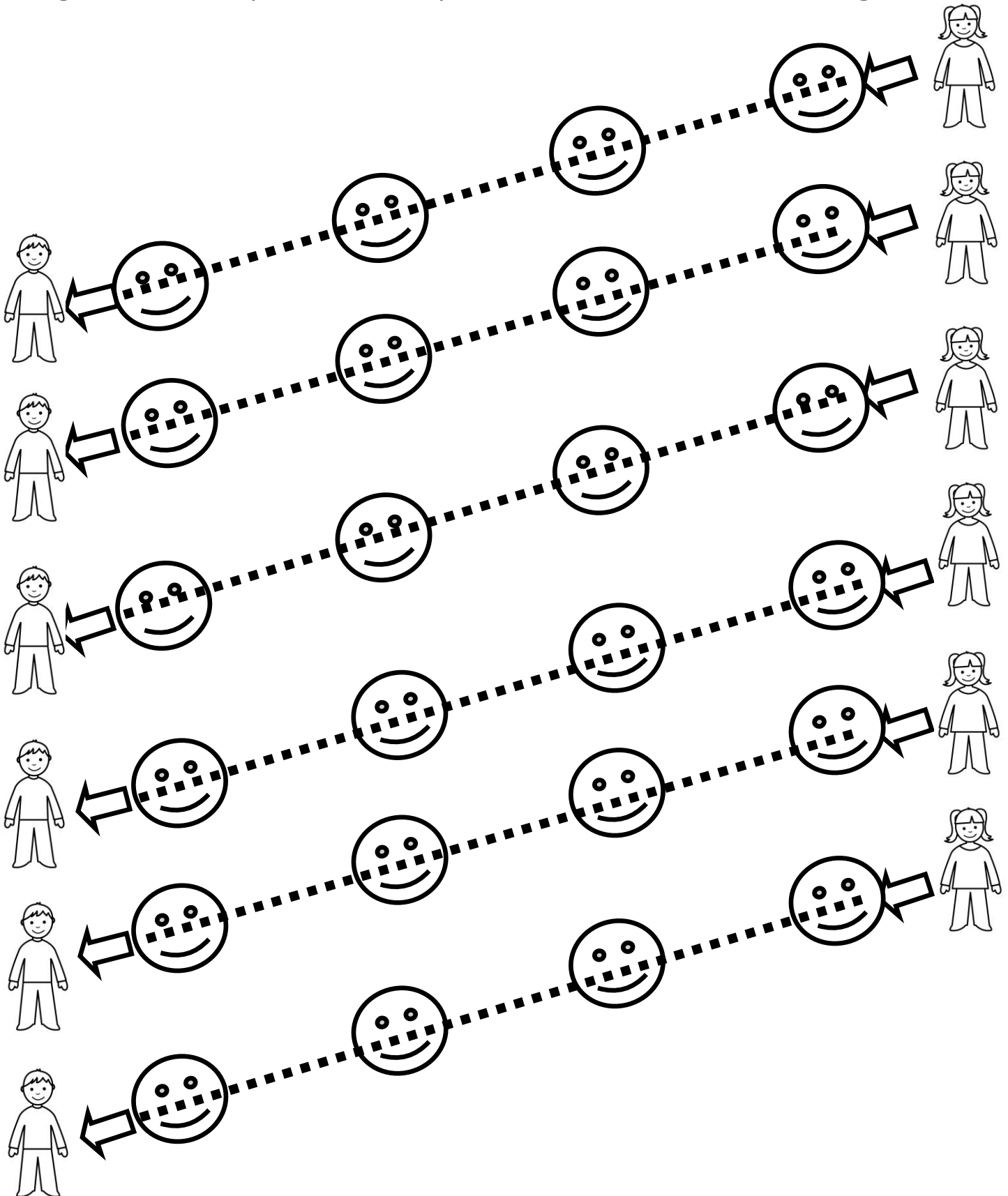

Actividades para mejorar motricidad fina

Sigue con tu lápiz las caras para unir al niño con su amiga

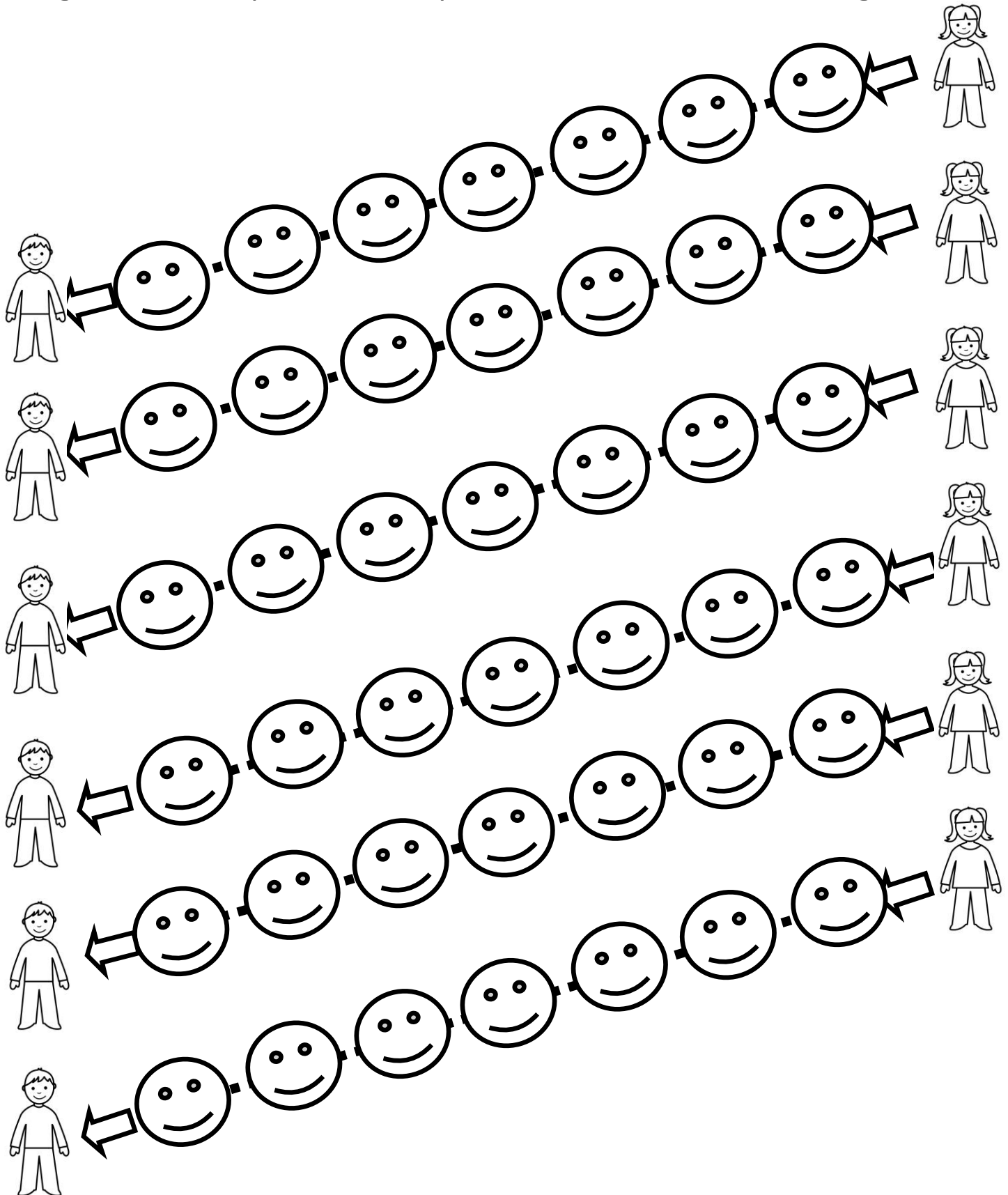

Actividades para mejorar motricidad fina

Sigue con tu lápiz las caras para unir al niño con su amiga

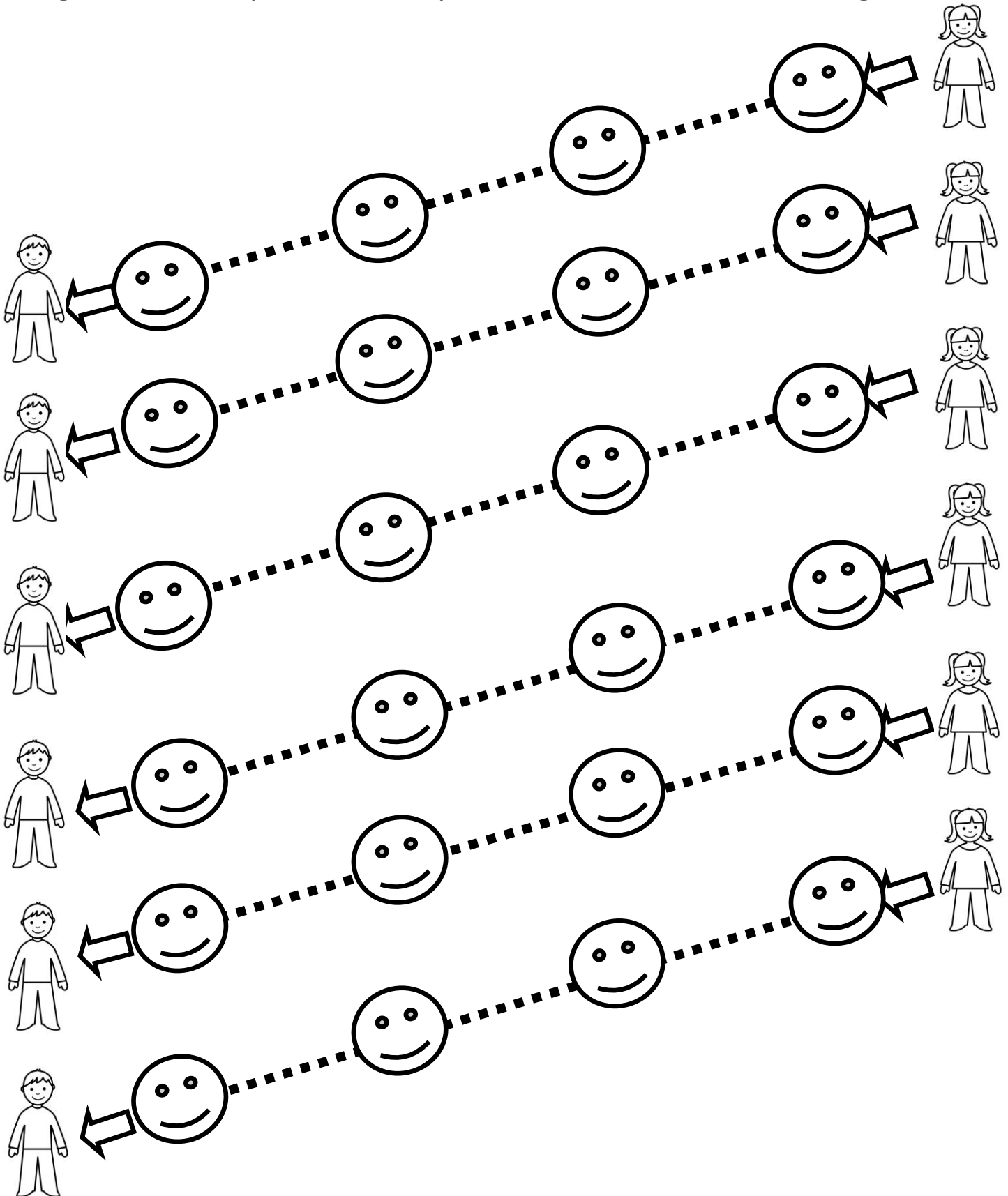

Actividades para mejorar motricidad fina

Sigue con tu lápiz las caras para unir al niño con su amiga

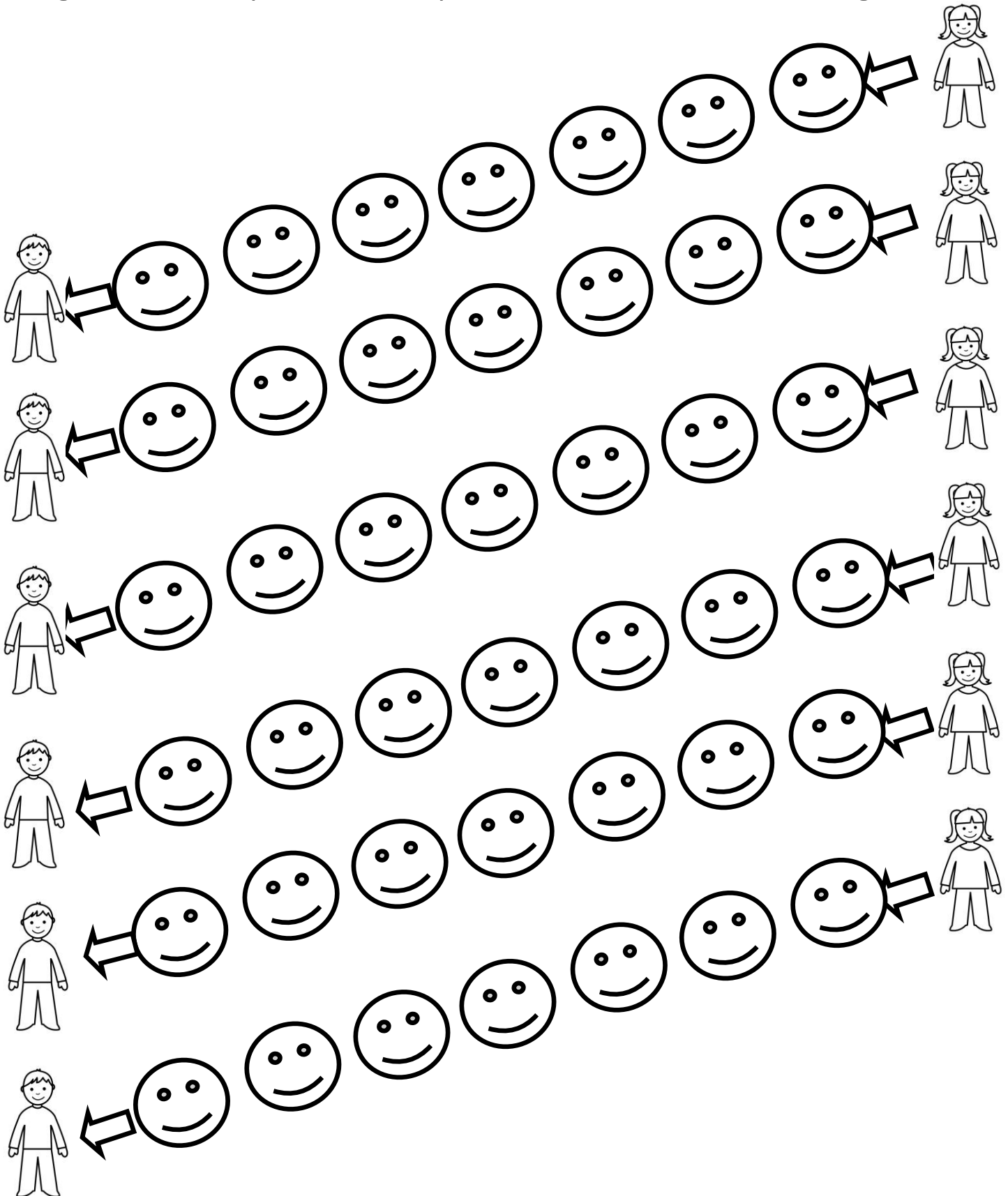

Actividades para mejorar motricidad fina

Sigue con tu lápiz las caras para unir al niño con su amiga

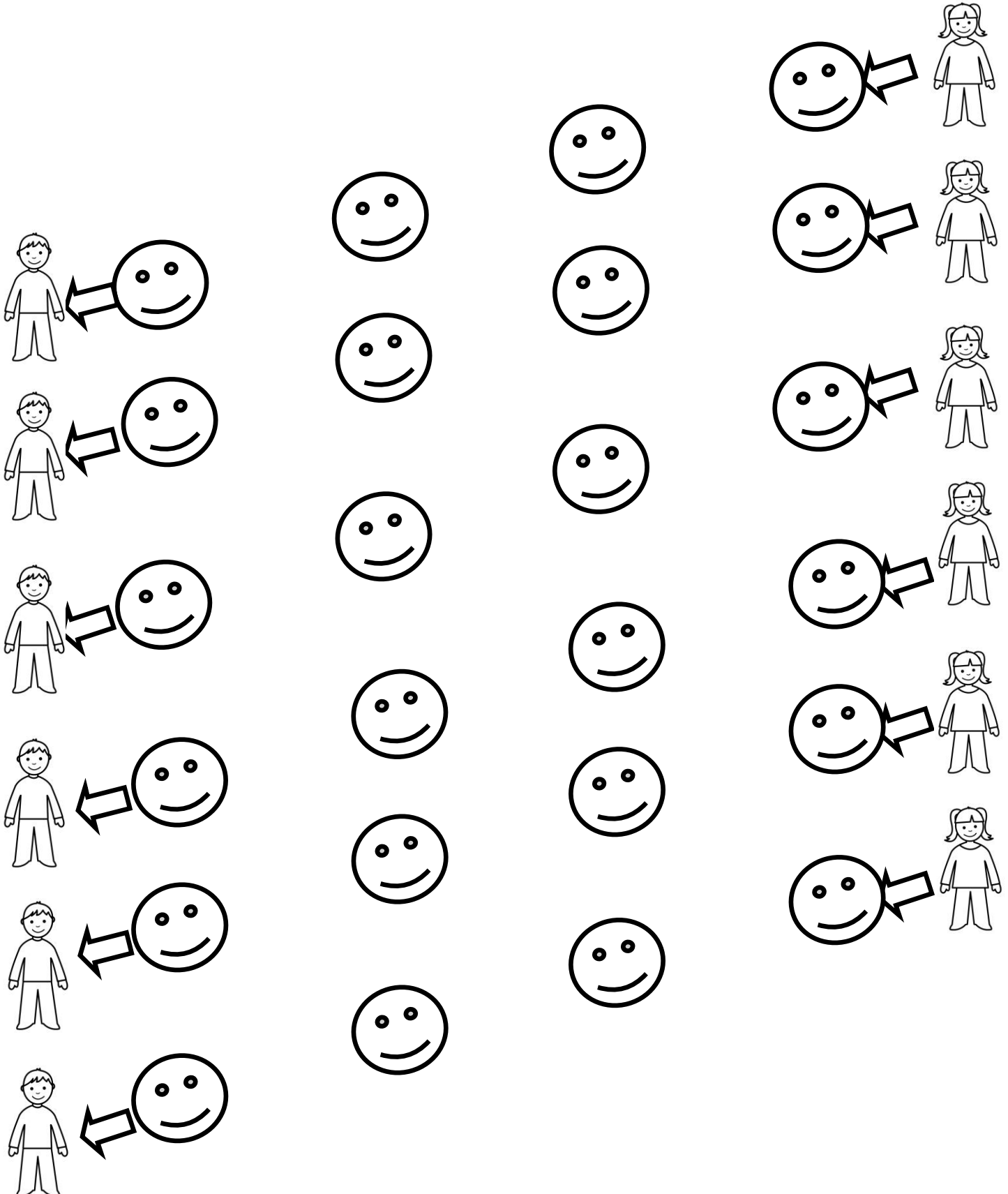

Actividades para mejorar motricidad fina

Sigue con tu lápiz los círculos para unir al niño con su pelota

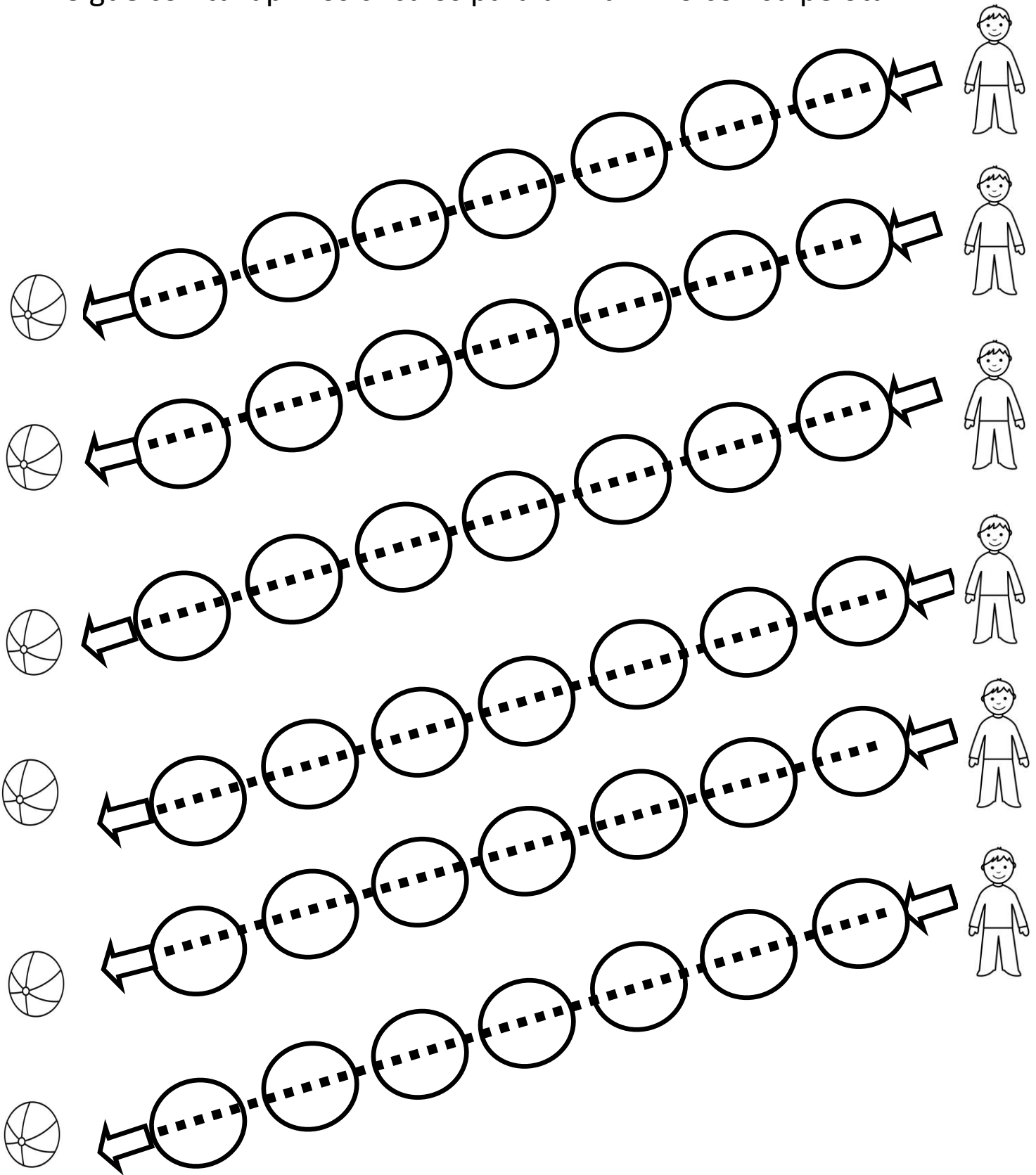

Actividades para mejorar motricidad fina

Sigue con tu lápiz los círculos para unir al niño con su pelota

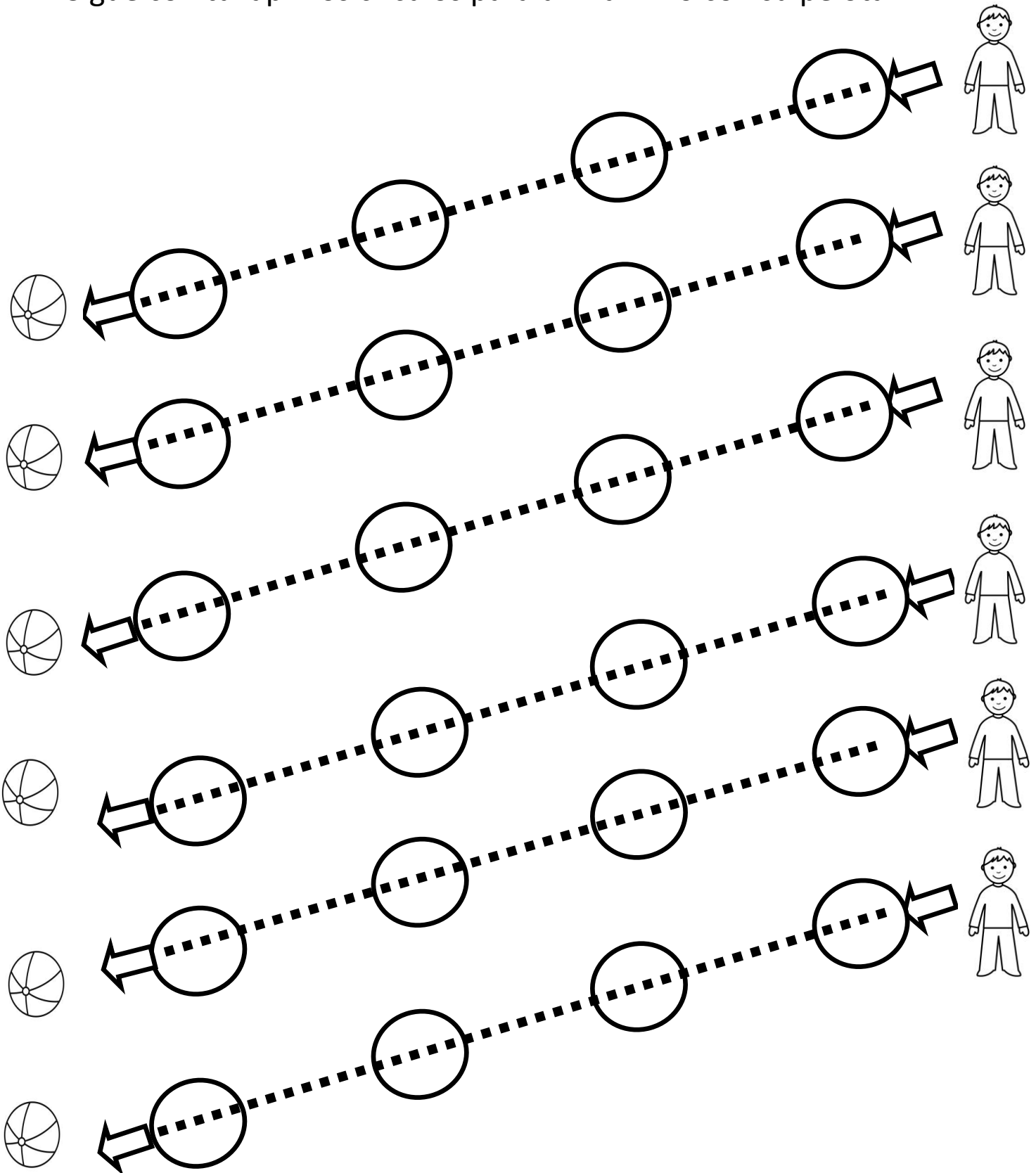

Actividades para mejorar motricidad fina

Sigue con tu lápiz los círculos para unir al niño con su pelota

The image shows a worksheet with seven rows of a zigzag path of circles. Each row starts with a ball on the left and ends with a boy on the right. The path consists of circles connected by small squares, with arrows indicating the direction of the path. The path starts with a ball on the left and ends with a boy on the right.

Actividades para mejorar motricidad fina

Sigue con tu lápiz los círculos para unir al niño con su pelota

The worksheet contains eight rows of tracing exercises. Each row consists of a sequence of circles connected by dashed lines, sloping downwards from right to left. The first circle in each row has a thick arrow pointing towards the ball on the left. To the right of each row is a simple line drawing of a boy. The goal is to trace the dashed lines from the boy to the ball.

Actividades para mejorar motricidad fina

Sigue con tu lápiz los círculos para unir al niño con su pelota

Actividades para mejorar motricidad fina

Sigue con tu lápiz los círculos para unir al niño con su pelota

The activity consists of a grid of circles and arrows. The first column contains a ball icon followed by an arrow pointing left to a circle. The second column contains seven empty circles. The third column contains seven empty circles. The fourth column contains a circle with an arrow pointing left to a boy icon. The fifth column contains seven empty circles. The sixth column contains seven empty circles. The seventh column contains a circle with an arrow pointing left to a boy icon. The eighth column contains seven empty circles. The ninth column contains a circle with an arrow pointing left to a boy icon. The tenth column contains seven empty circles. The eleventh column contains a circle with an arrow pointing left to a boy icon. The twelfth column contains seven empty circles. The thirteenth column contains a circle with an arrow pointing left to a boy icon. The fourteenth column contains seven empty circles. The fifteenth column contains a circle with an arrow pointing left to a boy icon. The sixteenth column contains seven empty circles. The seventeenth column contains a circle with an arrow pointing left to a boy icon. The eighteenth column contains seven empty circles. The nineteenth column contains a circle with an arrow pointing left to a boy icon. The twentieth column contains seven empty circles. The twenty-first column contains a circle with an arrow pointing left to a boy icon. The twenty-second column contains seven empty circles. The twenty-third column contains a circle with an arrow pointing left to a boy icon. The twenty-fourth column contains seven empty circles. The twenty-fifth column contains a circle with an arrow pointing left to a boy icon. The twenty-sixth column contains seven empty circles. The twenty-seventh column contains a circle with an arrow pointing left to a boy icon. The twenty-eighth column contains seven empty circles. The twenty-ninth column contains a circle with an arrow pointing left to a boy icon. The thirtieth column contains seven empty circles. The thirty-first column contains a circle with an arrow pointing left to a boy icon. The thirty-second column contains seven empty circles. The thirty-third column contains a circle with an arrow pointing left to a boy icon. The thirty-fourth column contains seven empty circles. The thirty-fifth column contains a circle with an arrow pointing left to a boy icon. The thirty-sixth column contains seven empty circles. The thirty-seventh column contains a circle with an arrow pointing left to a boy icon. The thirty-eighth column contains seven empty circles. The thirty-ninth column contains a circle with an arrow pointing left to a boy icon. The fortieth column contains seven empty circles. The forty-first column contains a circle with an arrow pointing left to a boy icon. The forty-second column contains seven empty circles. The forty-third column contains a circle with an arrow pointing left to a boy icon. The forty-fourth column contains seven empty circles. The forty-fifth column contains a circle with an arrow pointing left to a boy icon. The forty-sixth column contains seven empty circles. The forty-seventh column contains a circle with an arrow pointing left to a boy icon. The forty-eighth column contains seven empty circles. The forty-ninth column contains a circle with an arrow pointing left to a boy icon. The fiftieth column contains seven empty circles. The fifty-first column contains a circle with an arrow pointing left to a boy icon. The fifty-second column contains seven empty circles. The fifty-third column contains a circle with an arrow pointing left to a boy icon. The fifty-fourth column contains seven empty circles. The fifty-fifth column contains a circle with an arrow pointing left to a boy icon. The fifty-sixth column contains seven empty circles. The fifty-seventh column contains a circle with an arrow pointing left to a boy icon. The fifty-eighth column contains seven empty circles. The fifty-ninth column contains a circle with an arrow pointing left to a boy icon. The sixtieth column contains seven empty circles. The sixty-first column contains a circle with an arrow pointing left to a boy icon. The sixty-second column contains seven empty circles. The sixty-third column contains a circle with an arrow pointing left to a boy icon. The sixty-fourth column contains seven empty circles. The sixty-fifth column contains a circle with an arrow pointing left to a boy icon. The sixty-sixth column contains seven empty circles. The sixty-seventh column contains a circle with an arrow pointing left to a boy icon. The sixty-eighth column contains seven empty circles. The sixty-ninth column contains a circle with an arrow pointing left to a boy icon. The seventieth column contains seven empty circles. The seventy-first column contains a circle with an arrow pointing left to a boy icon. The seventy-second column contains seven empty circles. The seventy-third column contains a circle with an arrow pointing left to a boy icon. The seventy-fourth column contains seven empty circles. The seventy-fifth column contains a circle with an arrow pointing left to a boy icon. The seventy-sixth column contains seven empty circles. The seventy-seventh column contains a circle with an arrow pointing left to a boy icon. The seventy-eighth column contains seven empty circles. The seventy-ninth column contains a circle with an arrow pointing left to a boy icon. The eightieth column contains seven empty circles. The eighty-first column contains a circle with an arrow pointing left to a boy icon. The eighty-second column contains seven empty circles. The eighty-third column contains a circle with an arrow pointing left to a boy icon. The eighty-fourth column contains seven empty circles. The eighty-fifth column contains a circle with an arrow pointing left to a boy icon. The eighty-sixth column contains seven empty circles. The eighty-seventh column contains a circle with an arrow pointing left to a boy icon. The eighty-eighth column contains seven empty circles. The eighty-ninth column contains a circle with an arrow pointing left to a boy icon. The ninetieth column contains seven empty circles. The ninety-first column contains a circle with an arrow pointing left to a boy icon. The ninety-second column contains seven empty circles. The ninety-third column contains a circle with an arrow pointing left to a boy icon. The ninety-fourth column contains seven empty circles. The ninety-fifth column contains a circle with an arrow pointing left to a boy icon. The ninety-sixth column contains seven empty circles. The ninety-seventh column contains a circle with an arrow pointing left to a boy icon. The ninety-eighth column contains seven empty circles. The ninety-ninth column contains a circle with an arrow pointing left to a boy icon. The hundredth column contains seven empty circles.

Actividades para mejorar motricidad fina

Sigue con tu lápiz los cuadrados para unir a la niña con su casa

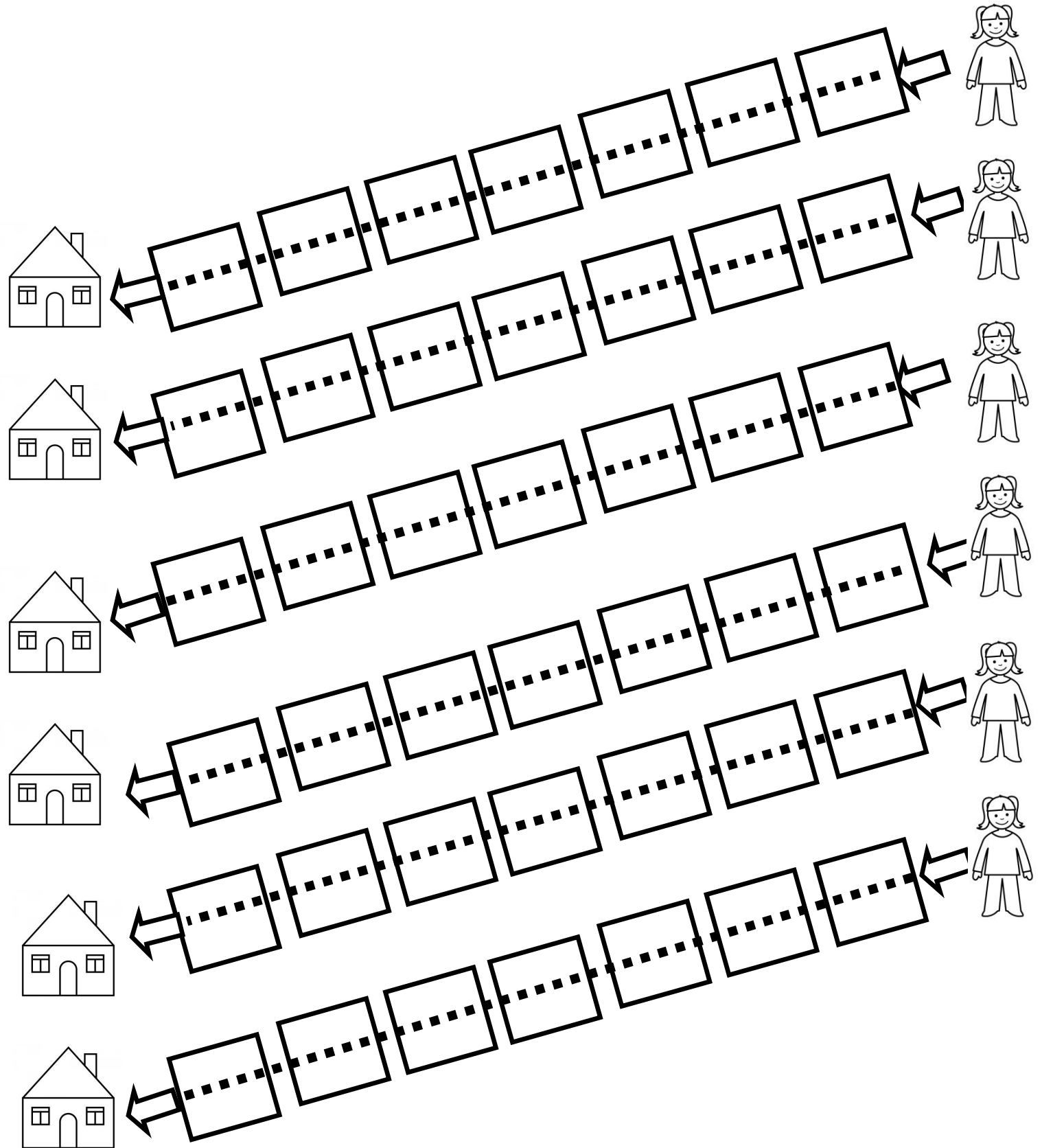

Actividades para mejorar motricidad fina

Sigue con tu lápiz los cuadrados para unir a la niña con su casa

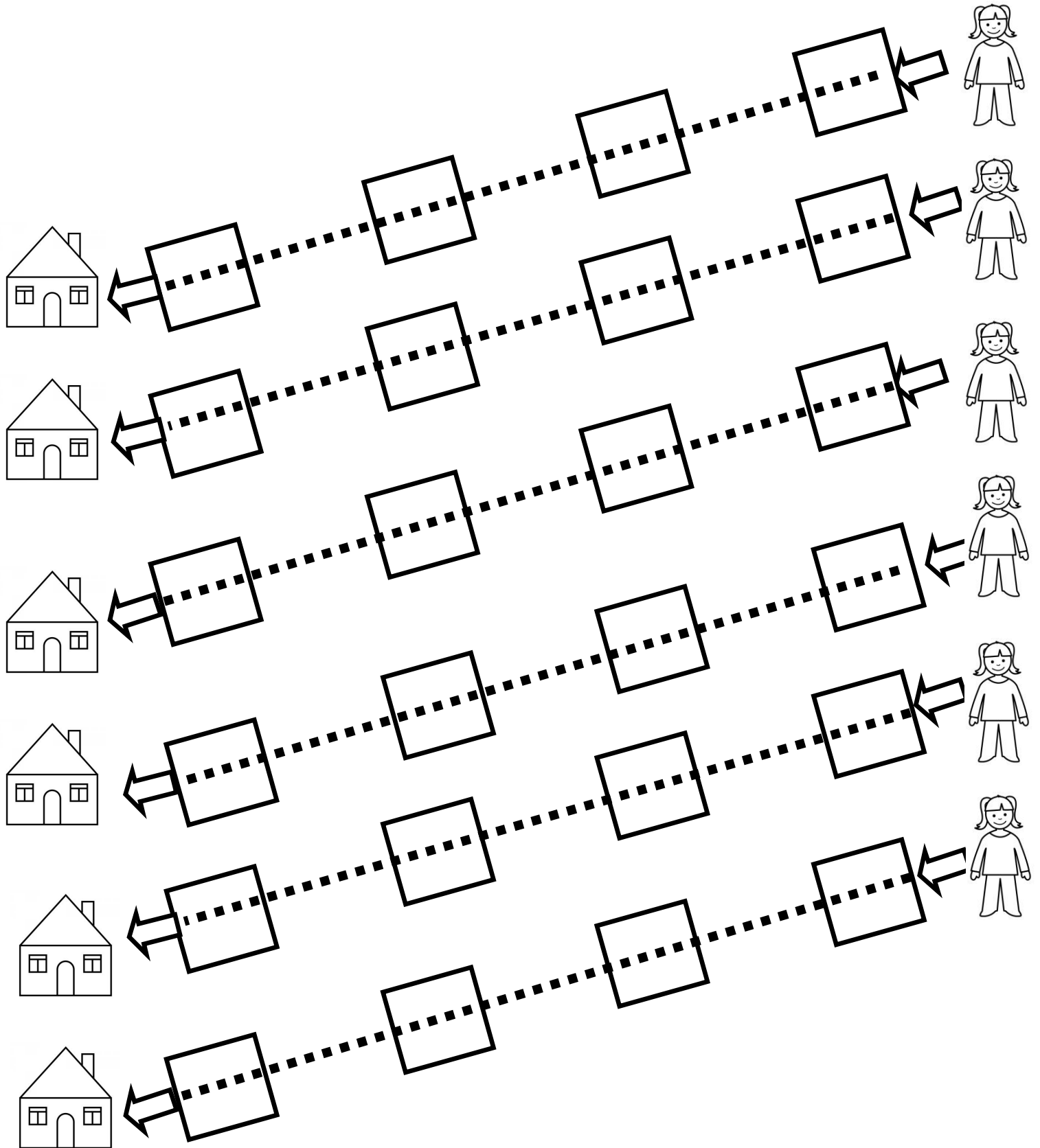

Actividades para mejorar motricidad fina

Sigue con tu lápiz los cuadrados para unir a la niña con su casa

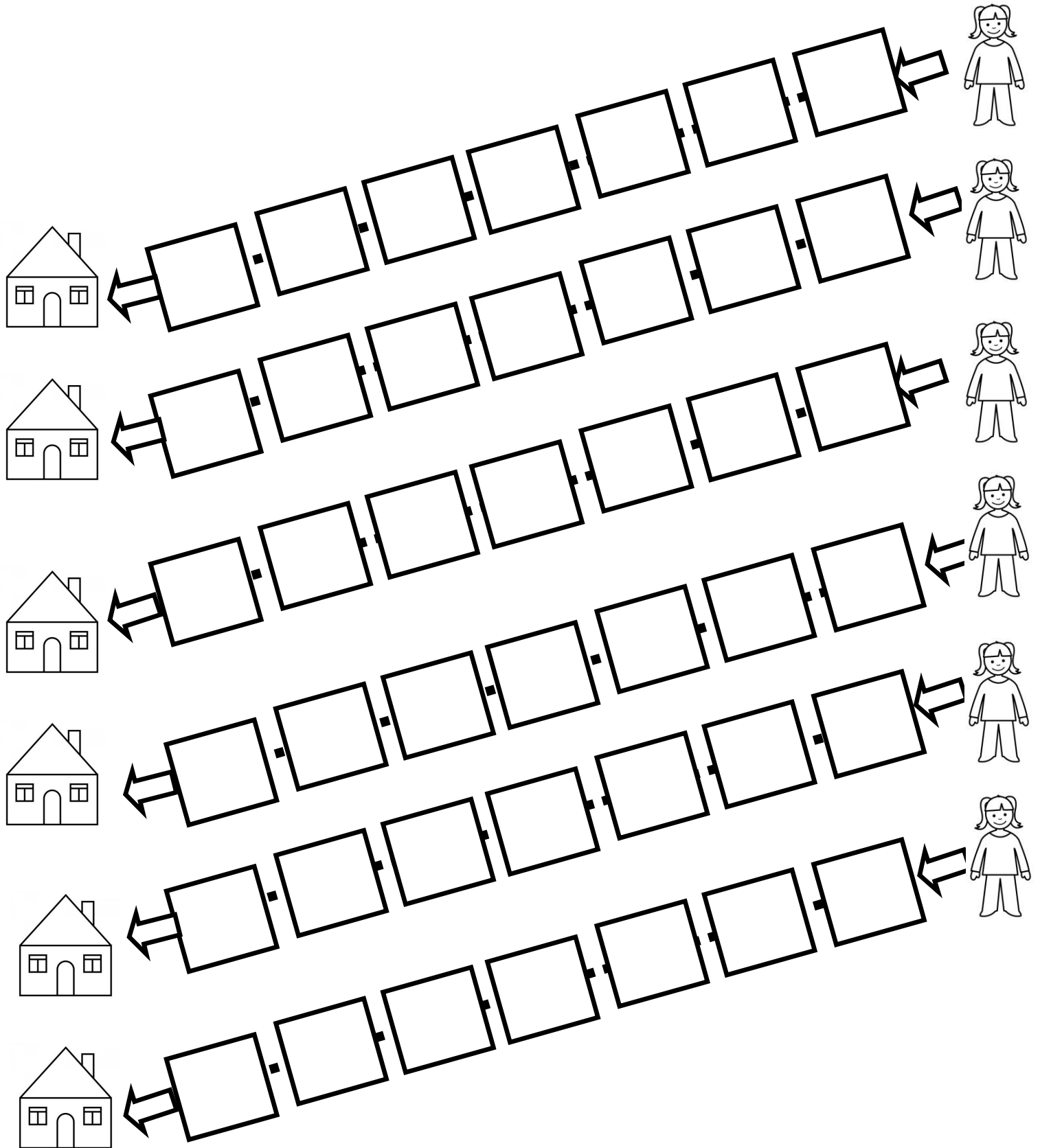

Actividades para mejorar motricidad fina

Sigue con tu lápiz los cuadrados para unir a la niña con su casa

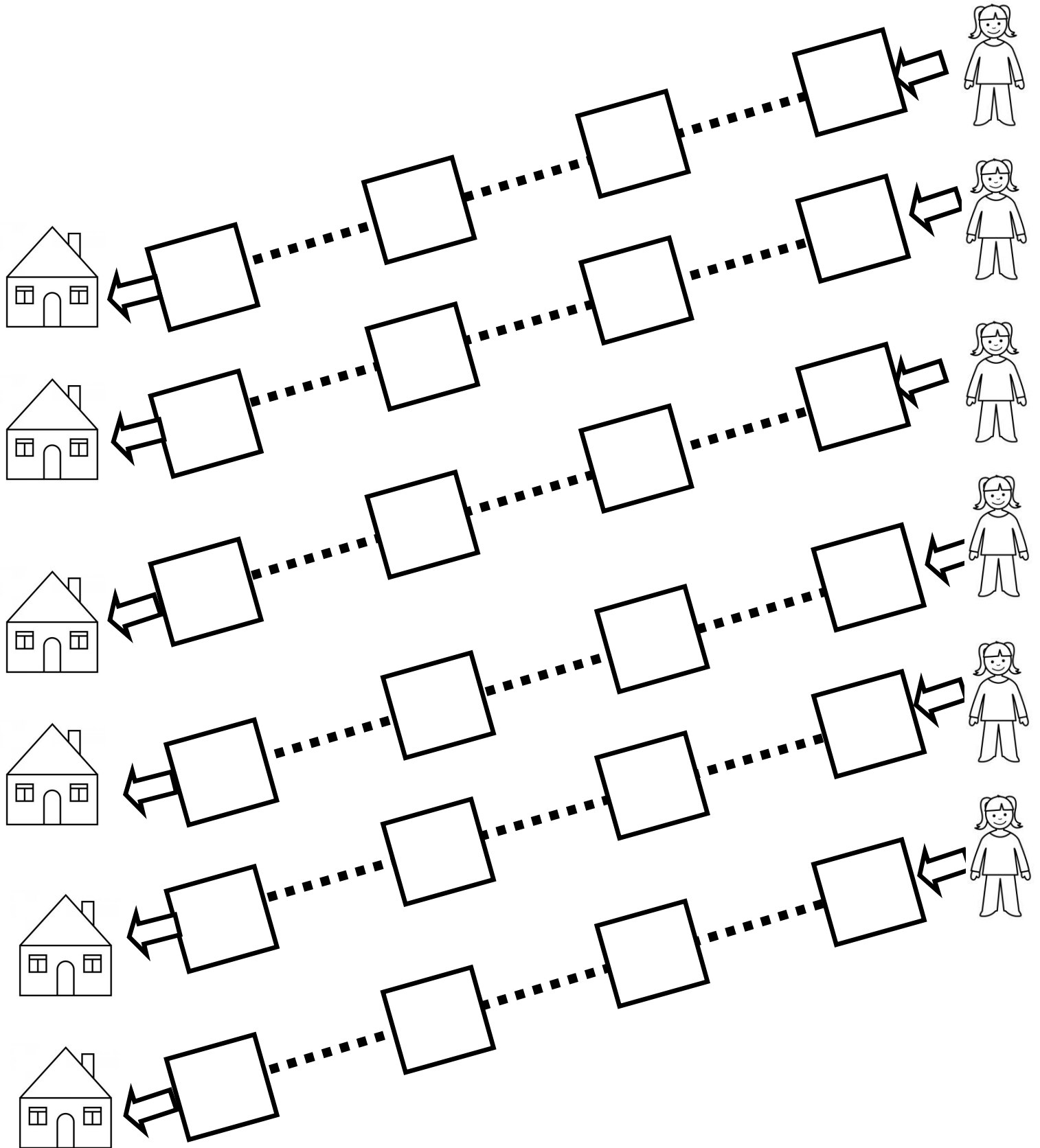

Actividades para mejorar motricidad fina

Sigue con tu lápiz los cuadrados para unir a la niña con su casa

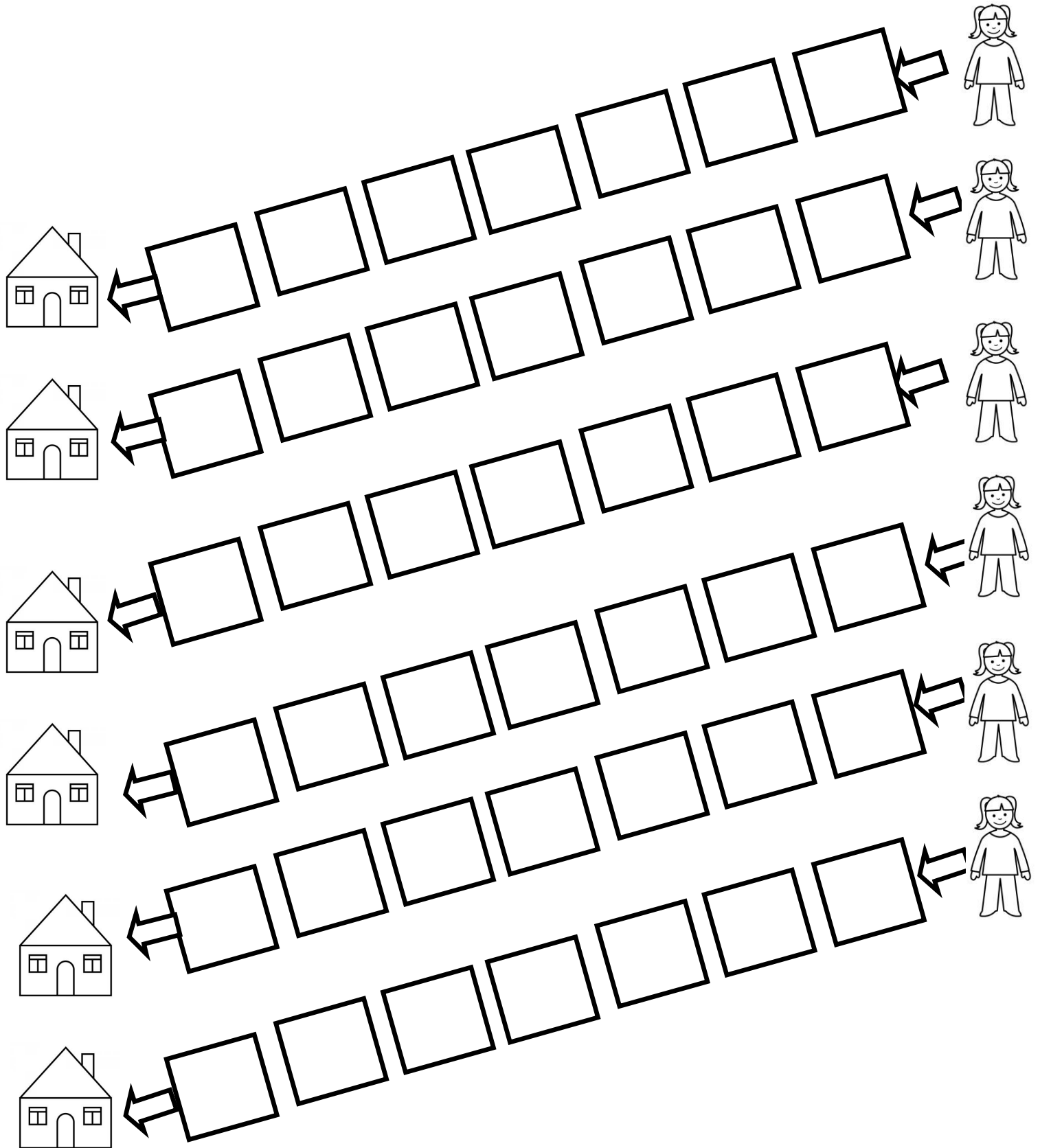

Actividades para mejorar motricidad fina

Sigue con tu lápiz los cuadrados para unir a la niña con su casa

