

LECTOESCRITURA MÉTODO GLOBAL Cuadernillo 5

h, v, y, x, w, r, rr

Autores: Belén Caro, Natalia Cortés, Lourdes García, Cristina González y
José Antonio Mora

Los pictogramas utilizados son obra de [Sergio Palao](#) para [CATEDU](#) (<http://catedu.es/arasaac/>)
publicados bajo licencia [Creative Commons](#).

Blog: cortesOalba.blogspot.com.es

(HABLA-M)

El método de lectoescritura global HABLA-M no es un método formal, sino más bien un método creado a partir del estilo de aprendizaje y las preferencias de uno de mis alumnos. He seguido el orden que provocaba en el niño un aprendizaje más funcional y significativo.

Por lo tanto, es posible que este método sea objeto de alguna crítica de expertos o expertas en métodos globales. No pretendo que este trabajo siga las características puras de un método de lectoescritura global, solo que siga las características puras de mi alumno.

Espero que pueda servir a algún compañero o compañera de algún colegio que, al igual que a mí, le guste compartir materiales creados a partir del conocimiento de nuestro alumnado.

¿QUÉ PASOS HE SEGUIDO? Es necesario que el niño domine el primer paso para pasar al siguiente y así sucesivamente.

1º **¿QUÉ LETRA VAMOS A TRABAJAR?** Primero trabajamos la letra, su forma y su trazo.

2º **PALABRAS QUE CONTIENE LA LETRA QUE VAMOS A TRABAJAR.** Le presentamos al niño una serie de imágenes/palabras y rodeamos la letra que vamos a trabajar. Habrá palabras con la letra a trabajar en distintas sílabas y en distintas posiciones, inicial, medial y final.

3º **FRASES ORDENADAS CON IMÁGENES A NIVEL SOLO ORAL.** Las palabras contendrán la letra que queramos trabajar. Contamos cuántas palabras tiene la frase.

4º **LEEMOS LAS FRASES SIN APENAS APOYO VISUAL Y ELEGIMOS LA IMAGEN CORRECTA.**

5º **LEEMOS LAS PALABRAS Y SEGUIMOS LA PAUTA PARA ESCRIBIR LAS PALABRAS**

6º **COPIAMOS.** En esta actividad presentamos la imagen con la palabra escrita y una pauta para que la copie. Rodeamos la letra que estemos trabajando.

7º **Elige si están bien o mal escritas estas palabras.** Esta actividad consiste en decidir cuál de las palabras que aparecen al lado de las imágenes (ya trabajadas) está bien escrita o está mal. Para ello, el alumno/a pondrá un tic verde en la que esté bien escrita y una cruz roja en la que esté mal. El género es un aspecto que hemos ido trabajando de forma directa, con ejercicios específicos, en los cuadernillos 1, 2 y 3. En esta ocasión hemos decidido introducirlo de forma transversal para afianzar y generalizar lo aprendido en los cuadernillos anteriores.

8º **MAYÚSCULA Y MINÚSCULA.** Hasta el momento todo lo hemos trabajado con letras mayúsculas. Esta actividad consistirá en presentar las palabras, con su imagen, en mayúscula y luego verla en minúscula. Trabajar las diferencias y sobre todo la forma de la letra que estemos trabajando. Tras esta tarea, la siguiente será unir la palabra mayúscula con su minúscula.

9º EMPEZAMOS CON LAS SÍLABAS. Cogemos la imagen impresa a color y plastificada y la cortamos en trozos ¿Cuántos? Tantos trozos como sílabas tenga la palabra. El niño o niña ordenará la imagen como si fuese un puzle y nosotr@s colocaremos las sílabas a nivel escrito debajo de la imagen formada. Poco a poco lo irá haciendo el alumno o alumna. Es importante empezar con palabras bisílabas y posteriormente ir aumentando la dificultad.

10º ¿QUÉ SÍLABA FALTA? Presentamos las imágenes con la palabra incompleta bajo las mismas. Debemos averiguar qué sílaba falta. En esa actividad utilizo, al principio, las bocas del programa DI ya que ayudan al niño/niña a reconocer la sílaba a nivel escrito.

11º LLEGAMOS A LOS GRAFEMAS. Recortamos las letras de la izquierda. El niño/niña tendrá que ordenar las letras para formar la palabra según corresponda el dibujo. Prestaremos más atención al grafema que estemos trabajando.

METODOLOGÍA

Debemos tener muy presente que no todos los niños y niñas completarán todas las fases. Para el alumnado que tiene preferencia por los métodos globales no siempre es fácil pasar a la sílaba y menos aún a la letra. Aún así, hemos realizado fichas del trazo de la letra a que estemos trabajando, no para trabajar el sonido de la misma sino, como ya hemos dicho, para trabajar el trazo.

Mi alumno en concreto, trabaja perfectamente con el método global y reconoce a nivel visual y escrito la letra, su dificultad reside en la sílaba. Por este motivo surgió la idea de los puzles silábicos, además, he colocado en el suelo washi tape (parecido al fiso o celo de colores) formando una rayuela y en cada número vamos colocando una parte del puzle con una sílaba.

El material es fotocopiable. Las imágenes son más llamativas a color y si las plastificáis se manipulan mejor. El tamaño lo dejo a vuestra elección pero a mayor tamaño más atención (al menos mi alumno).

Los pictogramas utilizados son obra de [Sergio Palao](#) para [CATEDU](#) (<http://catedu.es/arasaac/>) publicados bajo licencia [Creative Commons](#).

Este material se trabaja en el aula de Audición y Lenguaje, en su aula ordinaria se trabaja el PIPE de CEPE (cuadernillos de lectura y escritura).

EVALUACIÓN

Para evaluar, personalmente lo que hago es realizar actividades intercaladas que requieran de mayor conocimiento y autonomía. Si las realiza, es que está adquiriendo dicha fase. Tengo elaborada una lista con todas las palabras que aparecen para trabajar una letra determinada y es en dicha lista donde voy anotando si las lee sin el apoyo visual, y otra si las escribe.

El ritmo lo marca el niño o niña y no tu programación o las “ansias” que a veces tenemos profesionales y familiares de <<pasar a otra cosa, mariposa>> Si no avanzamos nada, puede que el fallo esté en el planteamiento de actividades, en el orden de las mismas o nuestra metodología a la hora de exponer la tarea. Es muy necesario una AUTOEVALUACIÓN de vez en cuando.

Espero que este material os sirva de ayuda ¡A TRABAJAR!



NOMBRE: _____

1. REPASA LOS PUNTOS. FORMA LA LETRA "R" «r» Y COLOREÁLA.

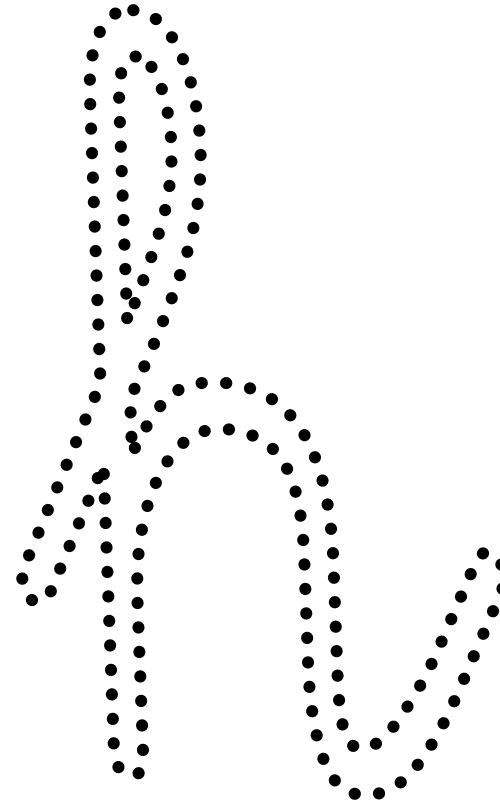
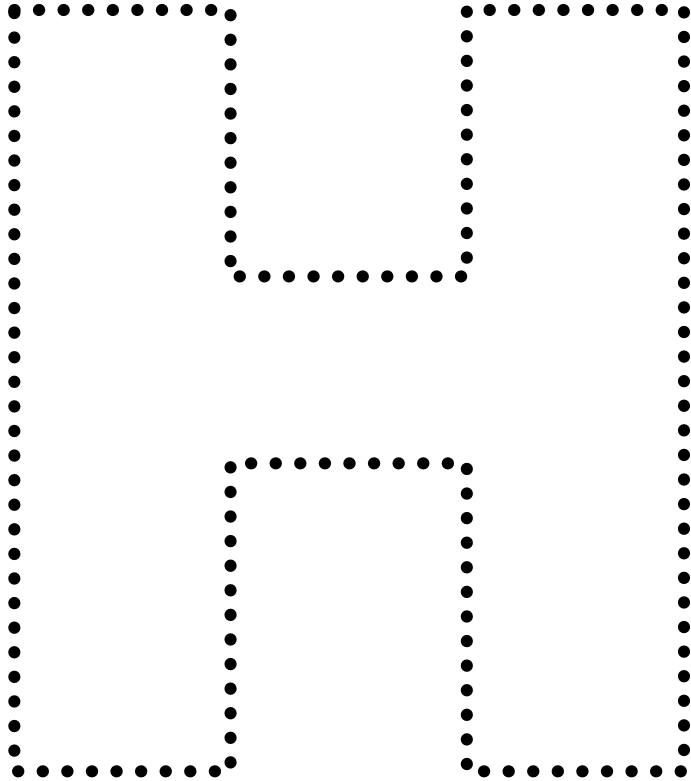

NOMBRE: _____

H H H H H H H H H

H H H H H H H H H

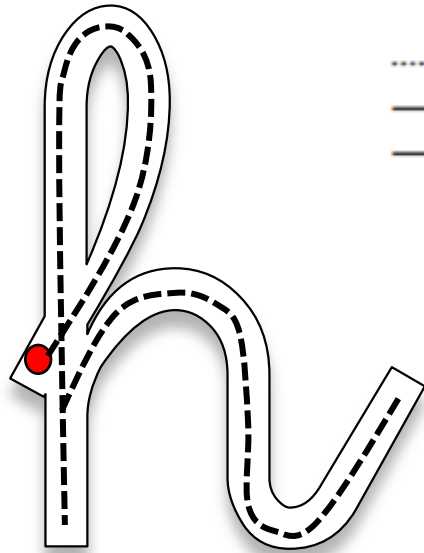
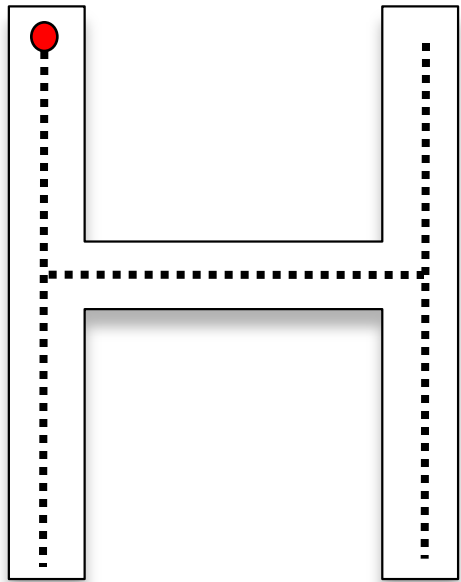

h h h h h h h h h

h h h h h h h h h

2. A continuación, podéis emplear las siguientes imágenes con sus letreros para el trabajo manipulativo diario con vuestro alumnado.

Personalmente, imprimo el material a color, le muestro al alumno/alumna la palabra con el letrero y subrayamos donde esté la “H”. Después lo plastifico.

HA

NOMBRE: _____

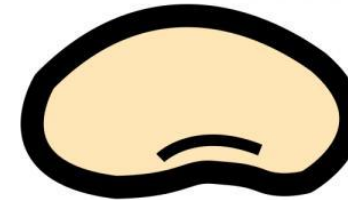
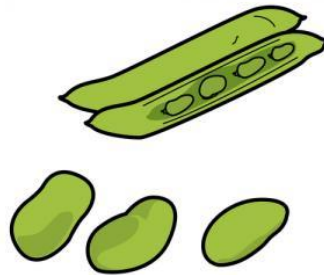
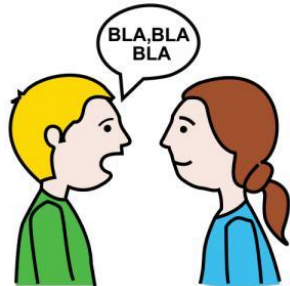
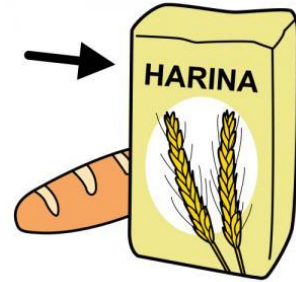

HAMACA

HARINA

HACHA

HADA

hamaca

harina

hacha

hada

HABLAR

HABAS

HABICHUELA

hablar

habas

habichuela

HE

NOMBRE: _____

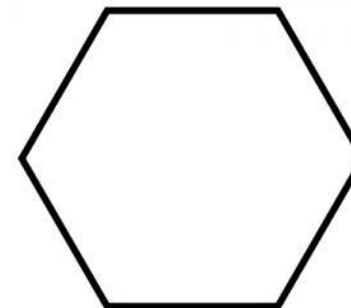
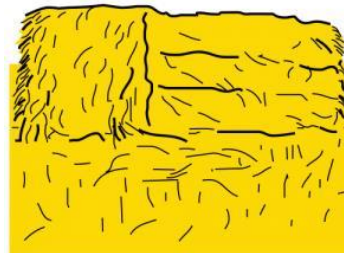
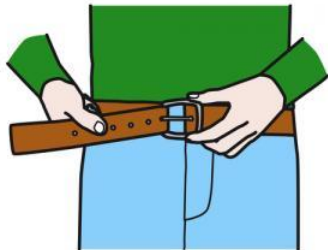
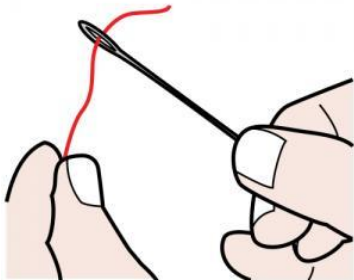

ENHEBRAR

HEBILLA

HELICÓPTERO

HERMOSO

enhebrar

hebillas

helicóptero

hermoso

HÉROE

HELADO

HENO

HEXÁGONO

héroe

helado

heno

hexágono

HI

NOMBRE: _____

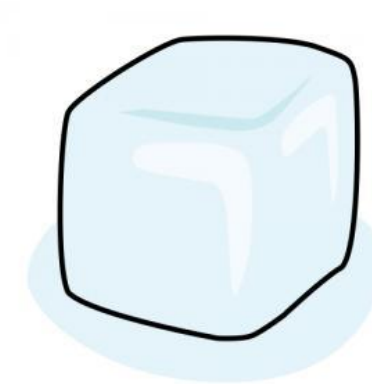
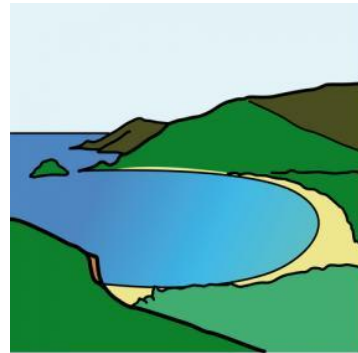
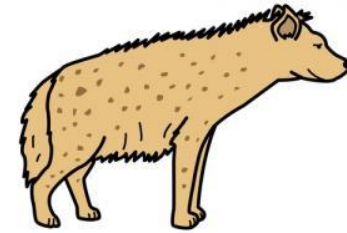
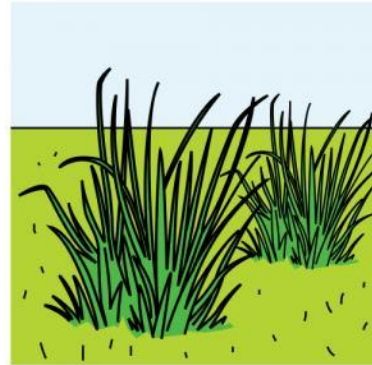
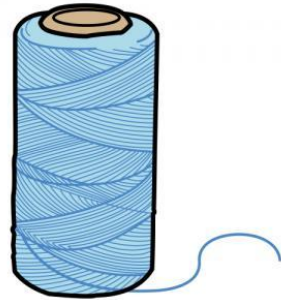
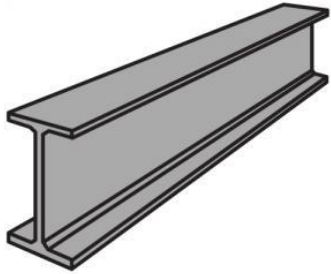

HIERRO

HILO

HIERBA

HIENA

hierro

hilo

hierba

hiena

VEHÍCULOS

BAHÍA

HIELO

HIPO

vehículos

bahía

hielo

hipo

HO

NOMBRE: _____

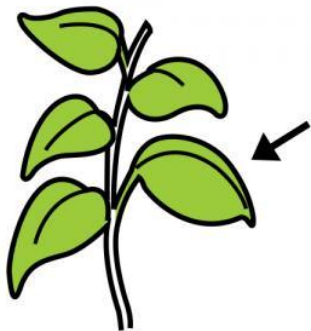
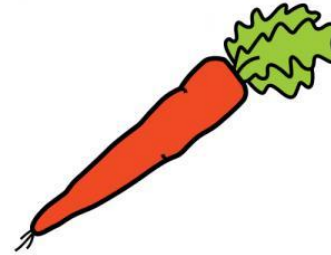
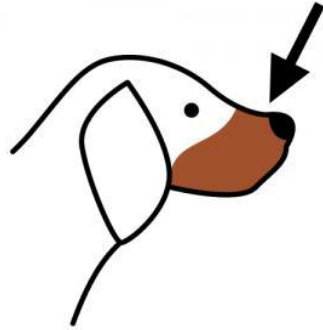

HOMBRE

HOCICO

HORNO

ZANAHORIA

hombre

hocico

horno

zanahoria

HOJA

HOSPITAL

HOLA

HOGUERA

hoja

hospital

hola

hoguera

HU

NOMBRE: _____

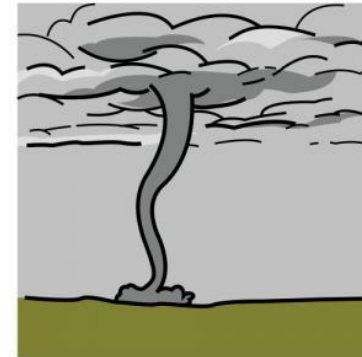
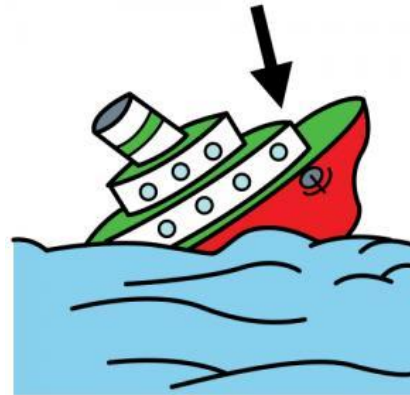
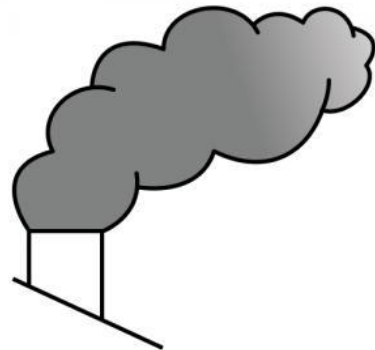
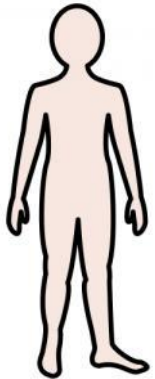
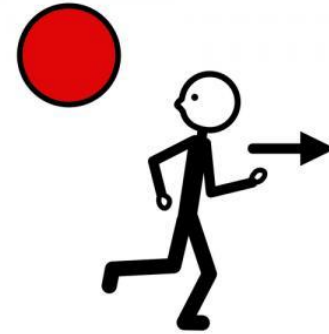
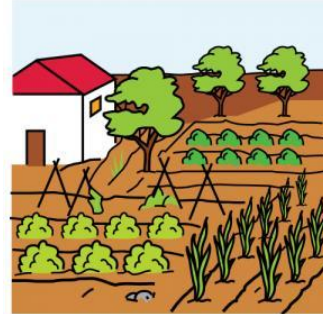
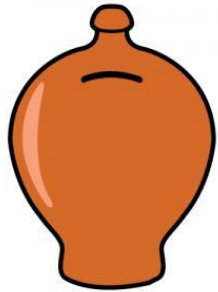

HUCHA

HUELLA

HUERTA

HUIR

hucha

huella

huerta

huir

HUMANO

HUMO

HUNDIR

HURACÁN

humano

humo

hundir

huracán



NOMBRE: _____

3. LEE. LUEGO RECORTA LAS IMÁGENES Y FORMAMOS OTRA VEZ LAS FRASES

El

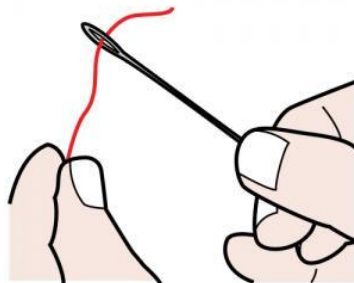

el

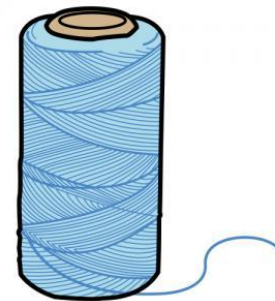

El

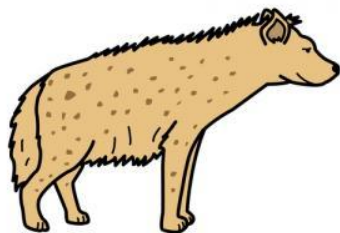

no

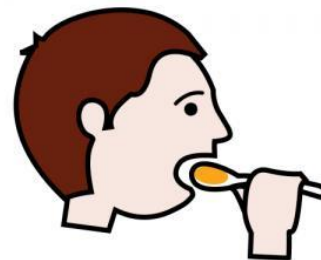



NOMBRE: _____

3. LEE. LUEGO RECORTA LAS IMÁGENES Y FORMAMOS OTRA VEZ LAS FRASES

El

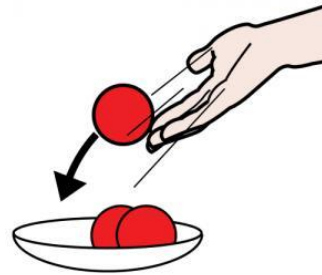

La

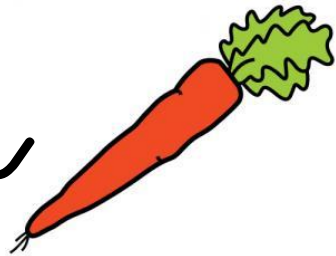

y el

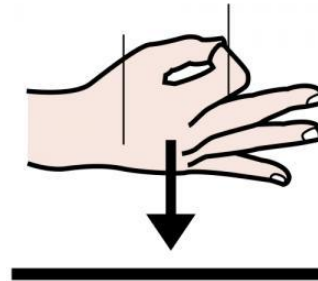
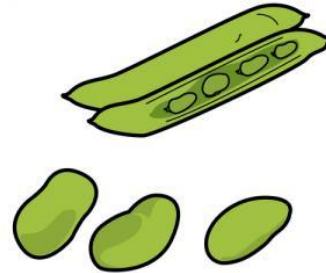

en la



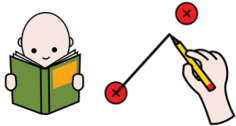

4. LEE. UNE CON LA IMAGEN CORRECTA

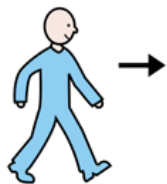
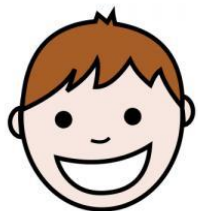

HILARIO	VA	AL	HOSPITAL
---------	----	----	----------

<i>Hilario</i>	<i>va</i>	<i>al</i>	<i>hospital</i>
----------------	-----------	-----------	-----------------

NOMBRE: _____

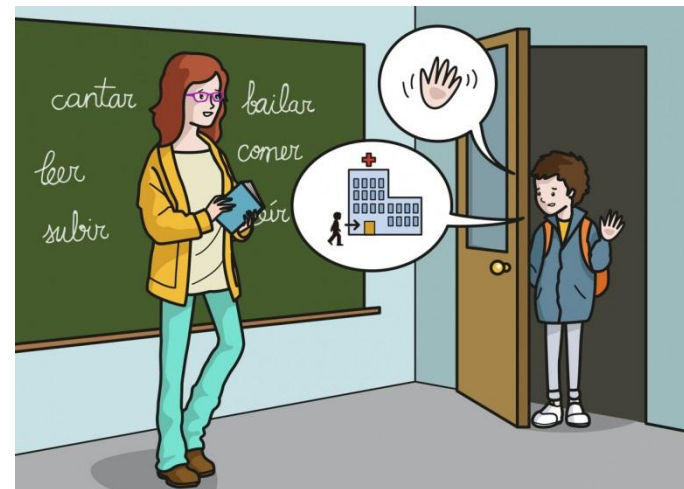

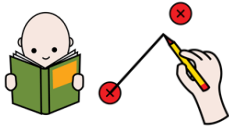

4. LEE. UNE CON LA IMAGEN CORRECTA



LA	ABUELA	COME	UN	HELADO
----	--------	------	----	--------

La	abuela	come	un	helado
----	--------	------	----	--------

NOMBRE: _____

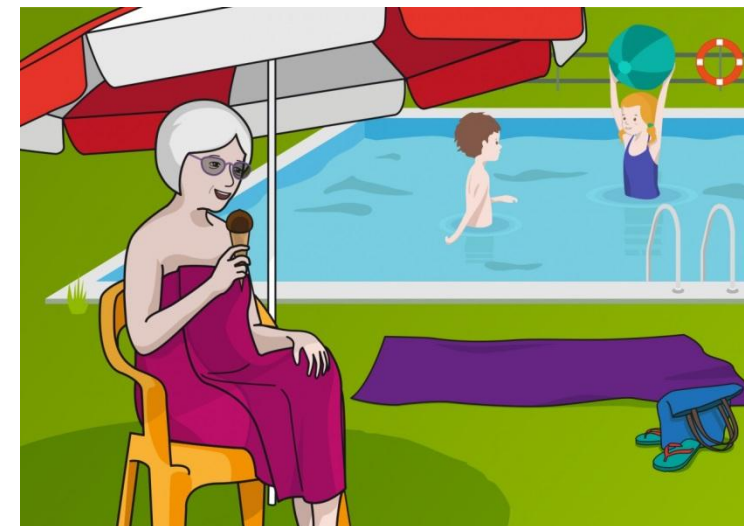

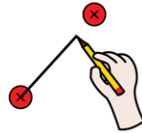

NOMBRE: _____

5. LEEMOS LAS PALABRAS. RODEAMOS LA “H” Y COPIAMOS. UNE DESPUÉS CON SU IMAGEN..

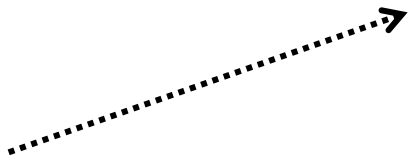

HARINA

HAMACA

HADA

HACHA

HARINA

HAMACA

HADA

HACHA

harina

hamaca

hada

hacha

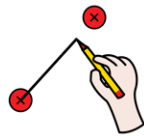

NOMBRE: _____

5. LEEMOS LAS PALABRAS. RODEAMOS LA "H" Y COPIAMOS. UNE DESPUÉS CON SU IMAGEN..

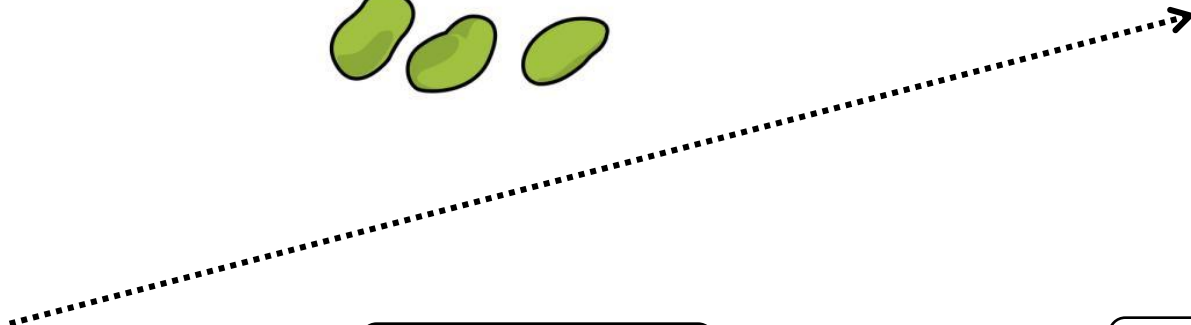
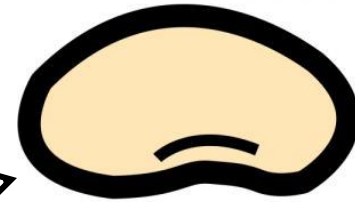
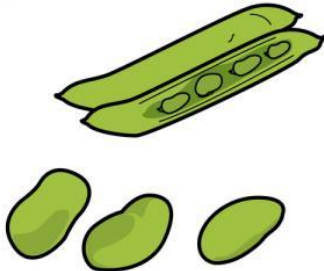

HABICHUELA

HABA

HABLAR

HABICHUELA

HABA

HABLAR

habichuela

haba

hablar

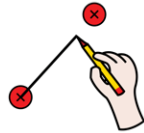

NOMBRE: _____

5. LEEMOS LAS PALABRAS. RODEAMOS LA “H” Y COPIAMOS. UNE DESPUÉS CON SU IMAGEN..

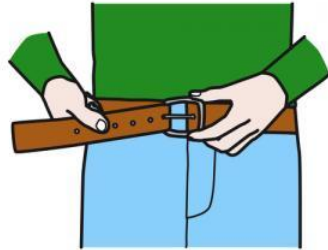
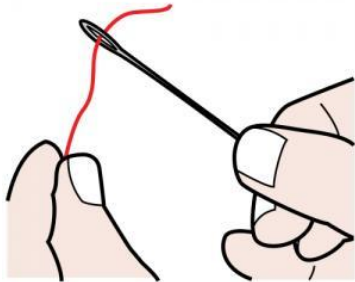

HEBILLA

HELICÓPTERO

ENHEBRAR

HERMOSO

HEBILLA

HELICÓPTERO

ENHEBRAR

HERMOSO

hebilla

helicóptero

enhebrar

hermoso

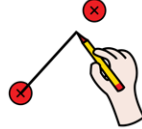

NOMBRE: _____

5. LEEMOS LAS PALABRAS. RODEAMOS LA "H" Y COPIAMOS. UNE DESPUÉS CON SU IMAGEN..

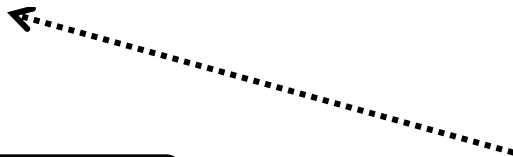
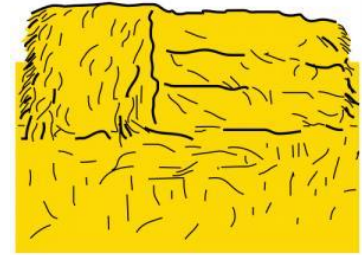
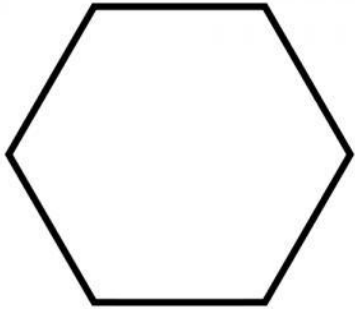

HELADO

HEXÁGONO

HÉROE

HENO

HELADO

HELICÓPTERO

HÉROE

HENO

helado

helicóptero

héroe

heno

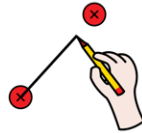

NOMBRE: _____

5. LEEMOS LAS PALABRAS. RODEAMOS LA “H” Y COPIAMOS. UNE DESPUÉS CON SU IMAGEN..

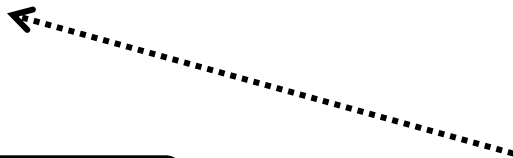
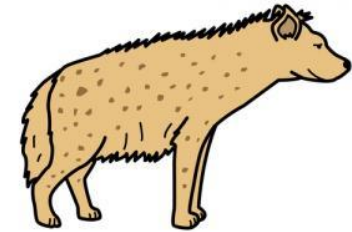
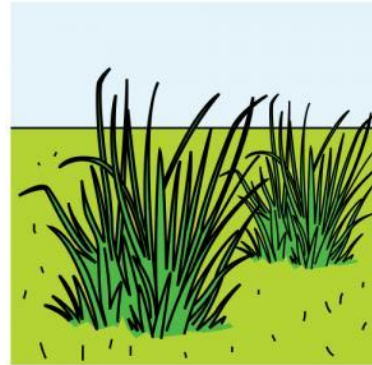
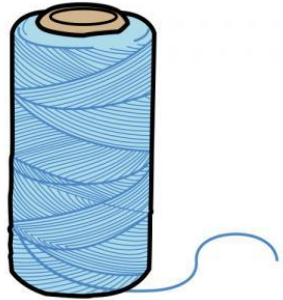
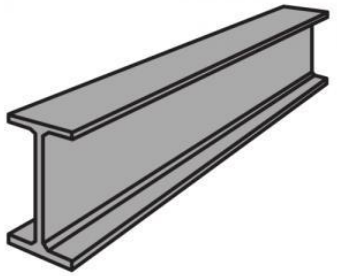

HIERBA

HIERRO

HIENA

HILO

HIERBA

HIERRO

HIENA

HILO

hierba

hierro

hiena

hilo

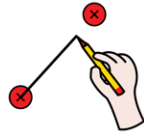

NOMBRE: _____

5. LEEMOS LAS PALABRAS. RODEAMOS LA “H” Y COPIAMOS. UNE DESPUÉS CON SU IMAGEN..

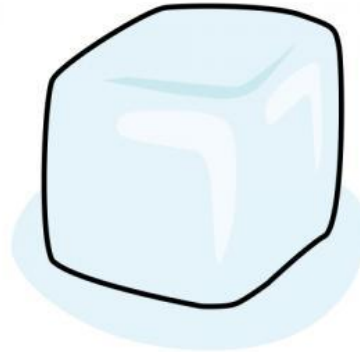
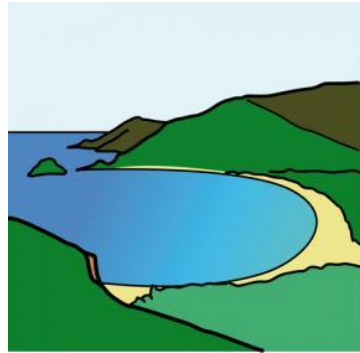

BAHÍA

VEHÍCULOS

HIELO

HIPO

BAHÍA

VEHÍCULOS

HIELO

HIPO

bahía

vehículos

hielo

hipo

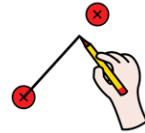

NOMBRE: _____

5. LEEMOS LAS PALABRAS. RODEAMOS LA “H” Y COPIAMOS. UNE DESPUÉS CON SU IMAGEN..

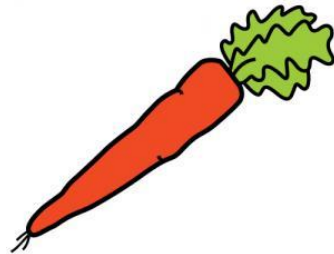

HORNO

ZANAHORIA

HOCICO

HOMBRE

HORNO

ZANAHORIA

HOCICO

HOMBRE

horno

zanahoria

hocico

hombre

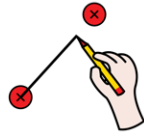

NOMBRE: _____

5. LEEMOS LAS PALABRAS. RODEAMOS LA “H” Y COPIAMOS. UNE DESPUÉS CON SU IMAGEN..

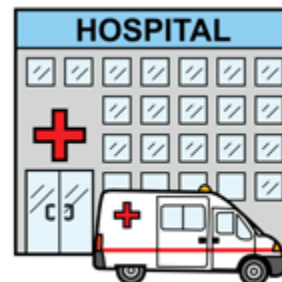
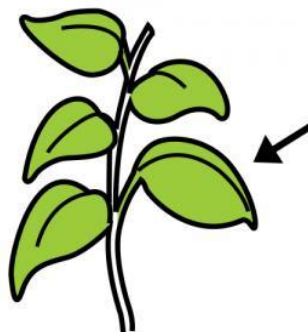

HOJAS

HOGUERA

HOSPITAL

HOLA

HOJAS

HOGUERA

HOSPITAL

HOLA

hojas

hoquera

hospital

hola

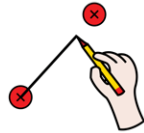

NOMBRE: _____

5. LEEMOS LAS PALABRAS. RODEAMOS LA “H” Y COPIAMOS. UNE DESPUÉS CON SU IMAGEN..

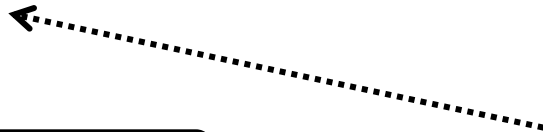
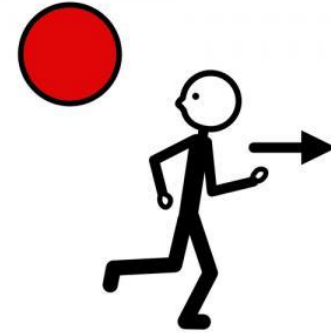
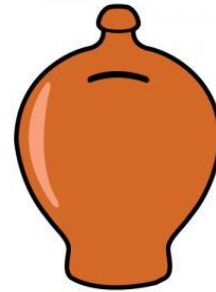

HUELLA

HUERTA

HUCHA

HUIR

HUELLA

HUERTA

HUCHA

HUIR

huella

huerta

hucha

huir

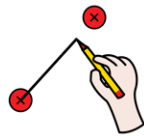

NOMBRE: _____

5. LEEMOS LAS PALABRAS. RODEAMOS LA “H” Y COPIAMOS. UNE DESPUÉS CON SU IMAGEN..

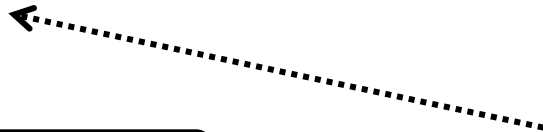
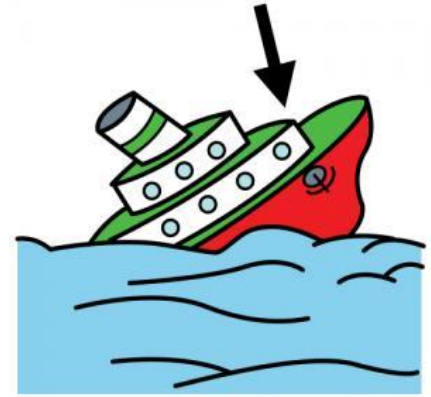
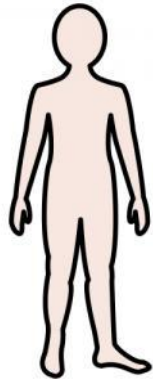
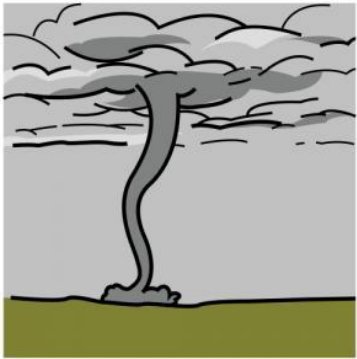

HUMANANO

HURACÁN

HUNDIR

HUMO

HUMANANO

HURACÁN

HUNDIR

HUMO

humano

huracán

hundir

humo

la manzana



casa *s

amor

mano

NOMBRE: _____

6. COPIA LAS PALABRAS.

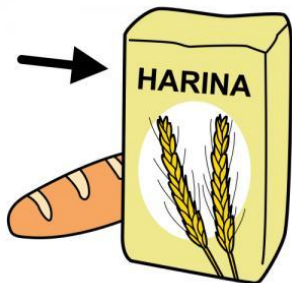

HAMACA

HARINA

HACHA

HADA

hamaca

harina

hacha

hada

la manzana



casa ^{+'s}

amor

mano

NOMBRE: _____

6. COPIA LAS PALABRAS.

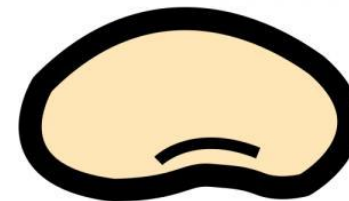
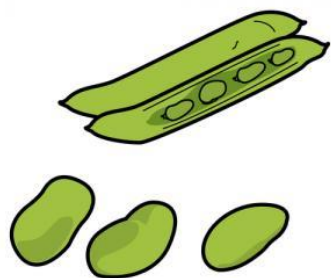
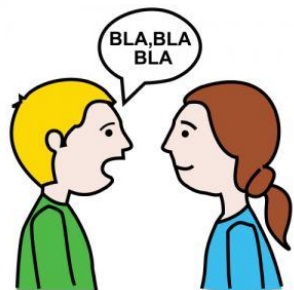

HABLAR

HABAS

HABICHUELA

hablar

habas

habichuela

la manzana



casa +s

amor

mano

NOMBRE: _____

6. COPIA LAS PALABRAS.

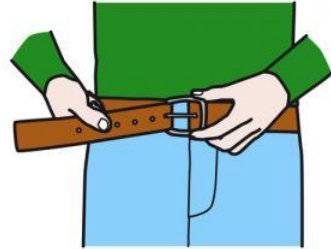
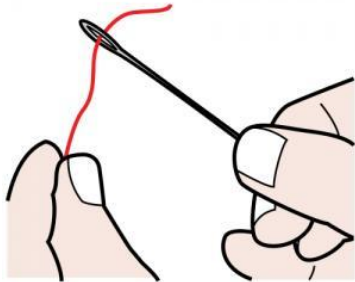

ENHEBRAR

HEBILLA

HERMOSO

HELICÓPTERO

enhebrar

hebilla

hermoso

helicóptero

la manzana



casa +s

amor

mano

NOMBRE: _____

6. COPIA LAS PALABRAS.

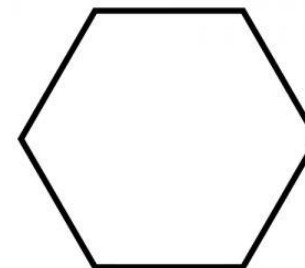
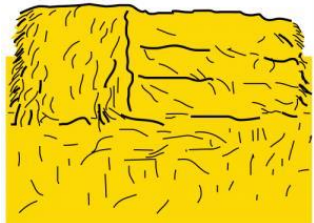

HENO

HELADO

HÉROE

HEXÁGONO

heno

helado

héroe

hexágono

la manzana
la mano

casa ^{+'s}
amor
mano

NOMBRE: _____

6. COPIA LAS PALABRAS.

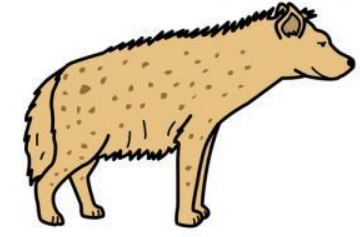
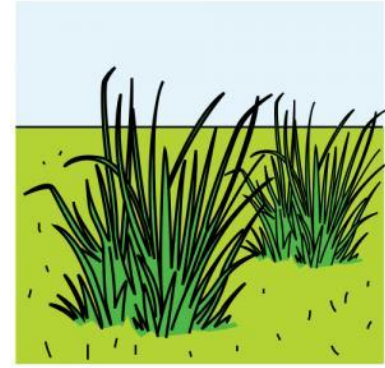
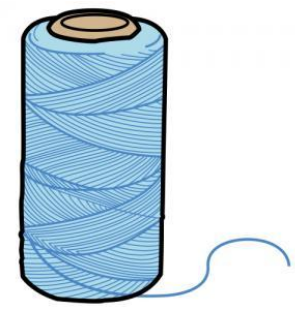
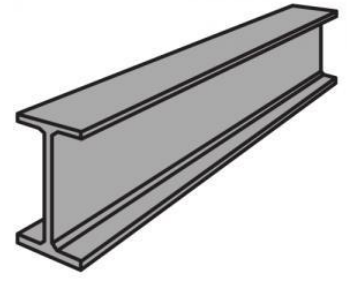

HIERRO

HILO

HIERBA

HIENA

hierro

hilo

hierba

hiena

la manzana



casa *s

amor

mano

NOMBRE: _____

6. COPIA LAS PALABRAS.

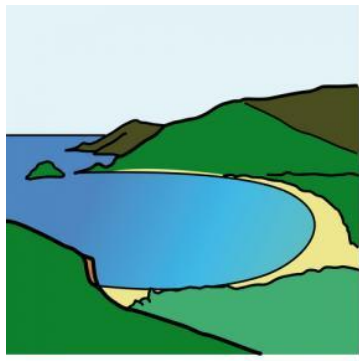

BAHÍA

HIELO

HIPO

VEHÍCULOS

bahía

hielo

hipo

vehículos

la manzana



casa *s

amor

mano

NOMBRE: _____

6. COPIA LAS PALABRAS.

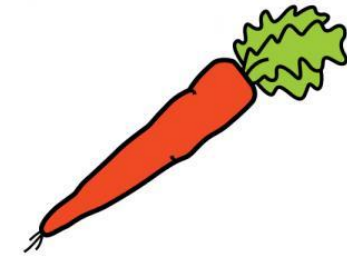
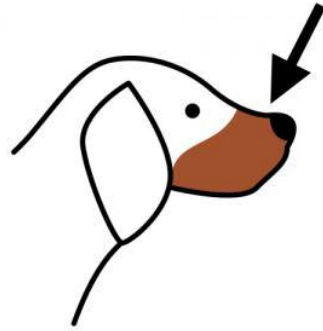

HORNO

HOCICO

HOMBRE

ZANAHORIA

horno

hocico

hombre

zanahoria

la manzana



casa ^{+s}

amor

mano

NOMBRE: _____

6. COPIA LAS PALABRAS.

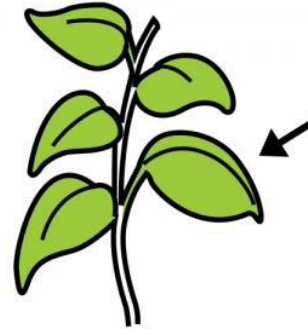
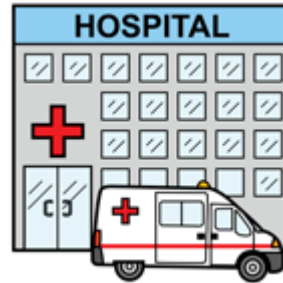

HOLA

HOSPITAL

HOJAS

HOGUERA

hola

hospital

hojas

hoguera

la manzana



casa +s

amor

mano

NOMBRE: _____

6. COPIA LAS PALABRAS.

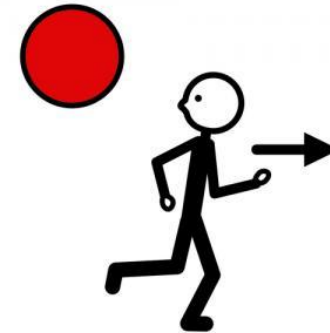
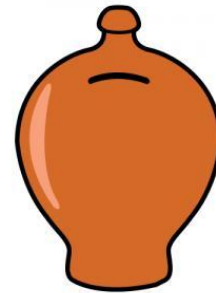

HUERTA

HUELLA

HUCHA

HUIR

huerta

huella

hucha

huir

la manzana



casa +s

amor

mano

NOMBRE: _____

6. COPIA LAS PALABRAS.

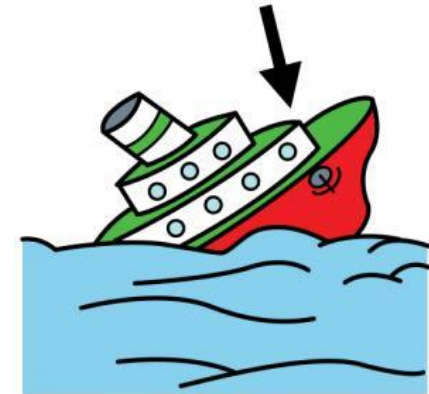
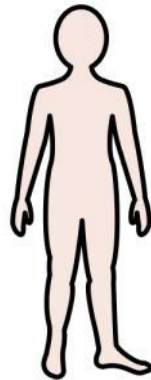
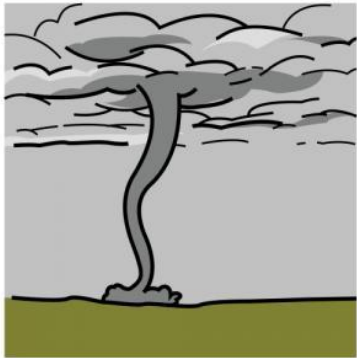

HURACÁN

HUMANO

HUMO

HUNDIR

huracán

humano

humo

hundir

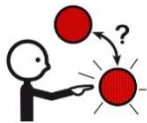

casa
amor
mano

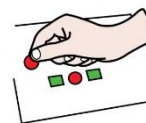

7. Elige si están bien o mal estas palabras. Pon V o X en el recuadro.



EL

HACHA



ALLA

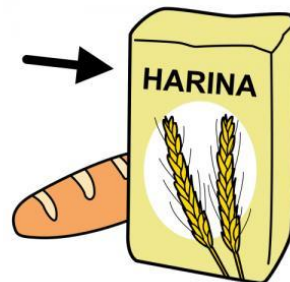

LA

ARINA

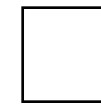

HARINA



EL

ADA

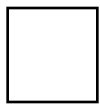

HADA

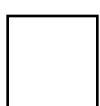

LA

MACA



HAMACA

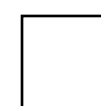

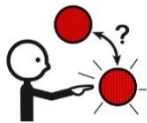

casa
amor
mano

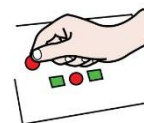

7. Elige si están bien o mal estas palabras. Pon V o X en el recuadro.



EL

HELICÓPTERO

LICOPTERO



LA

HEBILLA

EBILLA



EL

ELAO

HELADO

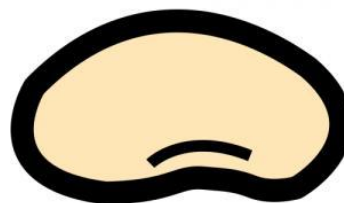

LA

BICHUELA

HABICHUELA

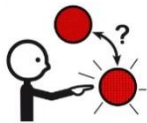

casa
amor
mano

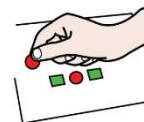

7. Elige si están bien o mal estas palabras. Pon V o X en el recuadro.

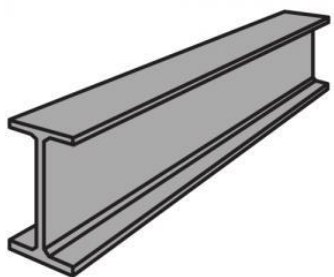

EL

YERRO

HIERRO

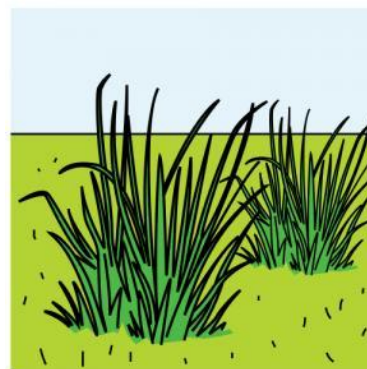

LA

HIERBA

YERBA

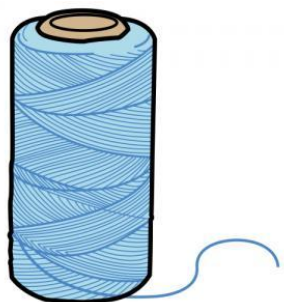

EL

HILO

ILO

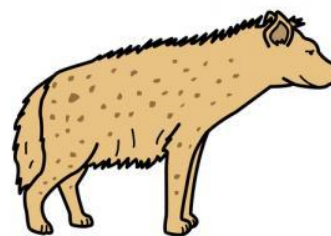

LA

HIENA

YENA

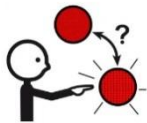

casa
amor
mano

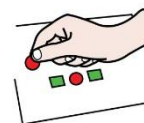

7. Elige si están bien o mal estas palabras. Pon V o X en el recuadro.



EL

HORNO

ORNO

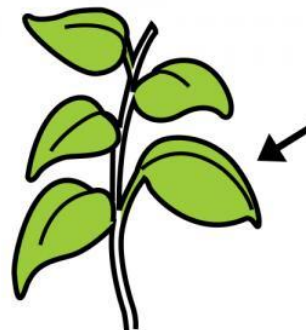

LA

HOJA

OGA



EL

JOCICO

HOCICO



LA

HOGUERA

OGUERA

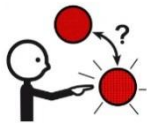

casa
amor
mano

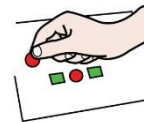

7. Elige si están bien o mal estas palabras. Pon V o X en el recuadro.



EL

OMBRE	<input type="checkbox"/>
HOMBRE	<input type="checkbox"/>

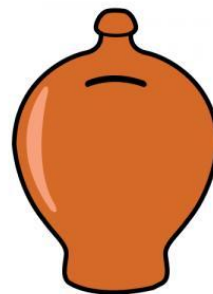

LA

ULLA	<input type="checkbox"/>
HUCHA	<input type="checkbox"/>

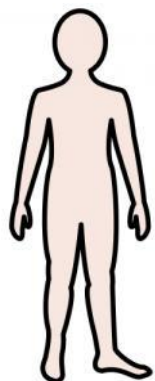

EL

HUMANO	<input type="checkbox"/>
UMANO	<input type="checkbox"/>

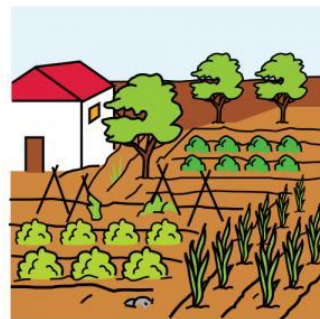

LA

GUERTA	<input type="checkbox"/>
HUERTA	<input type="checkbox"/>

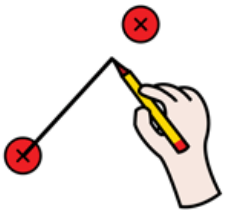

NOMBRE: _____

8. Para trabajar esta actividad recorta antes los carteles de las palabras escritas en mayúscula y minúscula que aparecen en las primeras fichas. Mirad y estudiar las diferencias. Unirlas antes a nivel manipulativo. Ahora lo haremos con el lápiz.

HABA

HAMACA

HARINA

HACHA

HADA

hamaca

haba

harina

hada

hacha

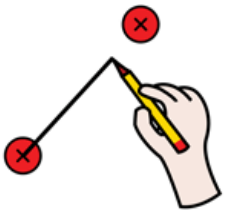

NOMBRE: _____

8. Para trabajar esta actividad recorta antes los carteles de las palabras escritas en mayúscula y minúscula que aparecen en las primeras fichas. Mirad y estudiar las diferencias. Unirlas antes a nivel manipulativo. Ahora lo haremos con el lápiz.

HEBILLA

HELADO

HENO

HÉROE

ENHEBRAR

HERMOSO

helado

heno

hermoso

enhebrar

hebilla

héroe

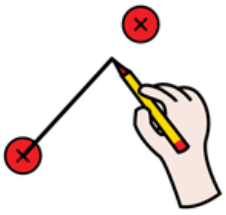

NOMBRE: _____

8. Para trabajar esta actividad recorta antes los carteles de las palabras escritas en mayúscula y minúscula que aparecen en las primeras fichas. Mirad y estudiar las diferencias. Unirlas antes a nivel manipulativo. Ahora lo haremos con el lápiz.

HIPO

HIELO

HIENA

HIERBA

HIERRO

BAHÍA

hielo

hipo

hierba

hiena

bahía

hierro

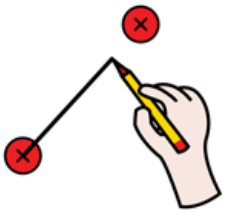

NOMBRE: _____

8. Para trabajar esta actividad recorta antes los carteles de las palabras escritas en mayúscula y minúscula que aparecen en las primeras fichas. Mirad y estudiar las diferencias. Unirlas antes a nivel manipulativo. Ahora lo haremos con el lápiz.

HOMBRE

HOCICO

HOGUERA

HOJAS

HORNO

HOLA

hojas

hombre

horno

hoguera

hocico

hola

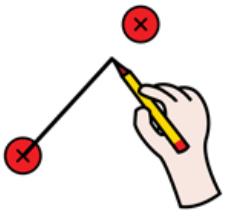

NOMBRE: _____

8. Para trabajar esta actividad recorta antes los carteles de las palabras escritas en mayúscula y minúscula que aparecen en las primeras fichas. Mirad y estudiar las diferencias. Unirlas antes a nivel manipulativo. Ahora lo haremos con el lápiz.

HUMO

HUCHA

HURACÁN

HUNDIR

HUMANO

HUIR

huir

hucha

humo

huracán

hundir

humanos



9. Contamos las sílabas de las palabras. Cogemos todas las imágenes trabajadas y las recortamos de manera irregular en tantos trozos como sílabas tenga la palabra. Después, las pegamos encima de su igual y ponemos el número de sílabas.

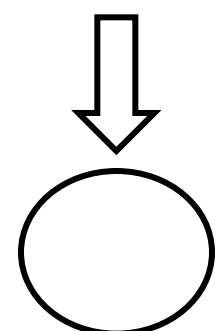
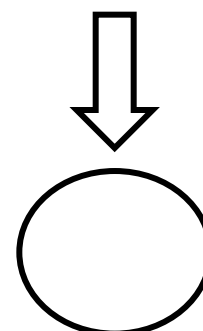
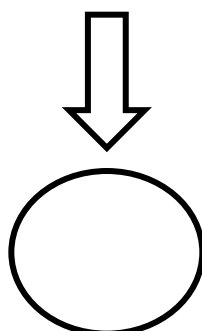
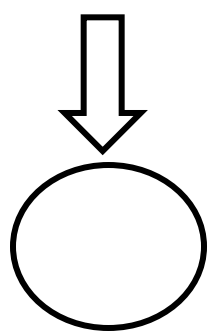
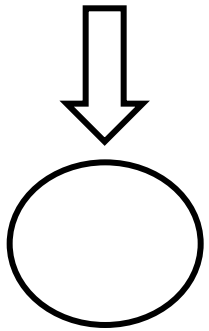
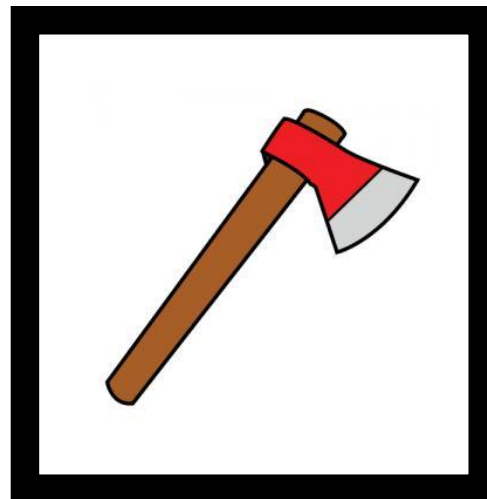
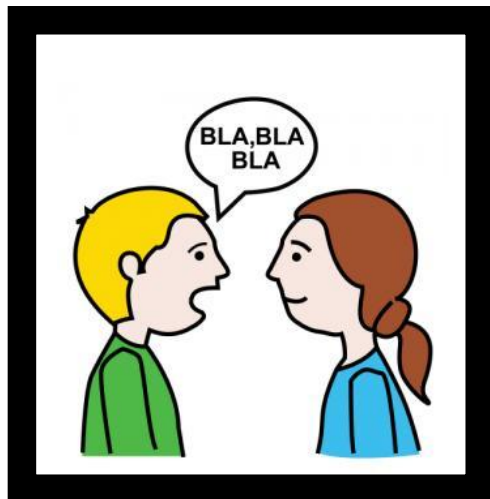
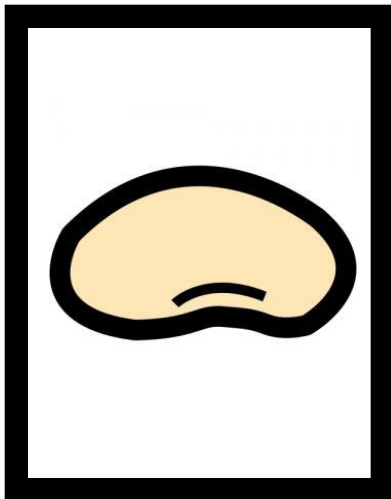
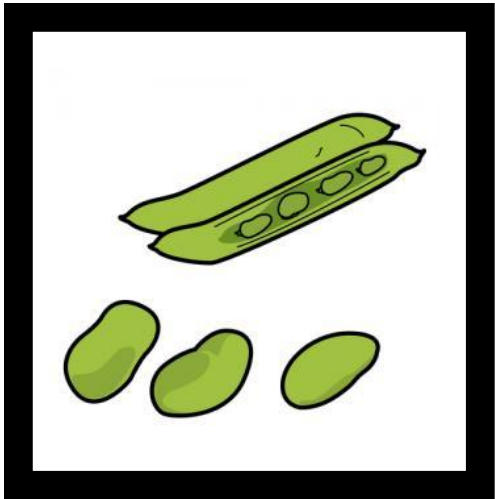

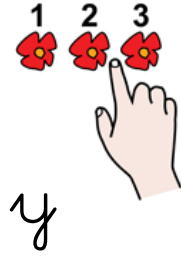

9. Contamos las sílabas de las palabras. Cogemos todas las imágenes trabajadas y las recortamos de manera irregular en tantos trozos como sílabas tenga la palabra. Después, las pegamos encima de su igual y ponemos el número de sílabas.

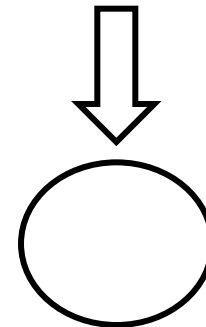
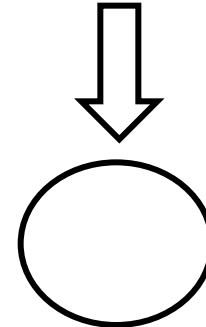
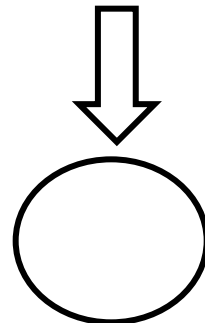
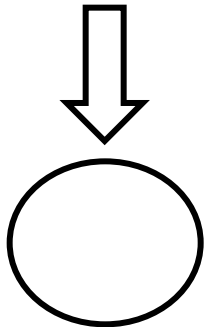
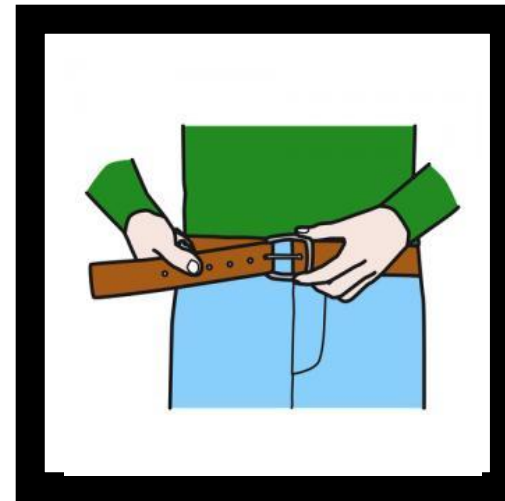
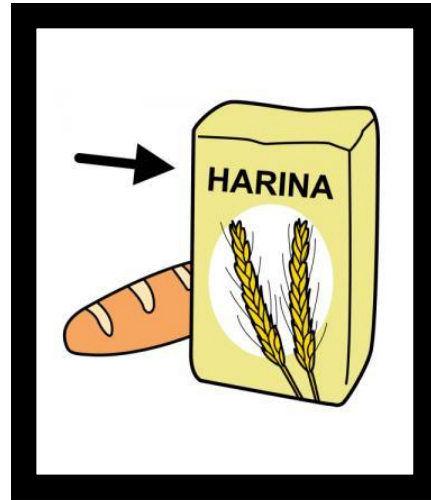

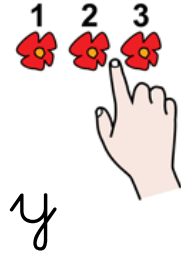

9. Contamos las sílabas de las palabras. Cogemos todas las imágenes trabajadas y las recortamos de manera irregular en tantos trozos como sílabas tenga la palabra. Después, las pegamos encima de su igual y ponemos el número de sílabas.

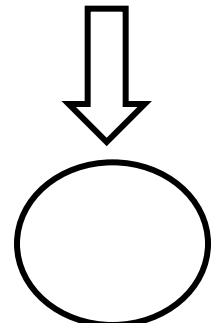
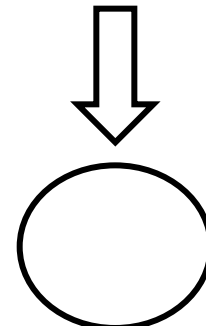
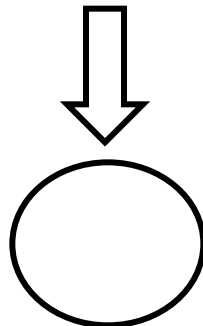
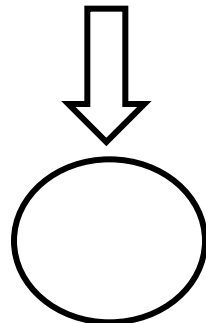
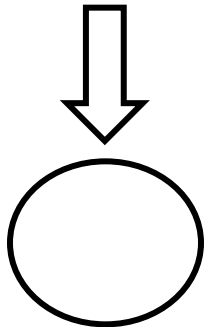
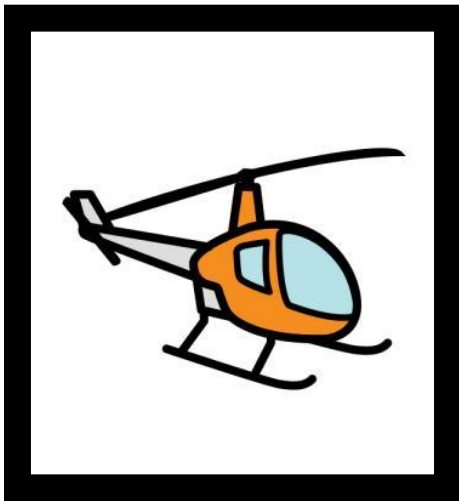
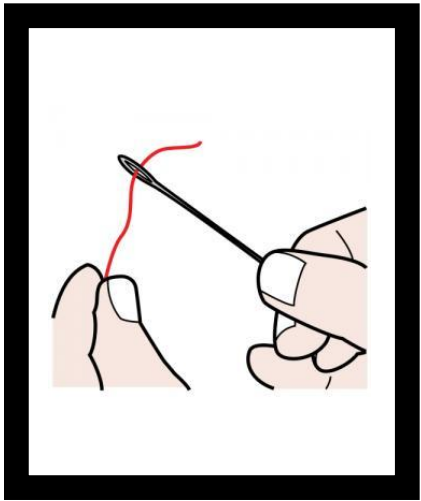

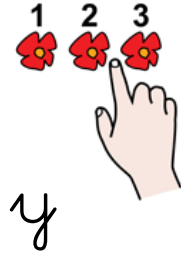

9. Contamos las sílabas de las palabras. Cogemos todas las imágenes trabajadas y las recortamos de manera irregular en tantos trozos como sílabas tenga la palabra. Después las pegamos encima de su igual y ponemos el número de sílabas.

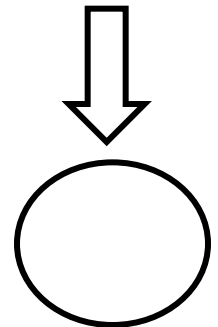
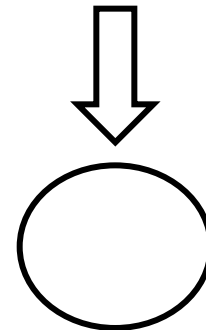
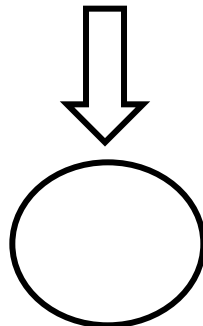
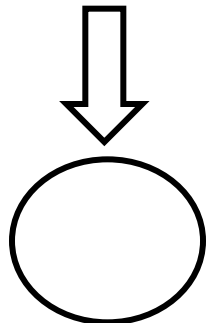
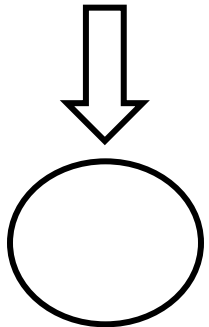
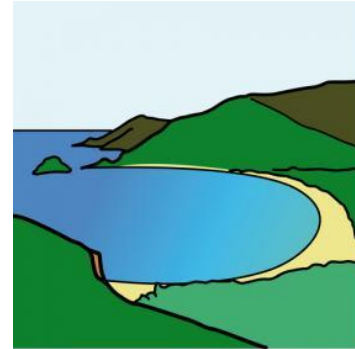
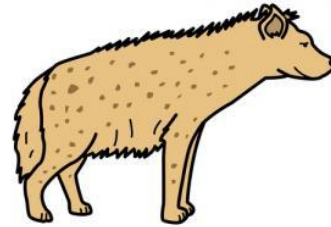
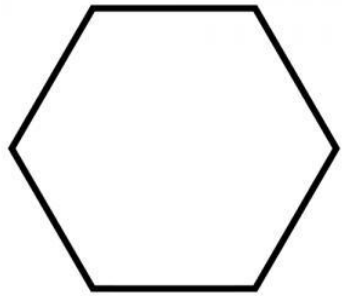

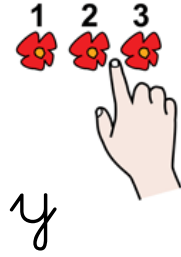

9. Contamos las sílabas de las palabras. Cogemos todas las imágenes trabajadas y las recortamos de manera irregular en tantos trozos como sílabas tenga la palabra. Después las pegamos encima de su igual y ponemos el número de sílabas.

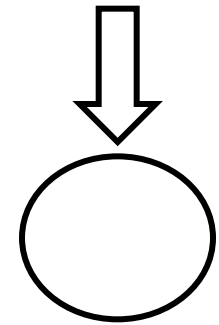
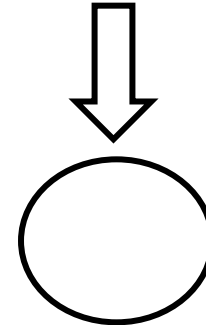
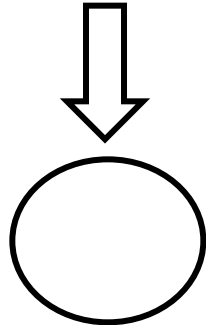
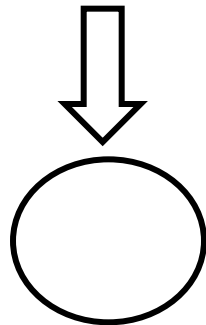
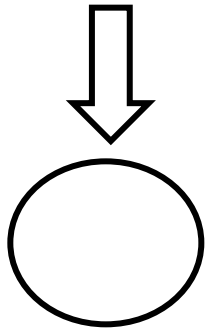
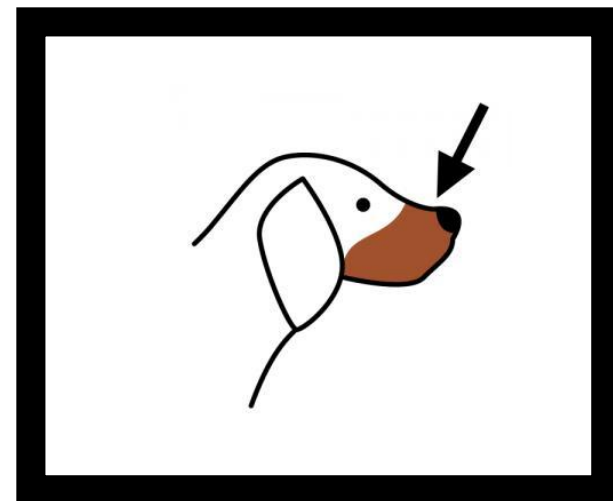
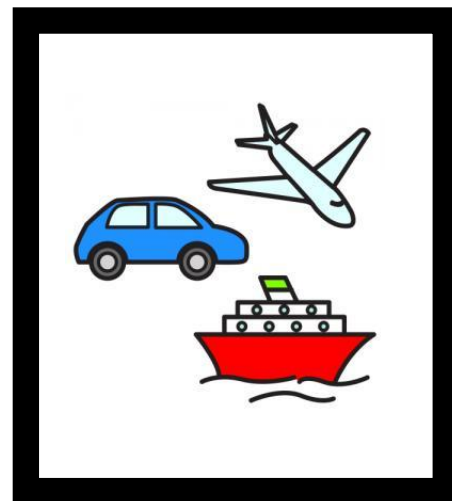
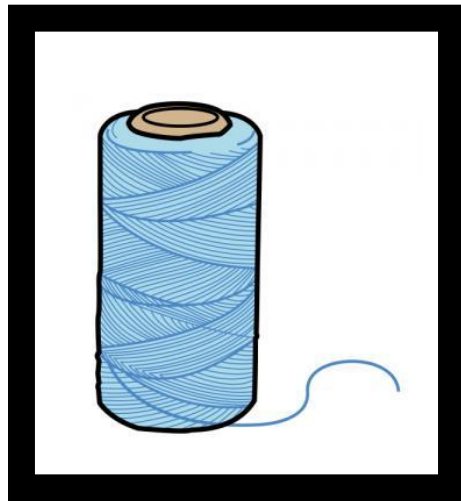
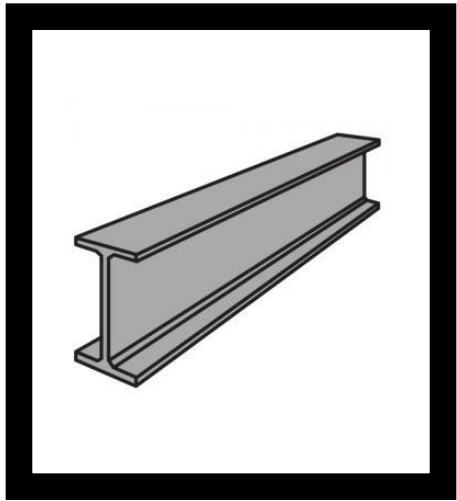



9. Contamos las sílabas de las palabras. Cogemos todas las imágenes trabajadas y las recortamos de manera irregular en tantos trozos como sílabas tenga la palabra. Después, las pegamos encima de su igual y ponemos el número de sílabas.

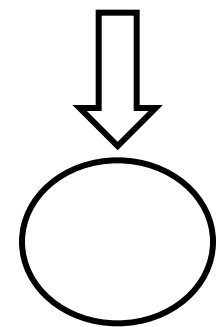
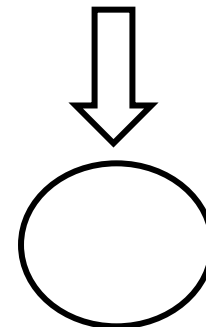
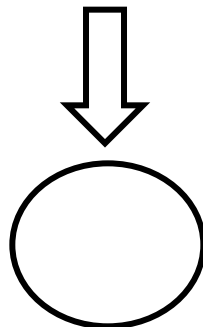
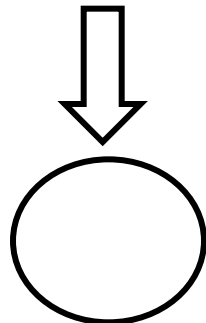
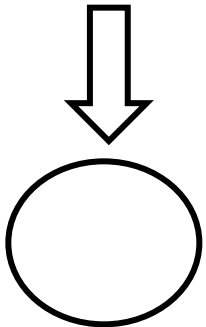
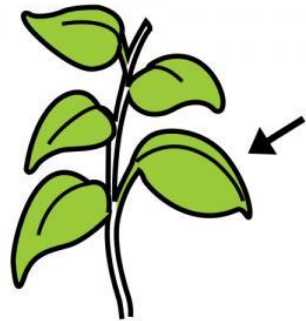

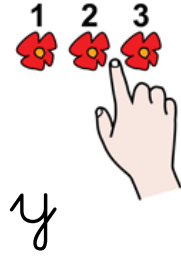

9. Contamos las sílabas de las palabras. Cogemos todas las imágenes trabajadas y las recortamos de manera irregular en tantos trozos como sílabas tenga la palabra. Después las pegamos encima de su igual y ponemos el número de sílabas.

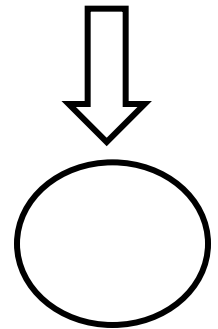
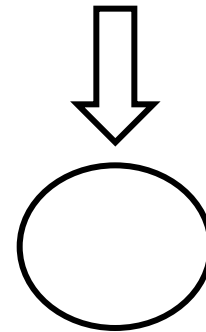
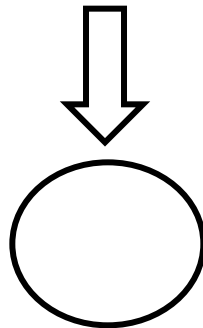
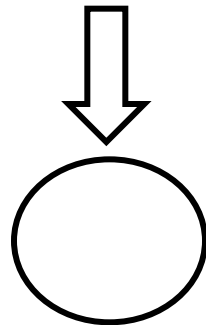
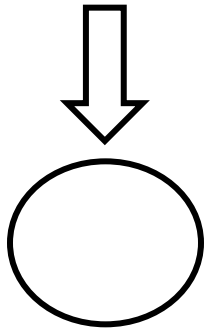
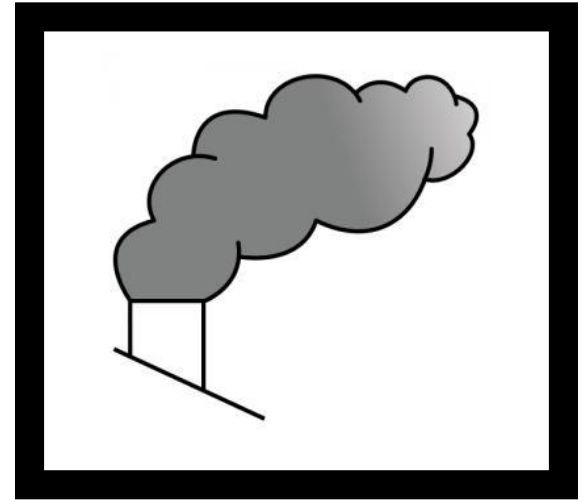
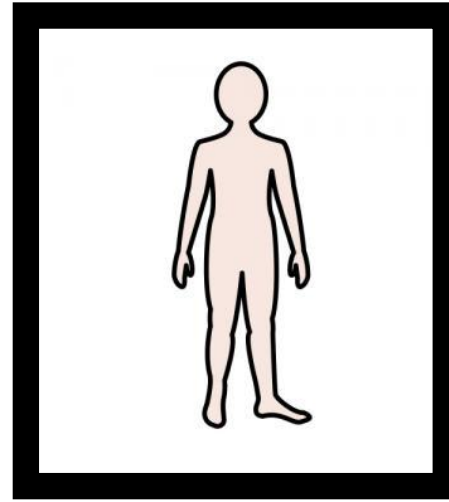
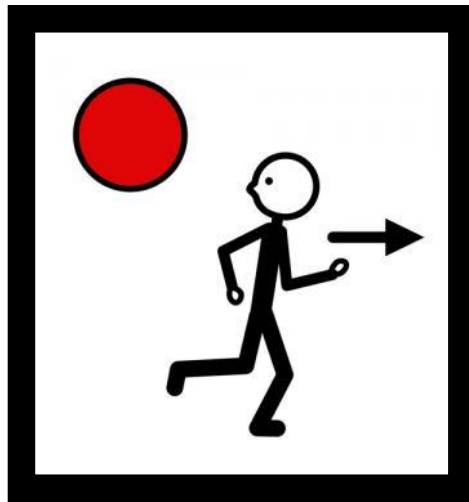
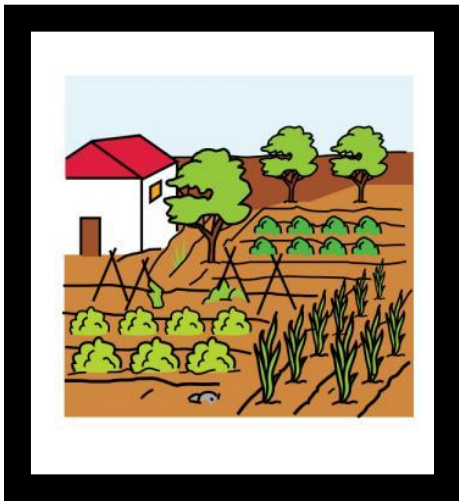
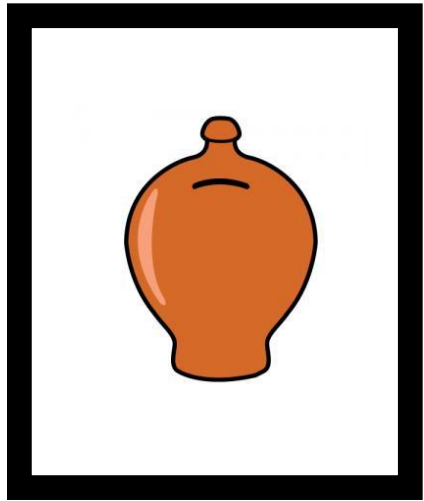



9. Contamos las sílabas de las palabras. Cogemos todas las imágenes trabajadas y las recortamos de manera irregular en tantos trozos como sílabas tenga la palabra. Después, las pegamos encima de su igual y ponemos el número de sílabas.

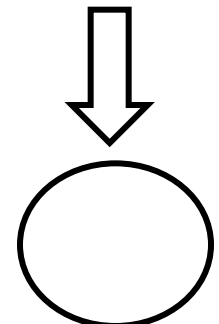
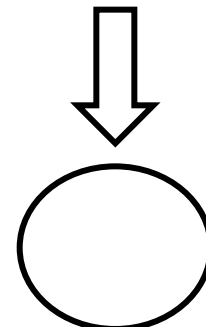
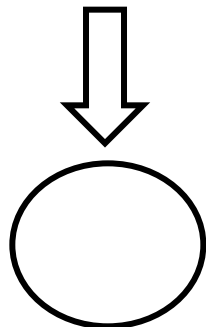
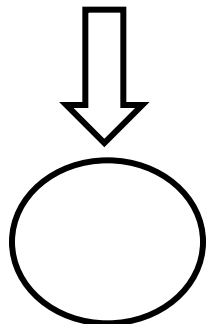
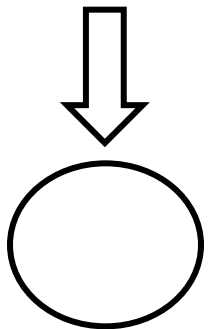
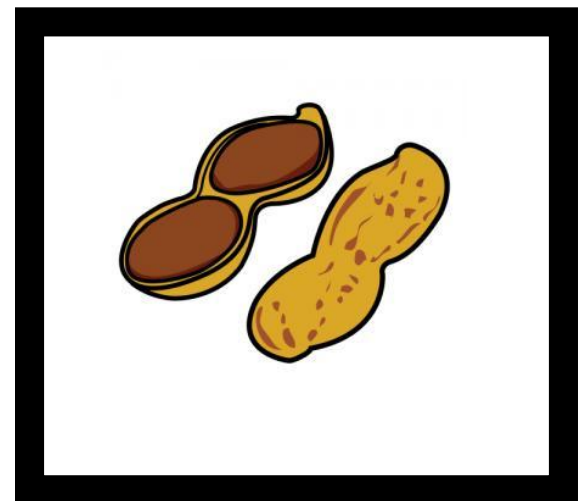
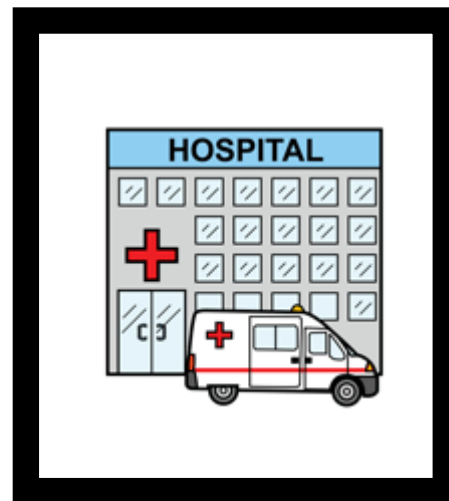
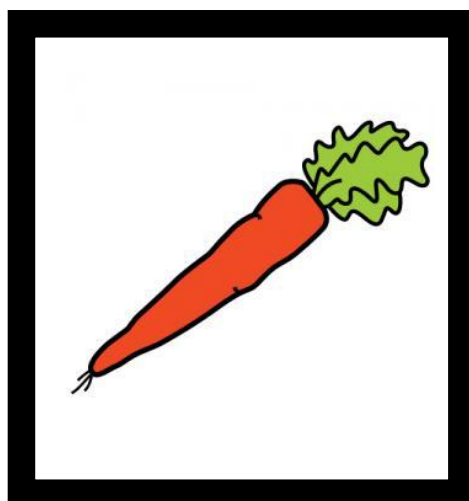
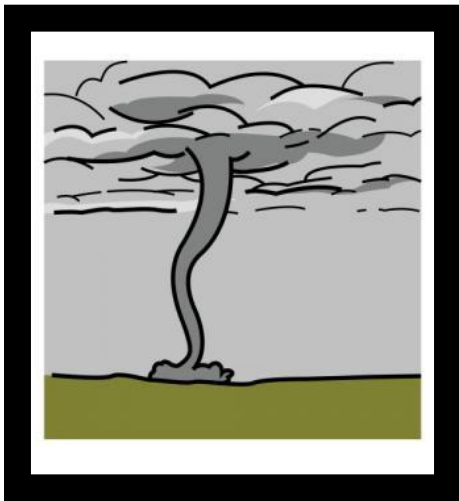
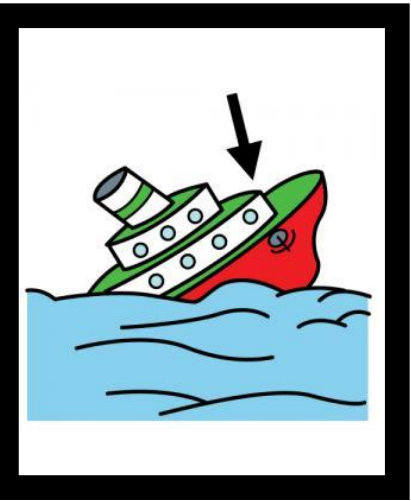



10. Escribe la sílaba correcta.

ha, he, hi, ho, hu

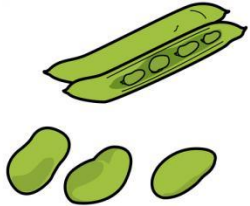

habas

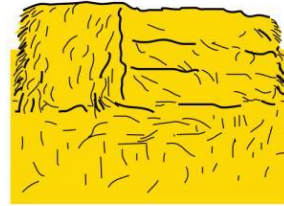

no



cha



roe

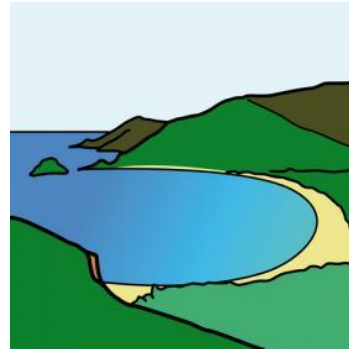

hia



10. Escribe la sílaba correcta. *ha, he, hi, ho, hu*



__ndir



__spital



__lado



__elo



__maca



●?○

10. Escribe la sílaba correcta. *ha, he, hi, ho, hu*

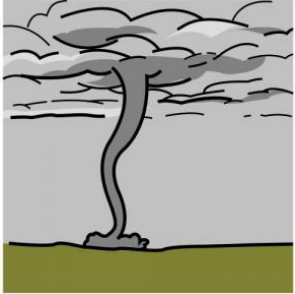

__racán



__la



__no



__quera



ve__culos



10. Escribe la sílaba correcta. *ha, he, hi, ho, hu*

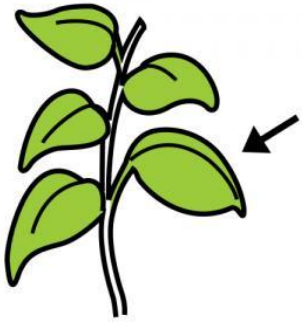

 jas



 erta

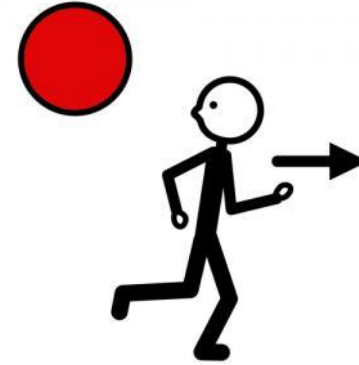

 ir

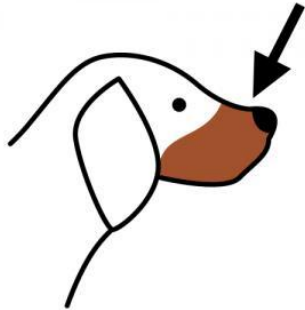

 cico



 mbre



10. Escribe la sílaba correcta. *ha, he, hi, ho, hu*

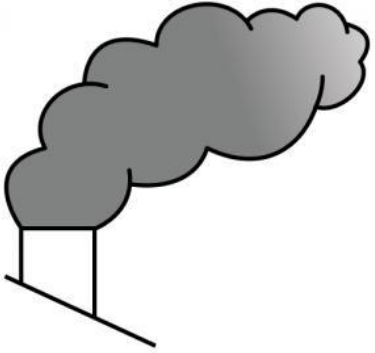

__me

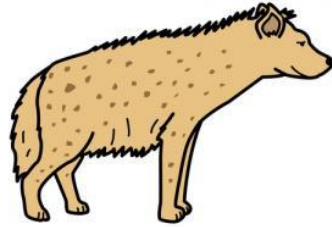

__ena

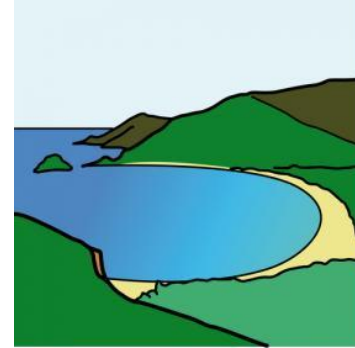

ba__a

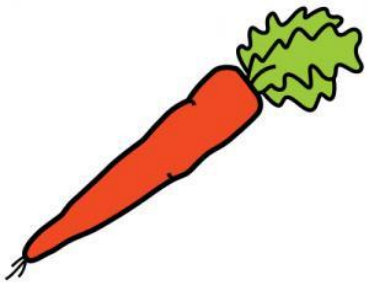

zana__ria



__rno



ABC...

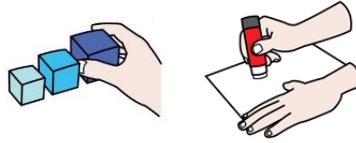

casa
amor
mano

11. Primero, recorta las letras. Luego, ordena y pega para formar una palabra.

O	I	L	H
---	---	---	---

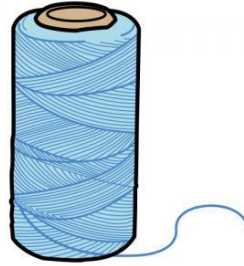

--	--	--	--

H	A	I	E	N
---	---	---	---	---

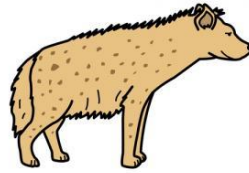

--	--	--	--	--

O	R	R	I	H	E
---	---	---	---	---	---

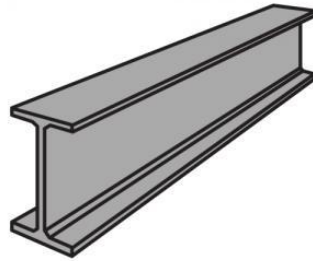

--	--	--	--	--	--



ABC...

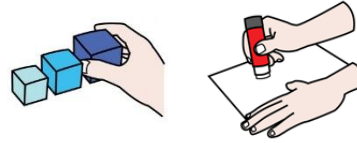

casa
amor
mano

11 Primero, recorta las letras. Luego, ordena y pega para formar una palabra.

L	H	O	L
---	---	---	---



--	--	--	--

U	H	M	O
---	---	---	---



--	--	--	--

U	H	R	E	T	A
---	---	---	---	---	---

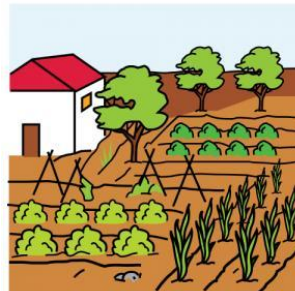

--	--	--	--	--	--



ABC...

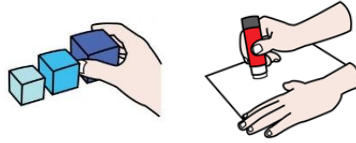

casa
amor
mano

11. *Primero, recorta las letras. Luego, ordena y pega para formar una palabra.*

O	N	E	H
---	---	---	---

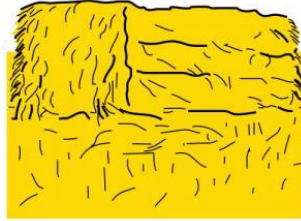

--	--	--	--

H	O	N	R	O
---	---	---	---	---



--	--	--	--	--

A	H	M	C	A	A
---	---	---	---	---	---



--	--	--	--	--	--



ABC...

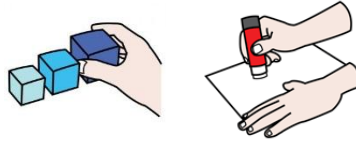

casa
amor
mano

11. Primero, recorta las letras. Luego, ordena y pega para formar una palabra.

H S O P A I L T



--	--	--	--	--

Z H A N A I R A O

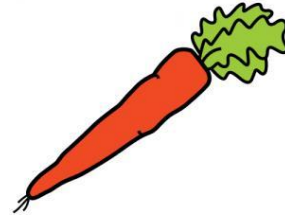

--	--	--	--	--	--	--	--	--	--

A H D A



--	--	--	--



ABC...

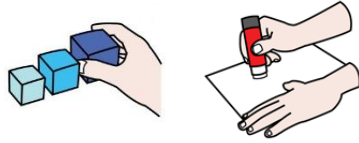

casa
amor
mano

11. Primero, recorta las letras. Luego, ordena y pega para formar una palabra.

H A I R N A

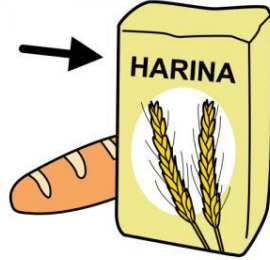

--	--	--	--	--	--

O H M E B R



--	--	--	--	--	--

H C H A A



--	--	--	--	--