



f Guía de Clases JB



# Matemática





Mi nombre es: \_\_\_\_\_



# Color rojo



Pega papel rasgado de color rojo (●) sobre la manzana.

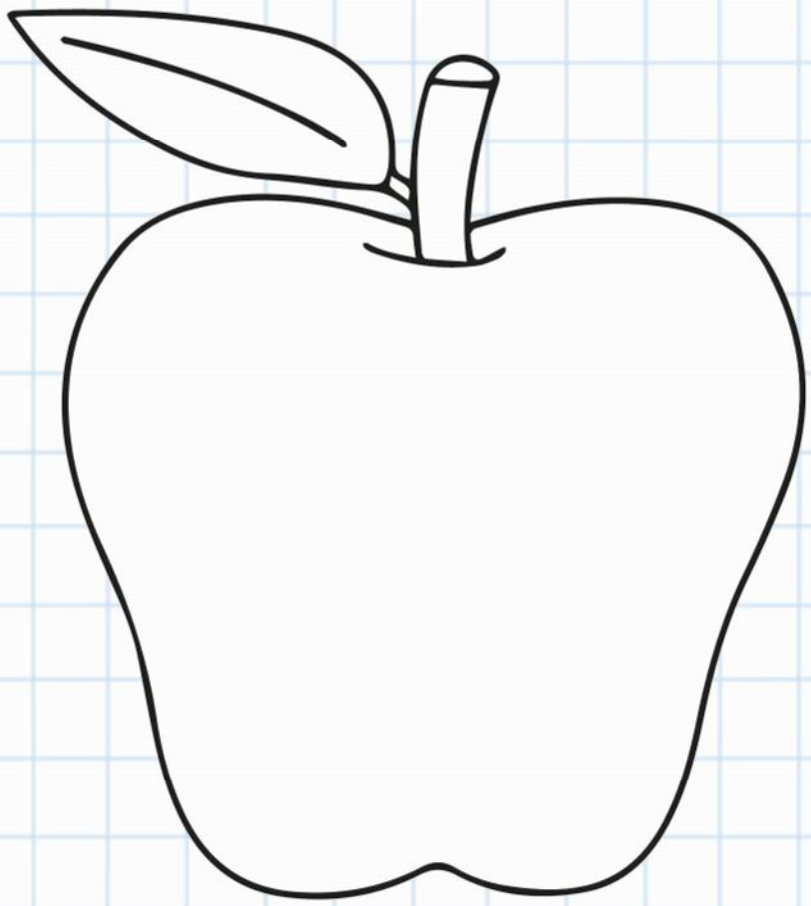



Mi nombre es: \_\_\_\_\_



de Clases JB

Pinta de color rojo (●) y embolilla por los puntos con papel rojo (●) por el borde del tomate.

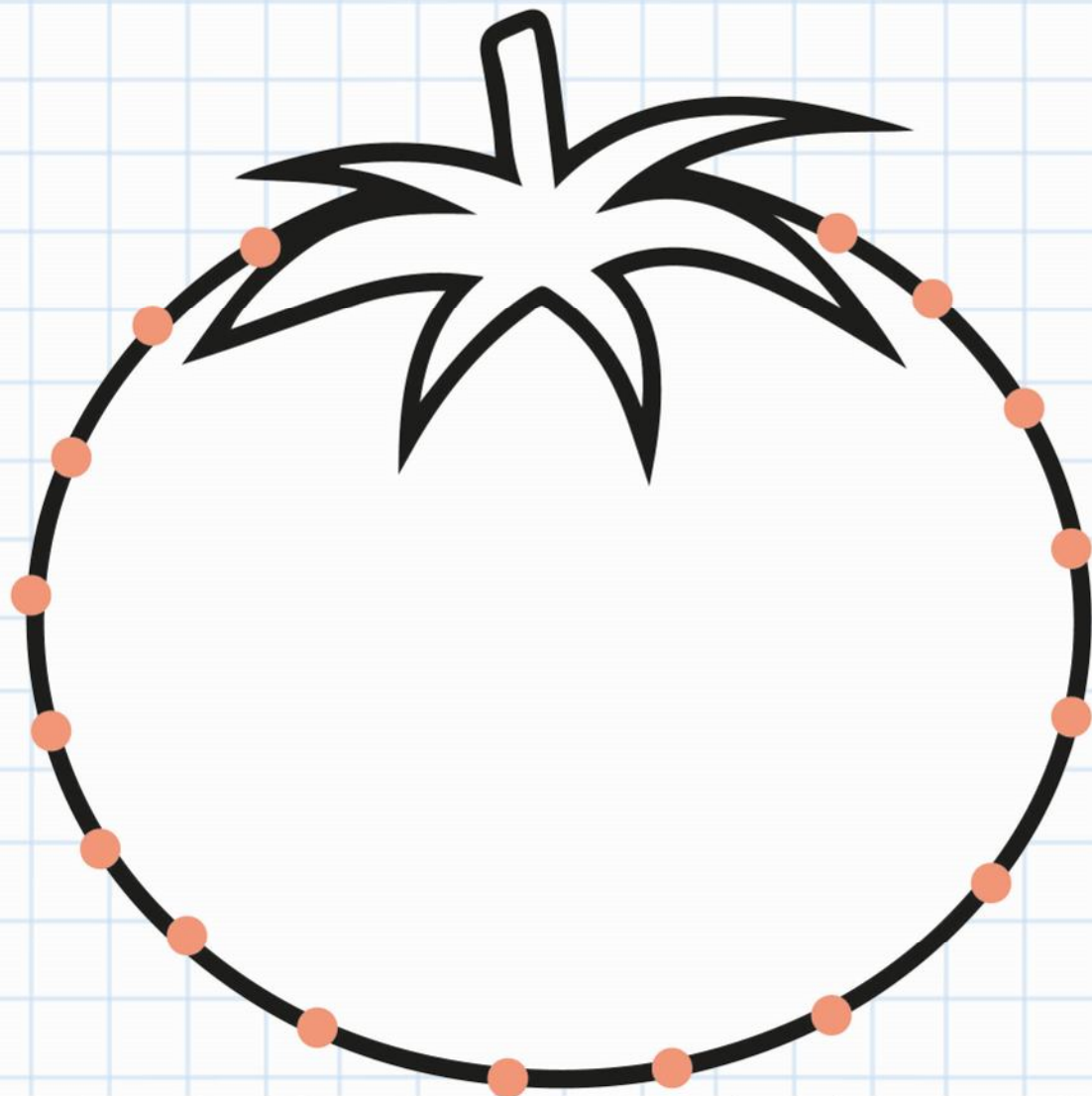



Mi nombre es: \_\_\_\_\_



# Circulo

❖ Pinta el círculo con crayola de color rojo (●)

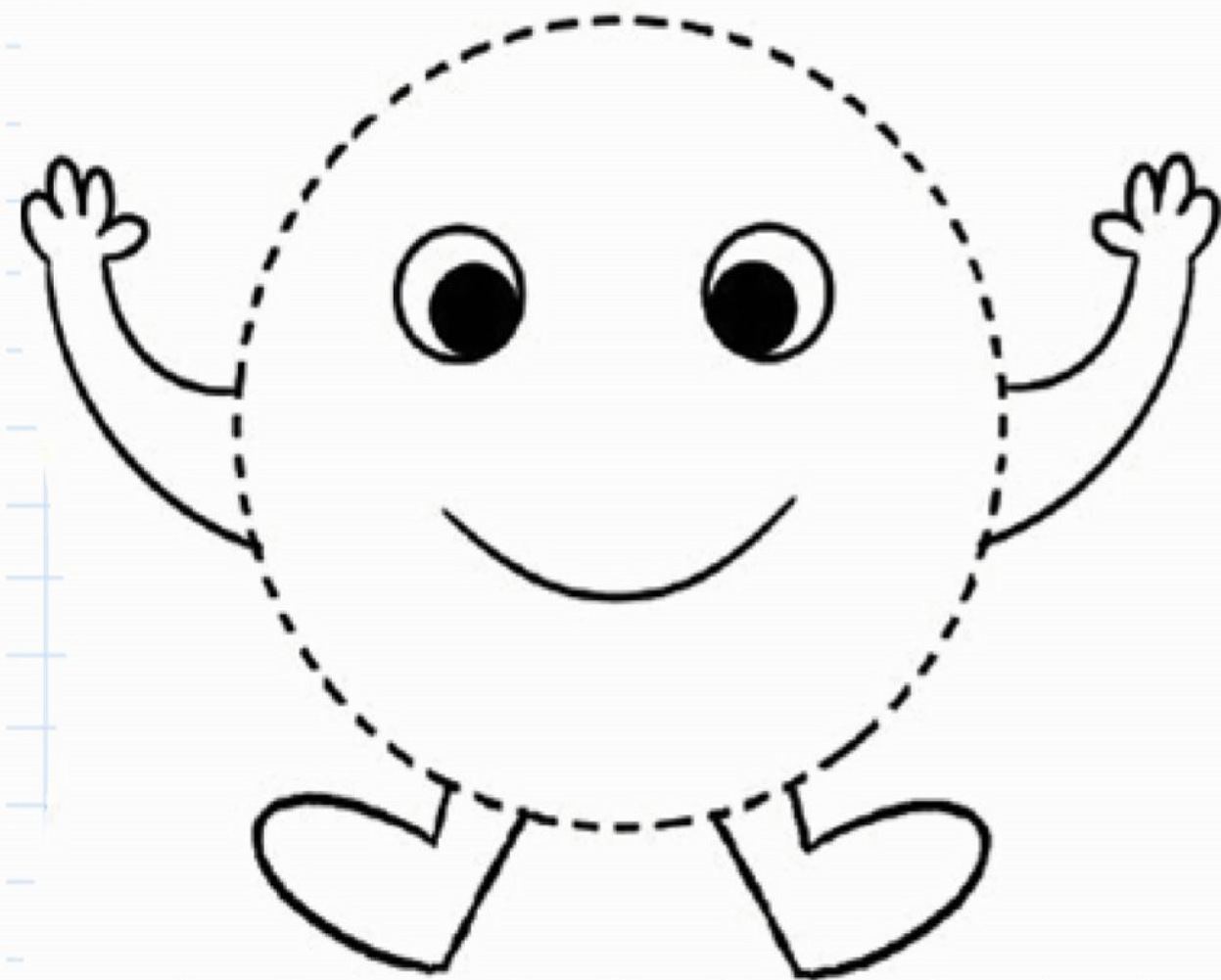

Soy el círculo.  
Repasa mi exterior y  
colorea mi interior.



Mi nombre es: \_\_\_\_\_

\_\_\_\_\_

❖ Pega bolitas de plastilina alrededor del círculo.

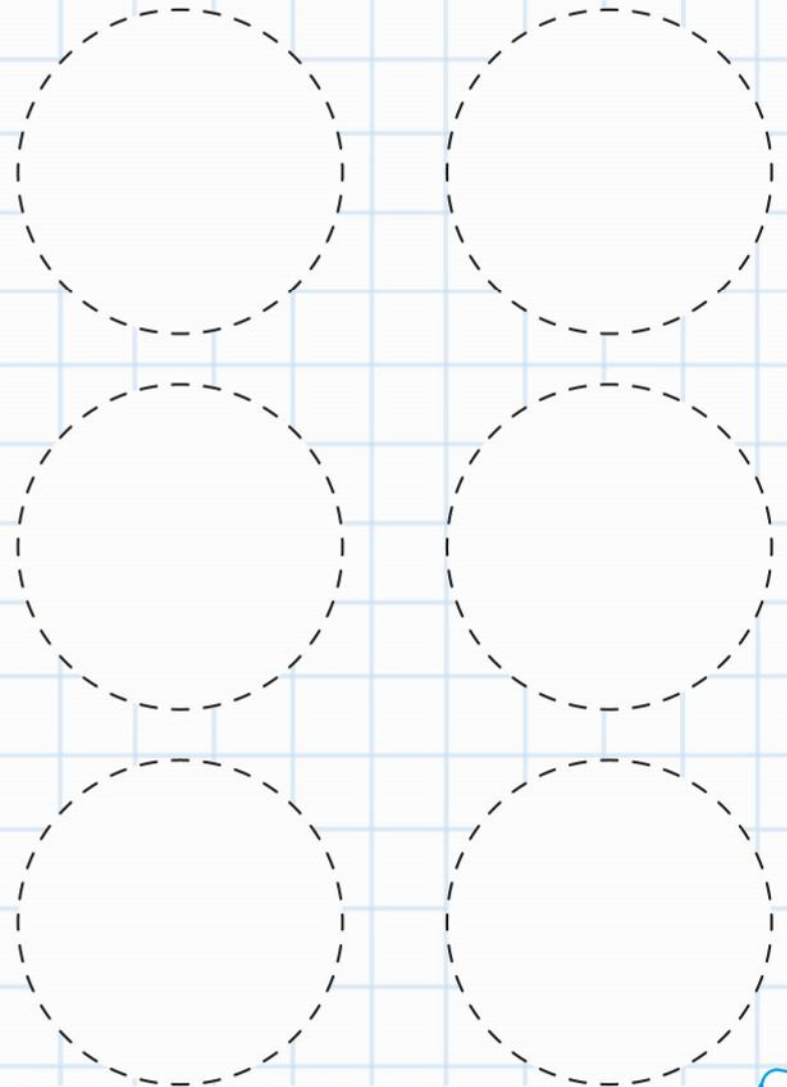
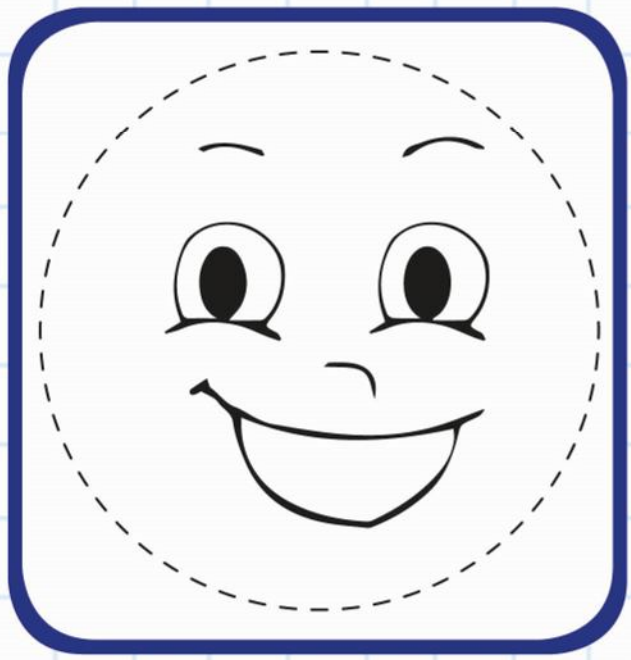



Mi nombre es: \_\_\_\_\_

\_\_\_\_\_



Pinta con tempera los círculos de color rojo (●).

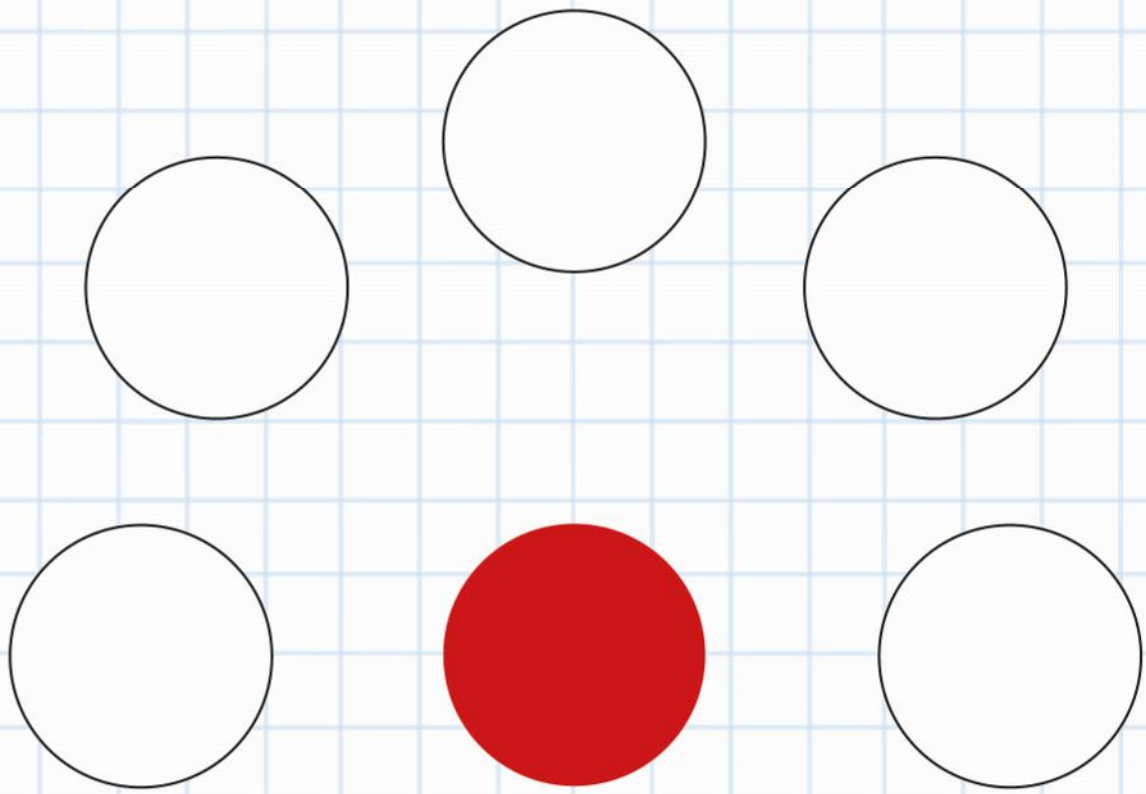
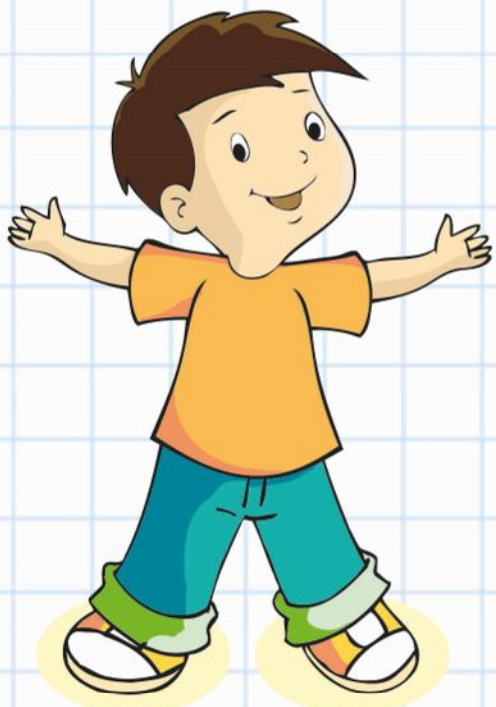



Mi nombre es: \_\_\_\_\_

--	--	--

❖ Deja tus huellitas con t mpera por los c rculos de color rojo.

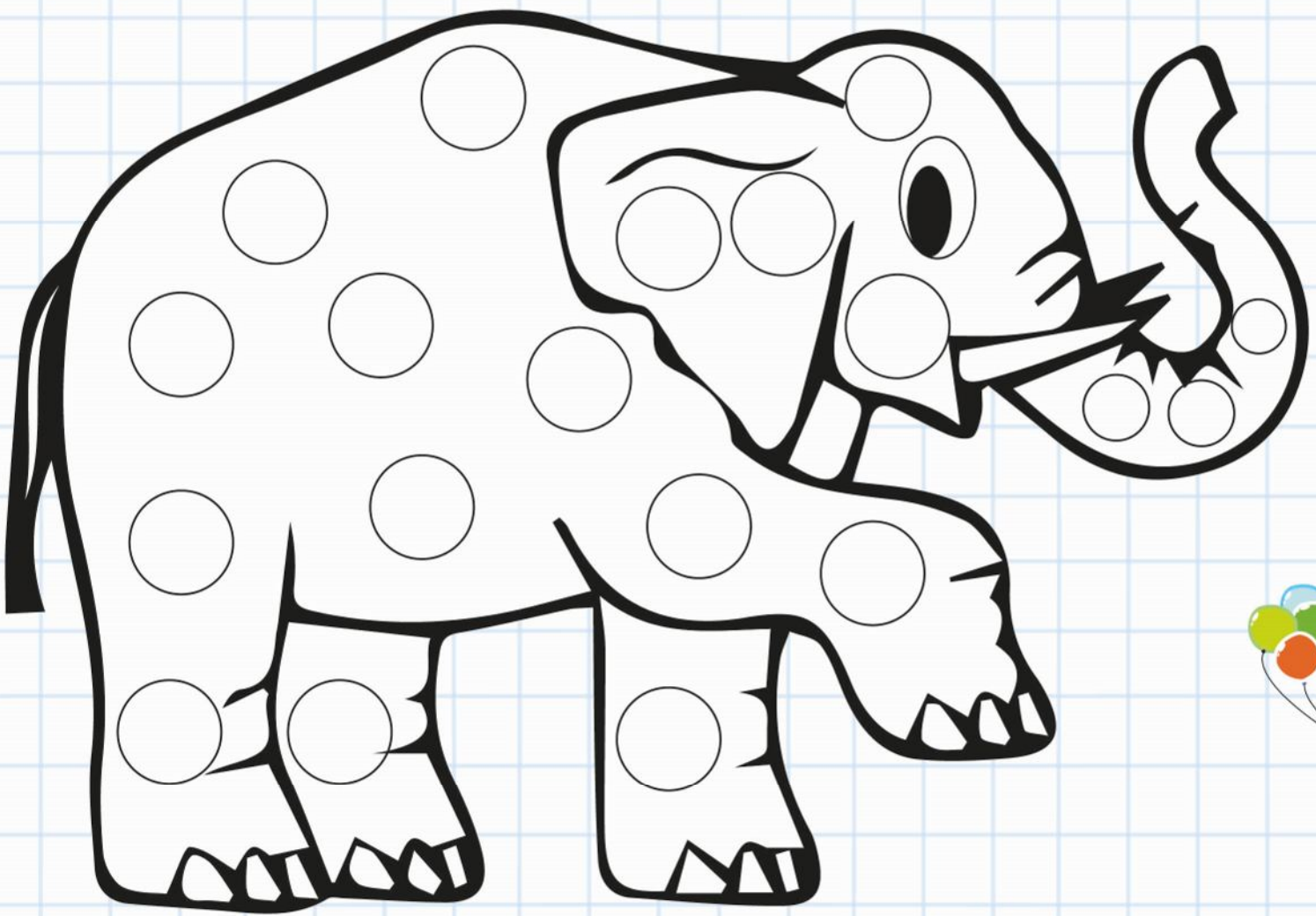



Mi nombre es: \_\_\_\_\_

\_\_\_\_\_



Marca con un aspa los gráficos que tengan forma de un círculo.

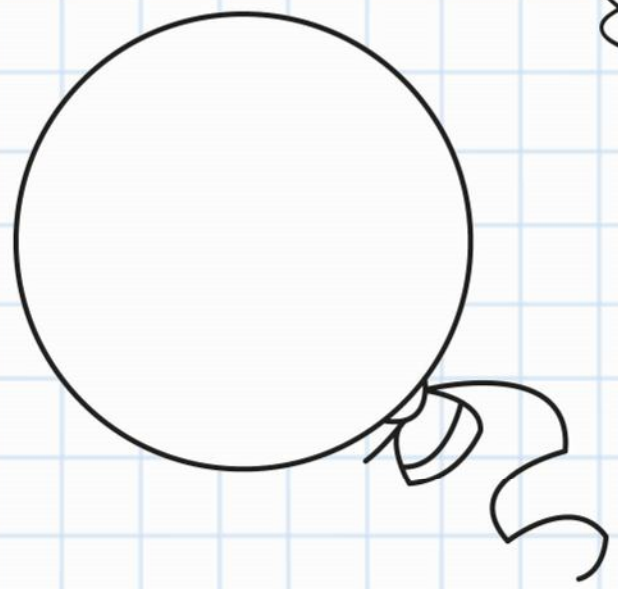





Mi nombre es: \_\_\_\_\_



# Arriba - Abajo

❖ Marca con una (X) las manzanas que están arriba del árbol y encierra en un círculo (O) las manzanas que están abajo del árbol.

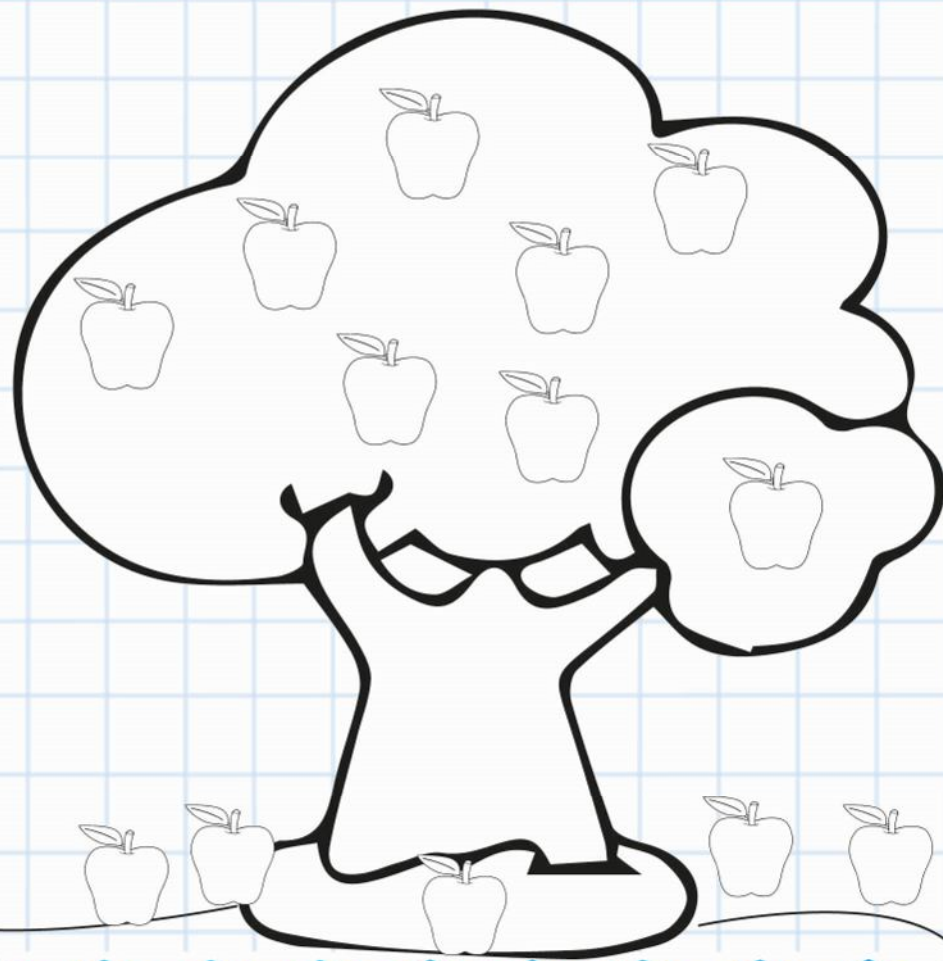



Mi nombre es: \_\_\_\_\_

--	--	--



Imita las acciones del niño con guía de tu profesora.

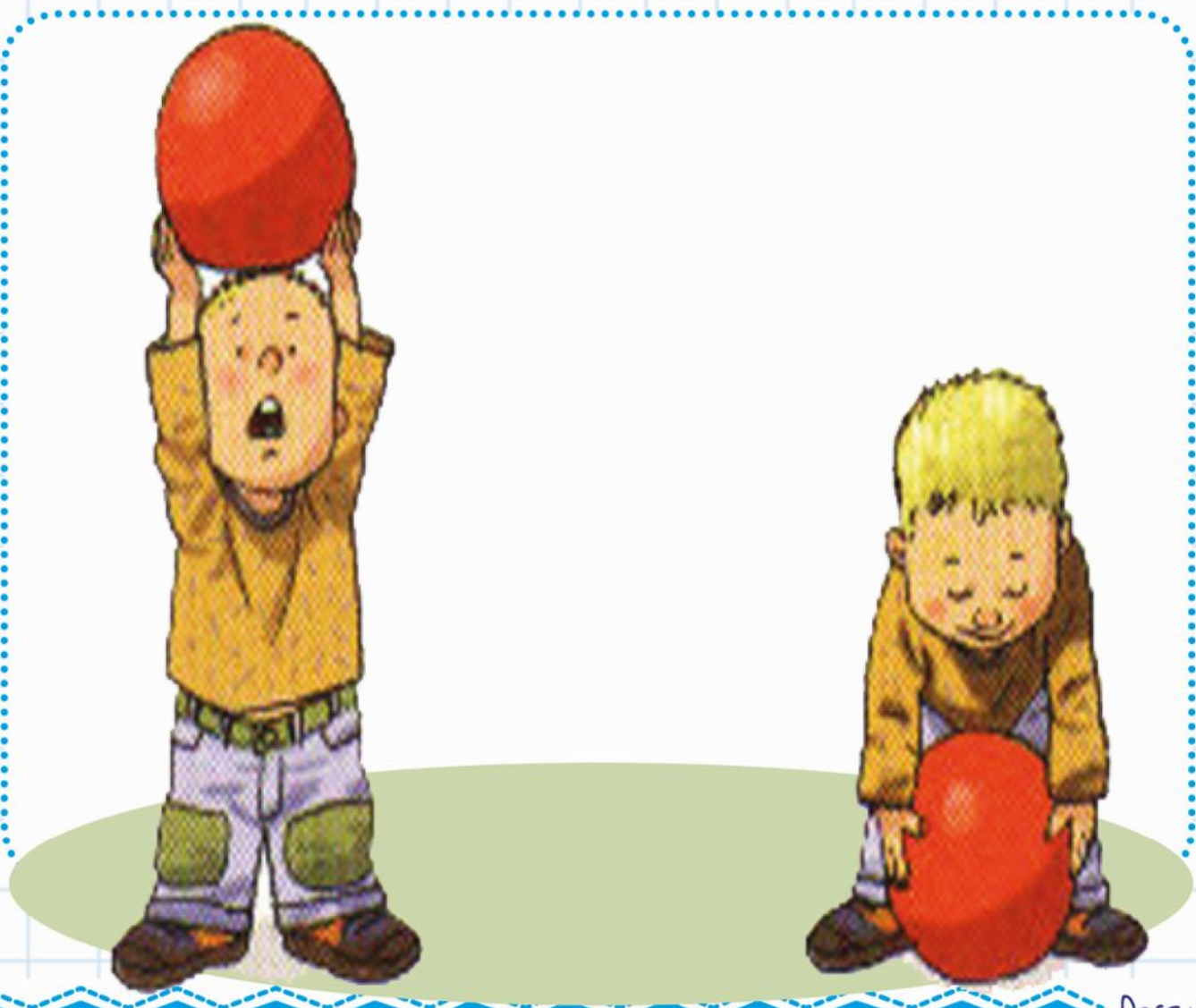



Mi nombre es: \_\_\_\_\_

\_\_\_\_\_



Encierra los aviones que están abajo y colorea los que están arriba.

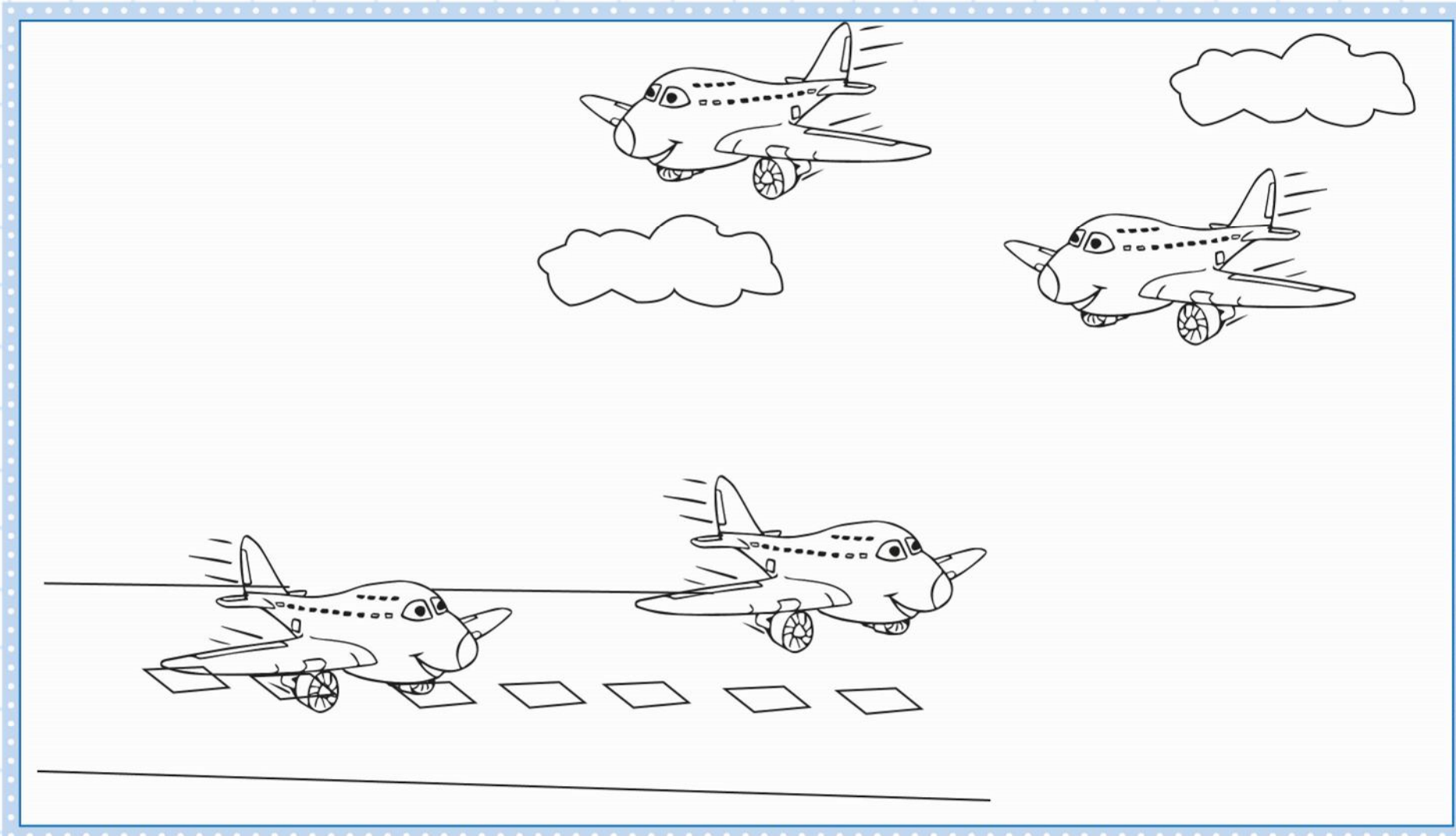



Mi nombre es: \_\_\_\_\_

--	--	--

# Dentro – Fuera

Pega plastilina al rededor de la niña que está afuera de la casa.





Mi nombre es: \_\_\_\_\_

--	--	--

❖ Colorea el gato que está dentro de la canasta.





Mi nombre es: \_\_\_\_\_



# Color azul

❖ Deja tus huellitas con t mpera azul en el carro.

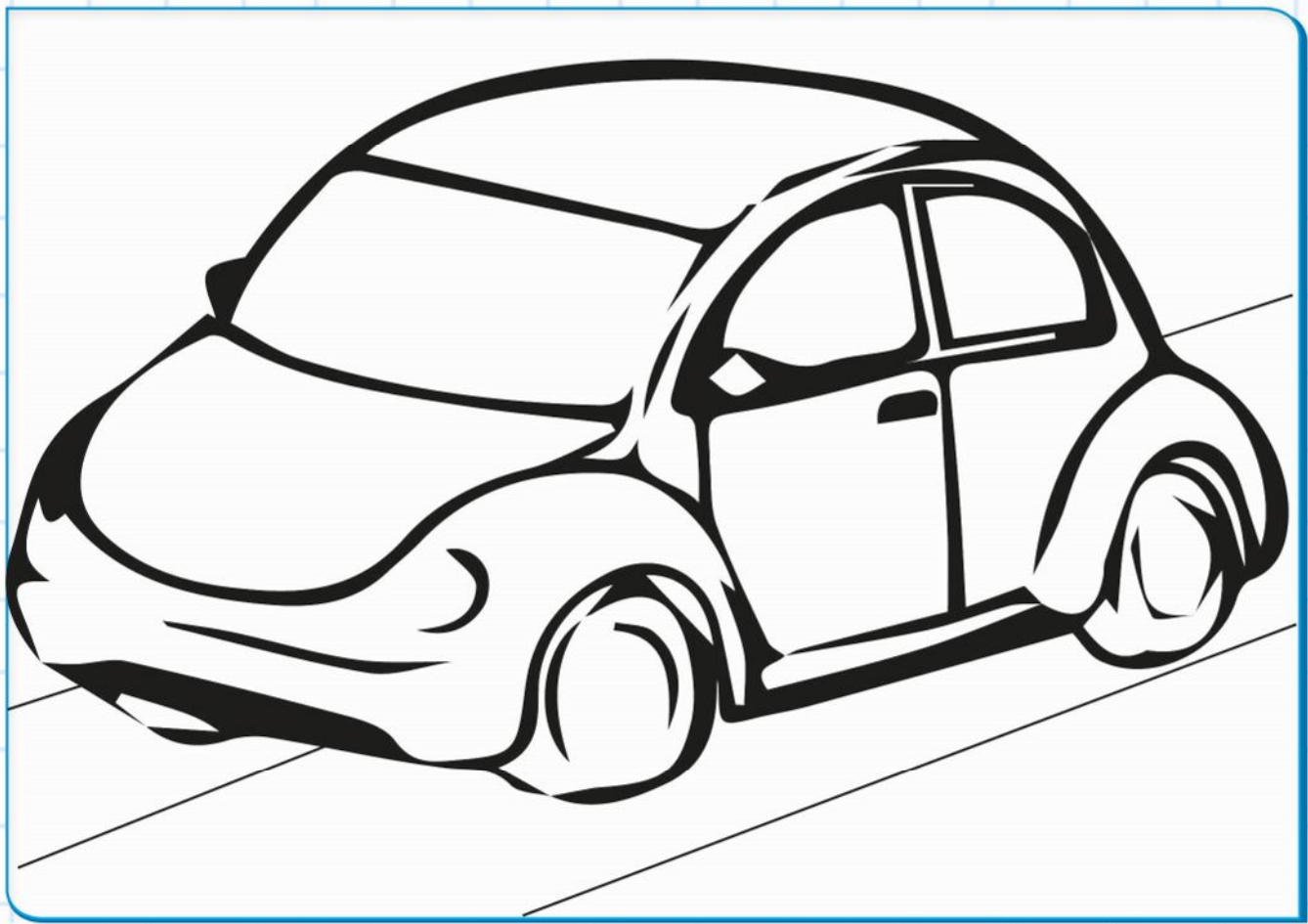



Mi nombre es: \_\_\_\_\_

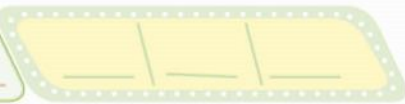

❖ Colorea el short de color azul.





Mi nombre es: \_\_\_\_\_

\_\_\_\_\_

# Grande - Pequeño

❖ Colorea al animalito que es más grande y marca (X) el más pequeño.

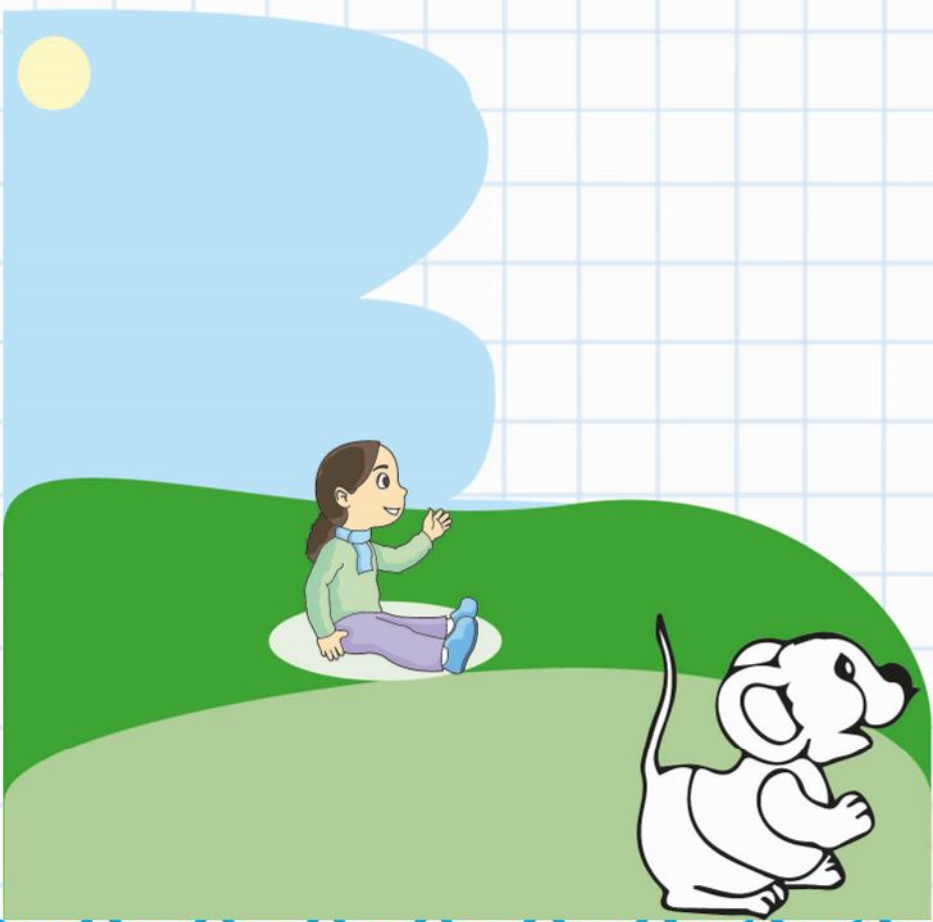





Mi nombre es: \_\_\_\_\_

--	--	--

Pega plastilina en el caracol grande.





Mi nombre es: \_\_\_\_\_

--	--	--

Marca (X) la sandía pequeña y pinta la grande.

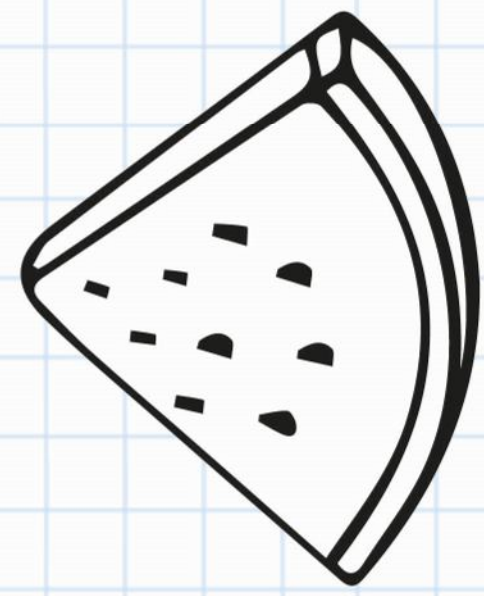
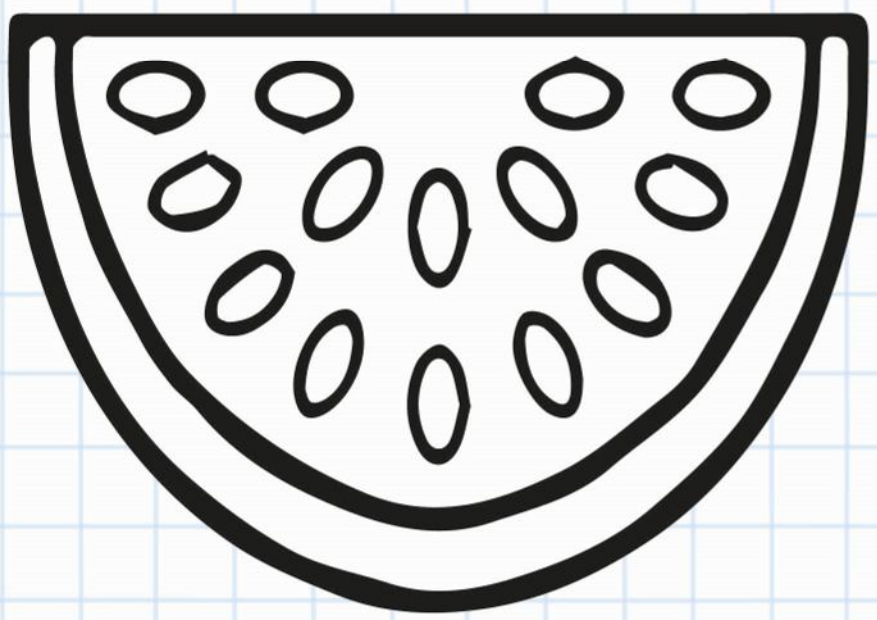

1 2 3 4 5 6 7 8 9 10 11 12 13 14 15 16 17 18 19 20 21 22 23 24 25 26 27 28 29 30 31 32 33 34 35 36 37 38 39 40 41 42 43 44 45 46 47 48 49 50 51 52 53 54 55 56 57 58 59 60 61 62 63 64 65 66 67 68 69 70 71 72 73 74 75 76 77 78 79 80 81 82 83 84 85 86 87 88 89 90 91 92 93 94 95 96 97 98 99 100

Mi nombre es: 

# Encima - Debajo

Encierra a la niña que está encima de la mesa.

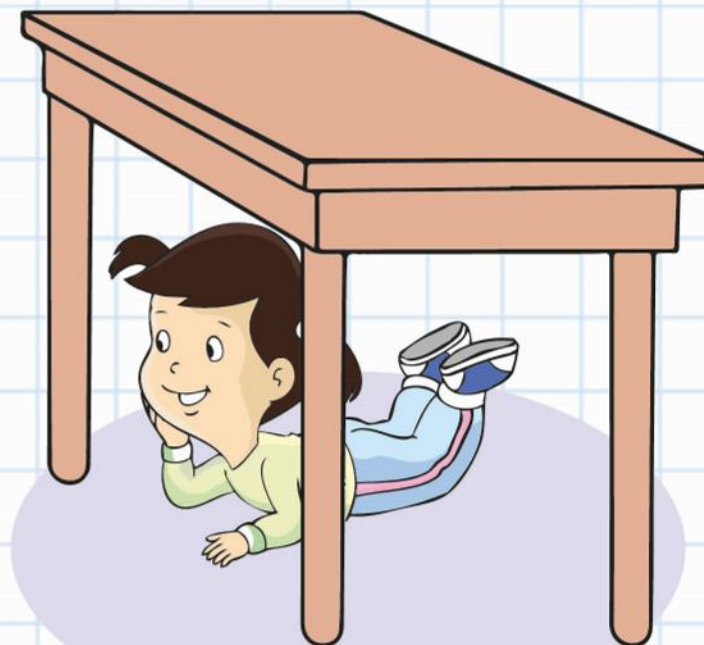
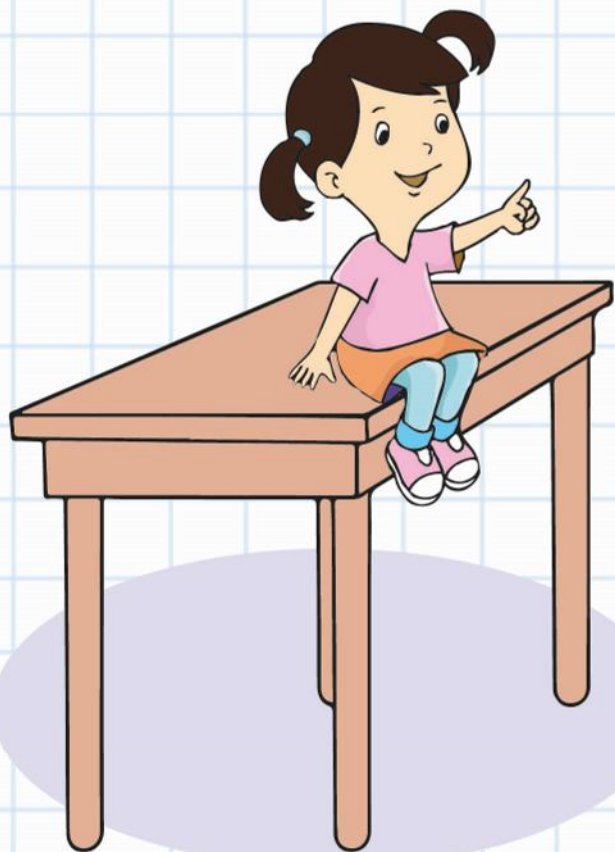



Mi nombre es: \_\_\_\_\_

--	--	--

Embolilla papel en la pelota que está abajo de la mesa y pinta la pelota que está encima.

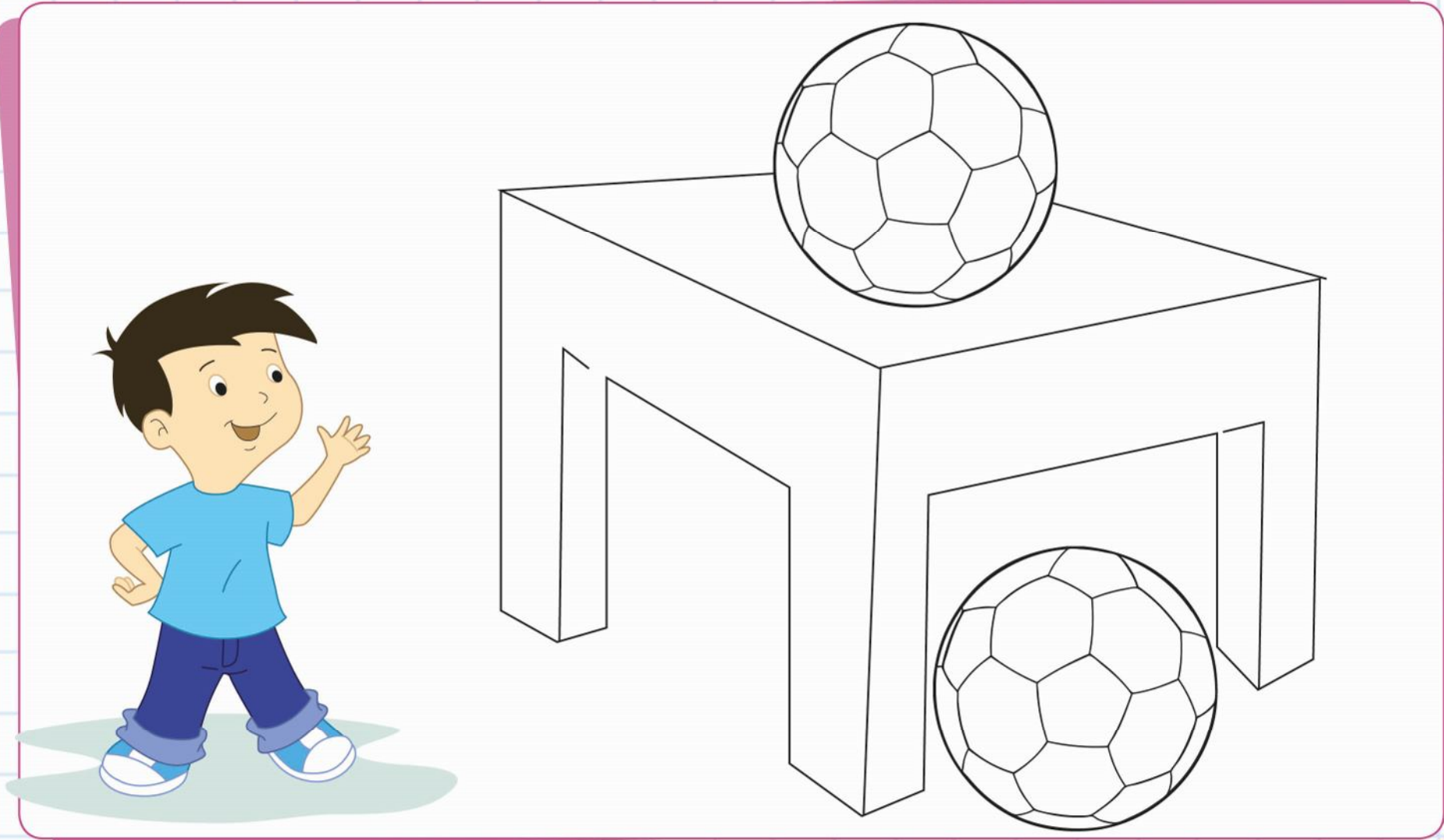



Mi nombre es: \_\_\_\_\_



❖ Colorea los trenes que están encima de la mesa.

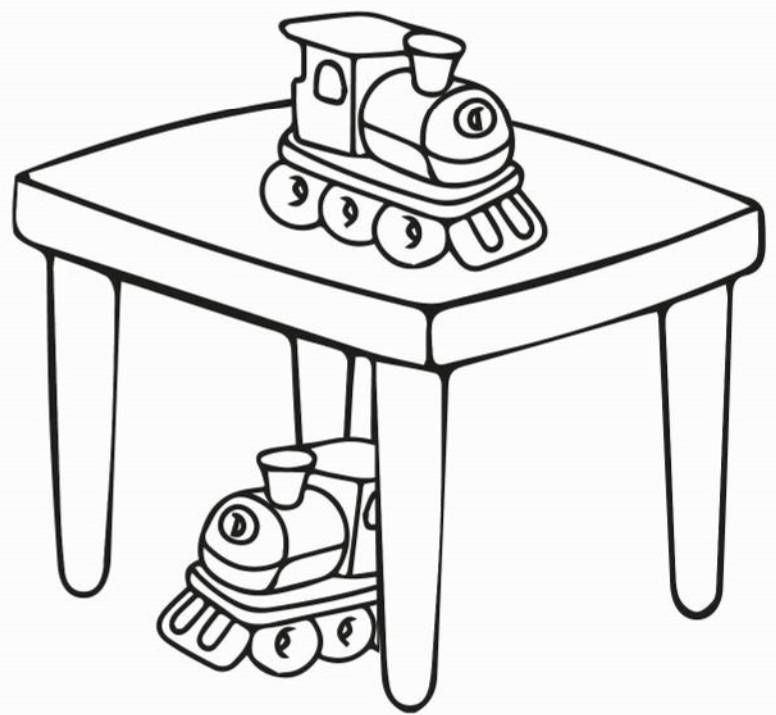
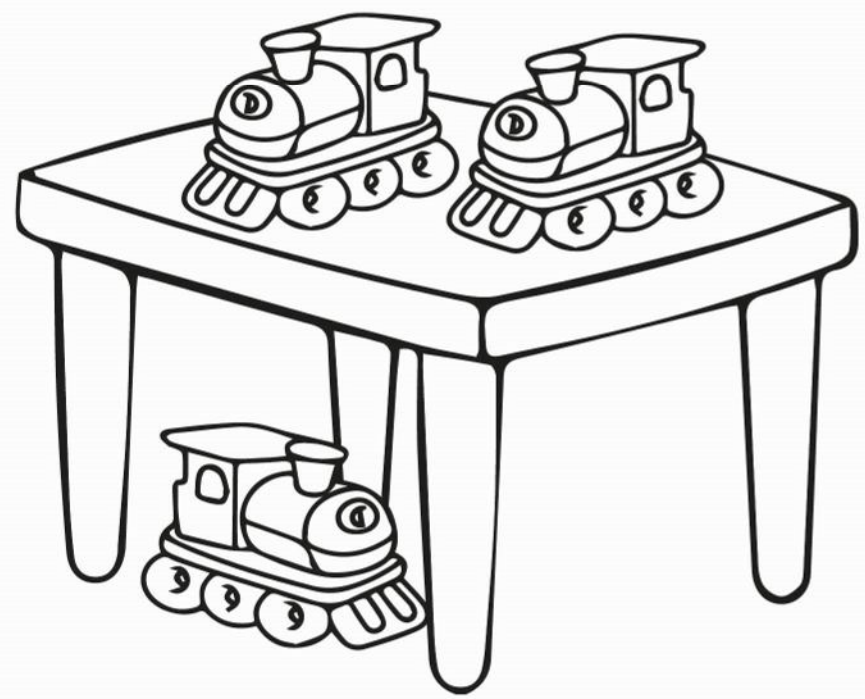



Mi nombre es: \_\_\_\_\_

--	--	--

# Abierta - Cerrada



Colorea la caja cerrada.

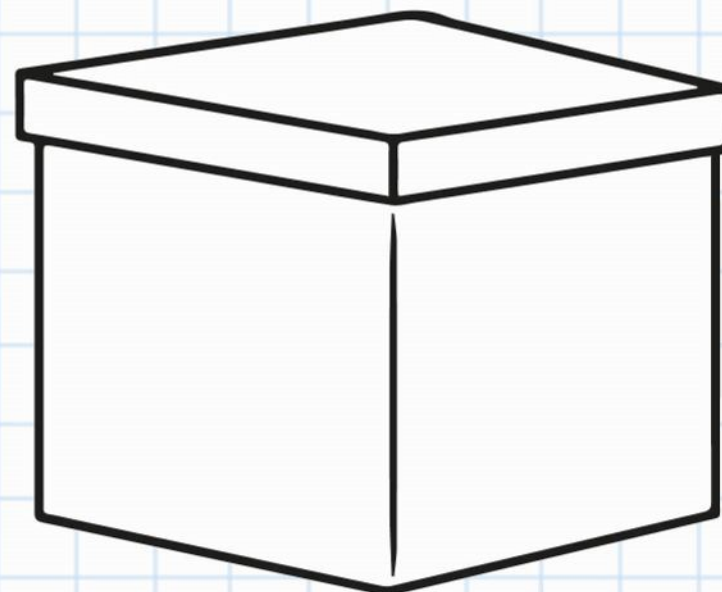
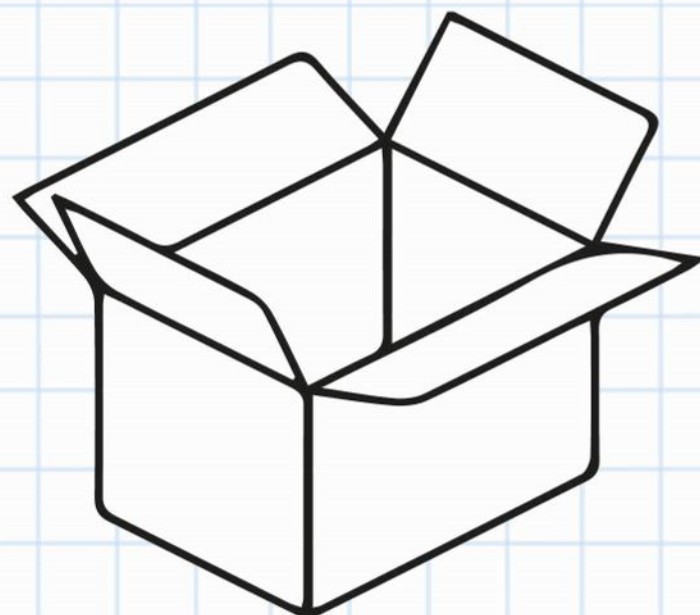



Mi nombre es: \_\_\_\_\_

\_\_\_\_\_

❖ Pega serpentina al borde de la puerta abierta y marca (X) la puerta cerrada.

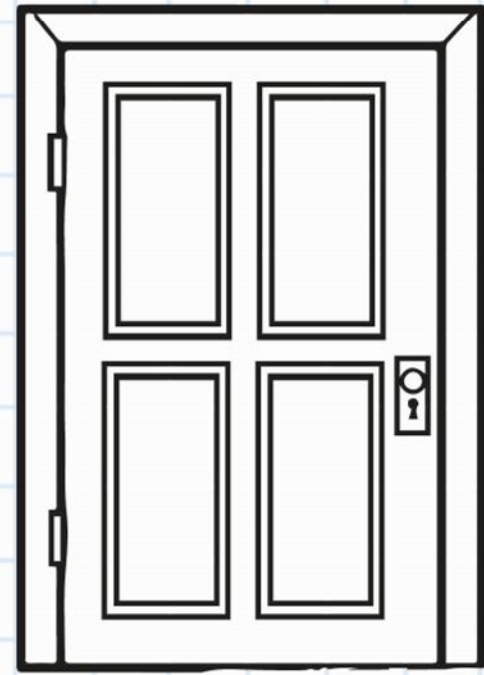
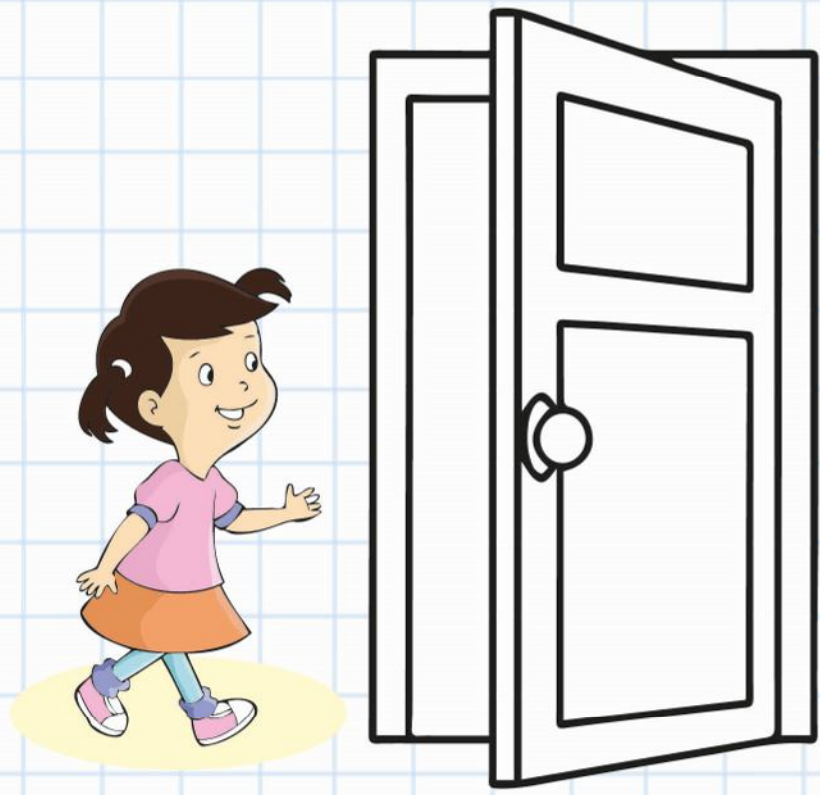



Mi nombre es: \_\_\_\_\_

--	--	--



Pinta el libro que está abierto.

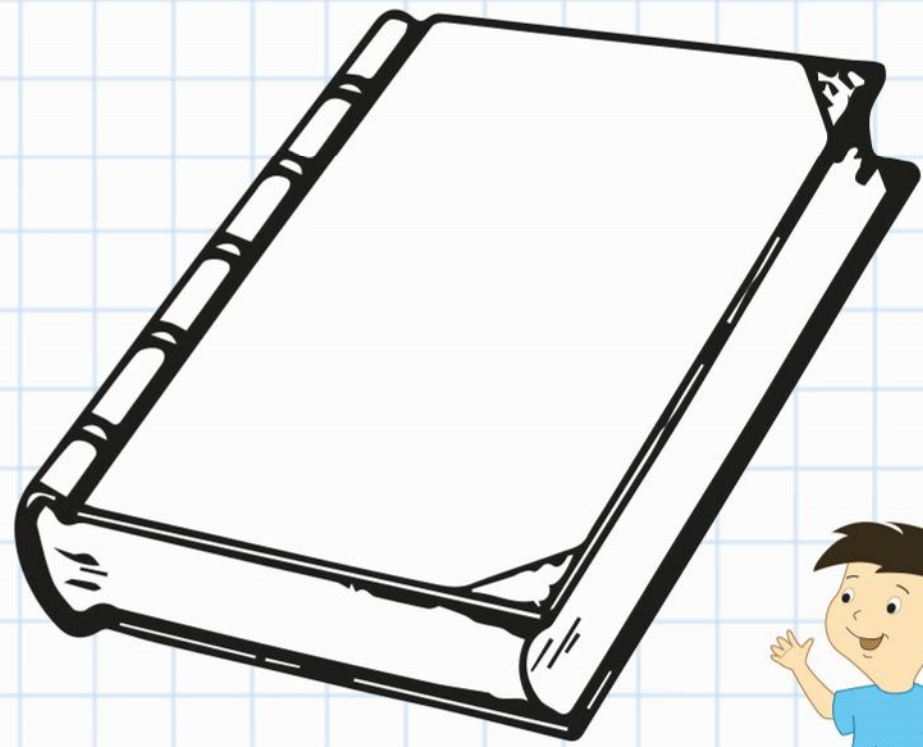
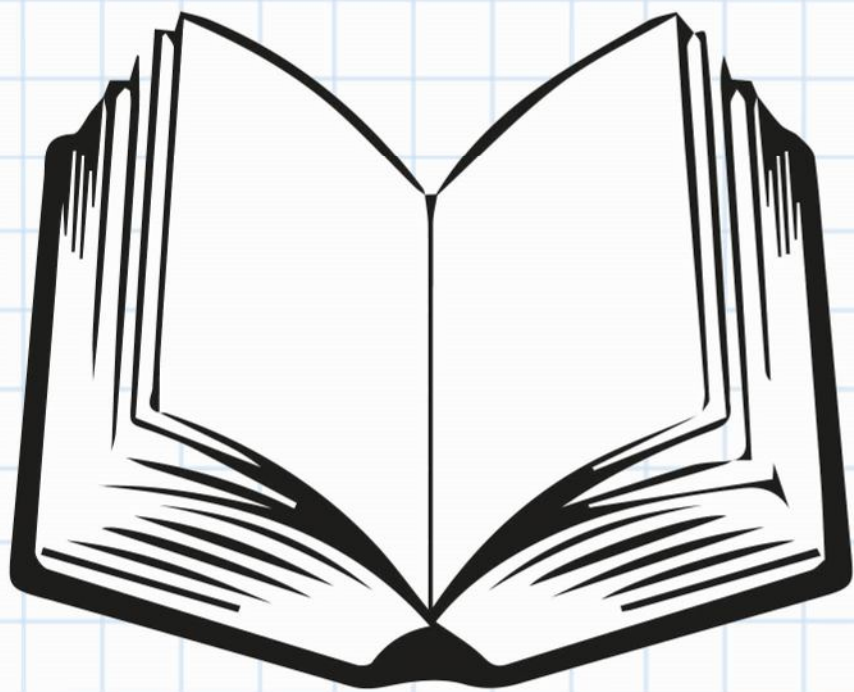





Mi nombre es: \_\_\_\_\_

\_\_\_\_\_

# Alto - Bajo



Colorea el animalito más alto de amarillo.

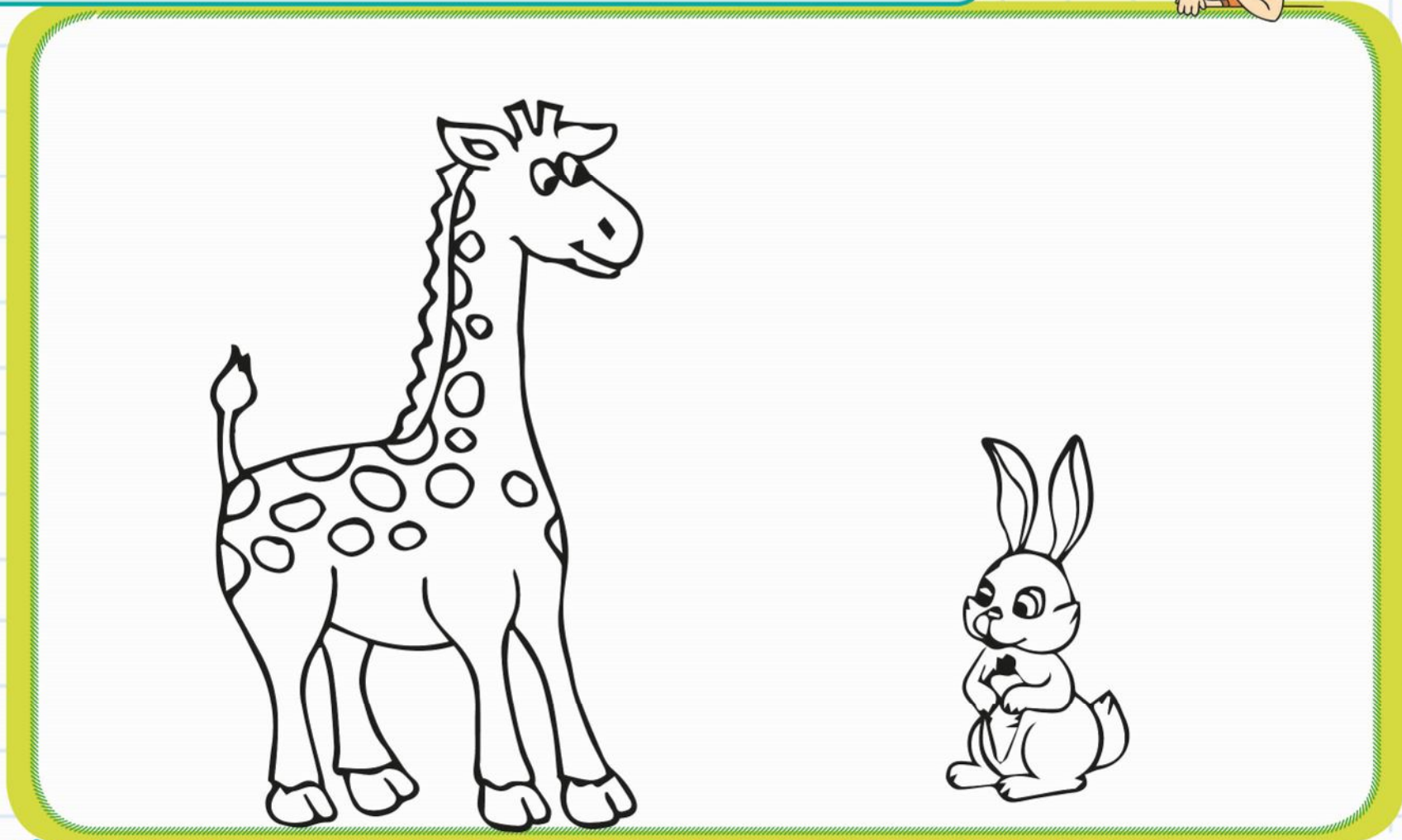



Mi nombre es: \_\_\_\_\_



❖ Rasga papel en el árbol bajo y encierra (O) el árbol alto.

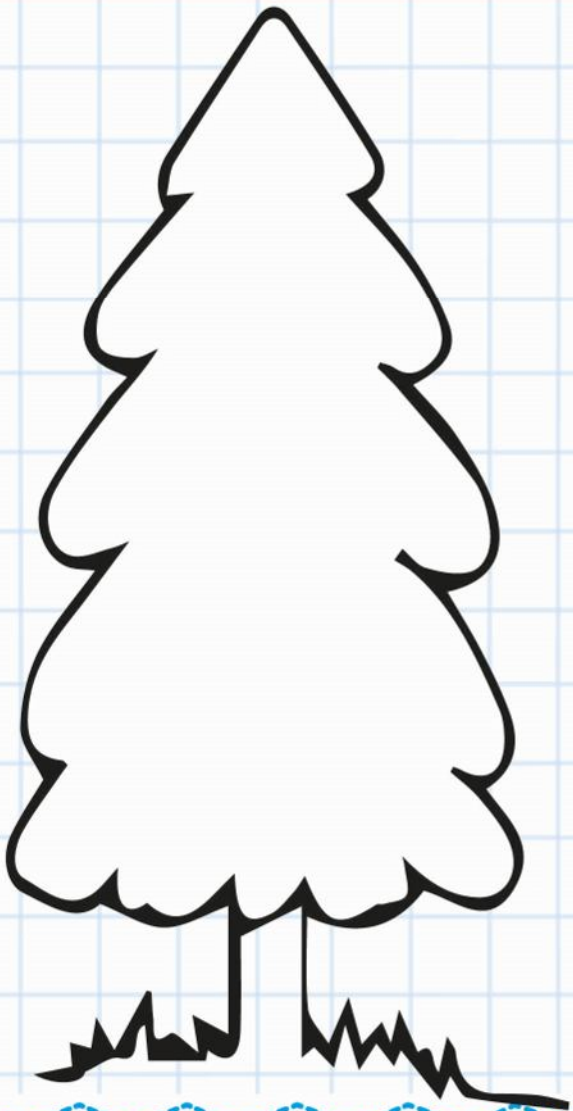



Mi nombre es: \_\_\_\_\_

--	--	--

❖ Encierra la persona más alta y colorea la persona más baja.

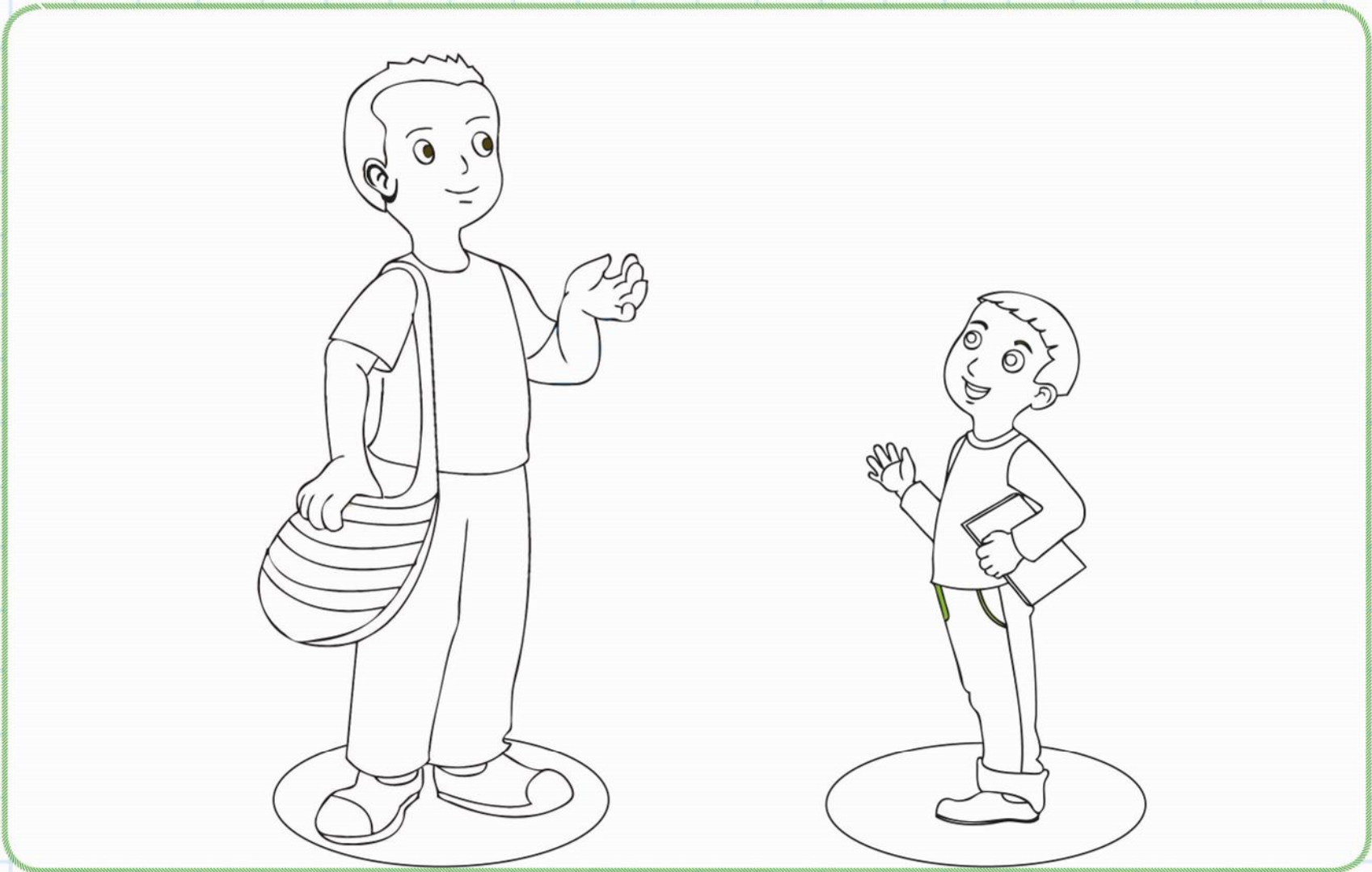



Mi nombre es: \_\_\_\_\_

--	--	--



Pega escarcha en la flor más alta.

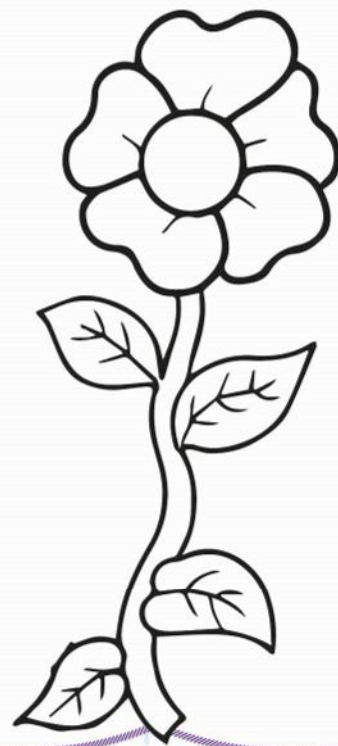
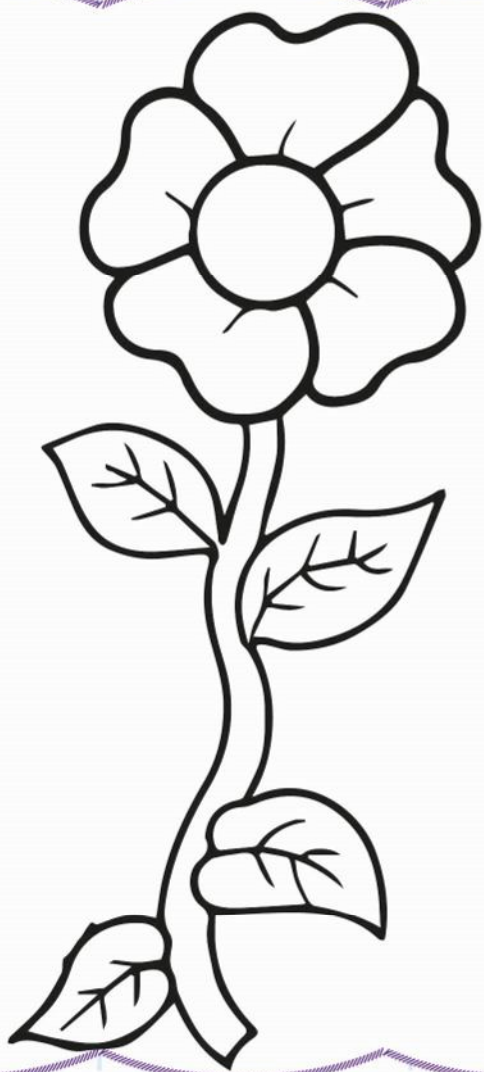



Mi nombre es: \_\_\_\_\_

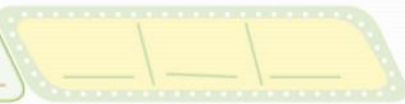

# El cuadrado

❖ Embolilla papel azul al borde del cuadrado.

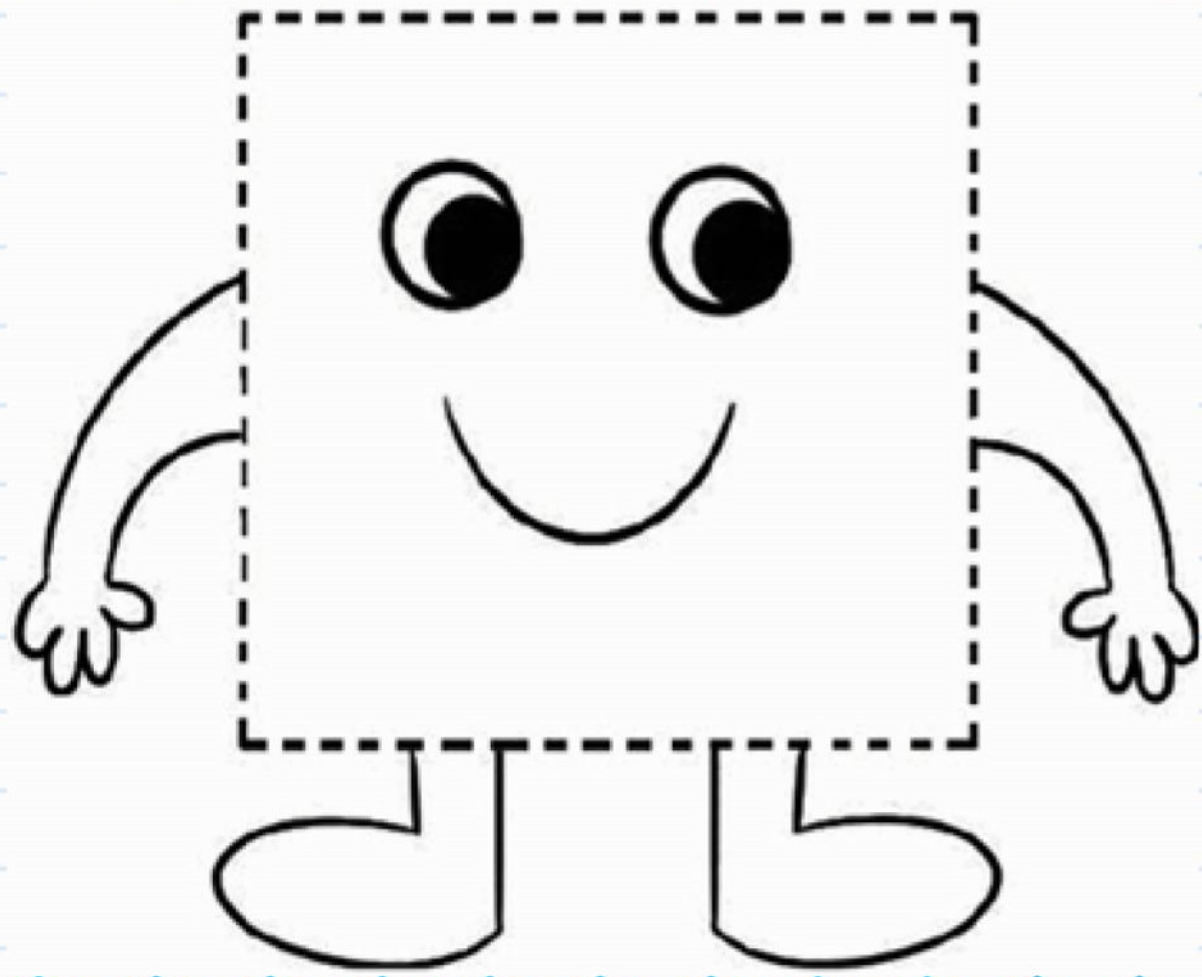

Soy el cuadrado.  
Repasa mis cuatro  
lados y coloréame.



Mi nombre es: \_\_\_\_\_

\_\_\_\_\_

❖ Traza el cuadrado con plumón.

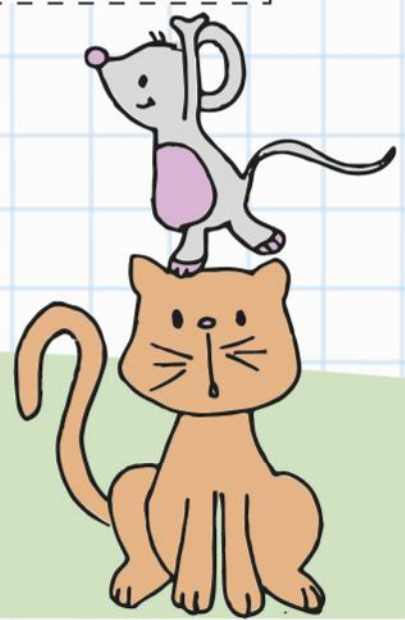
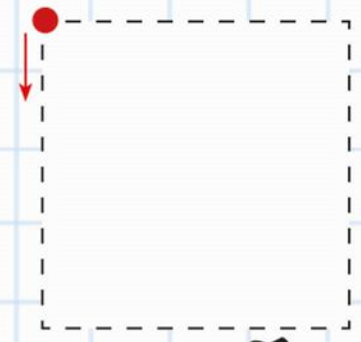
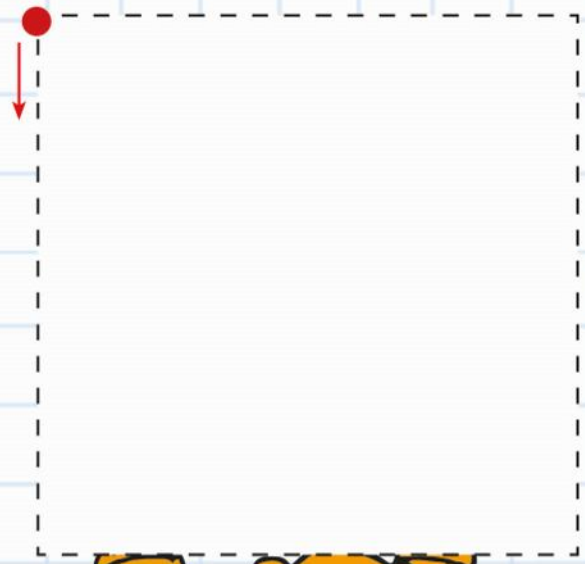



Mi nombre es: \_\_\_\_\_

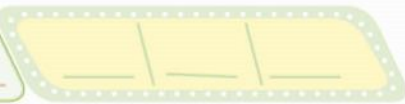

◆ Pinta los cuadrados.

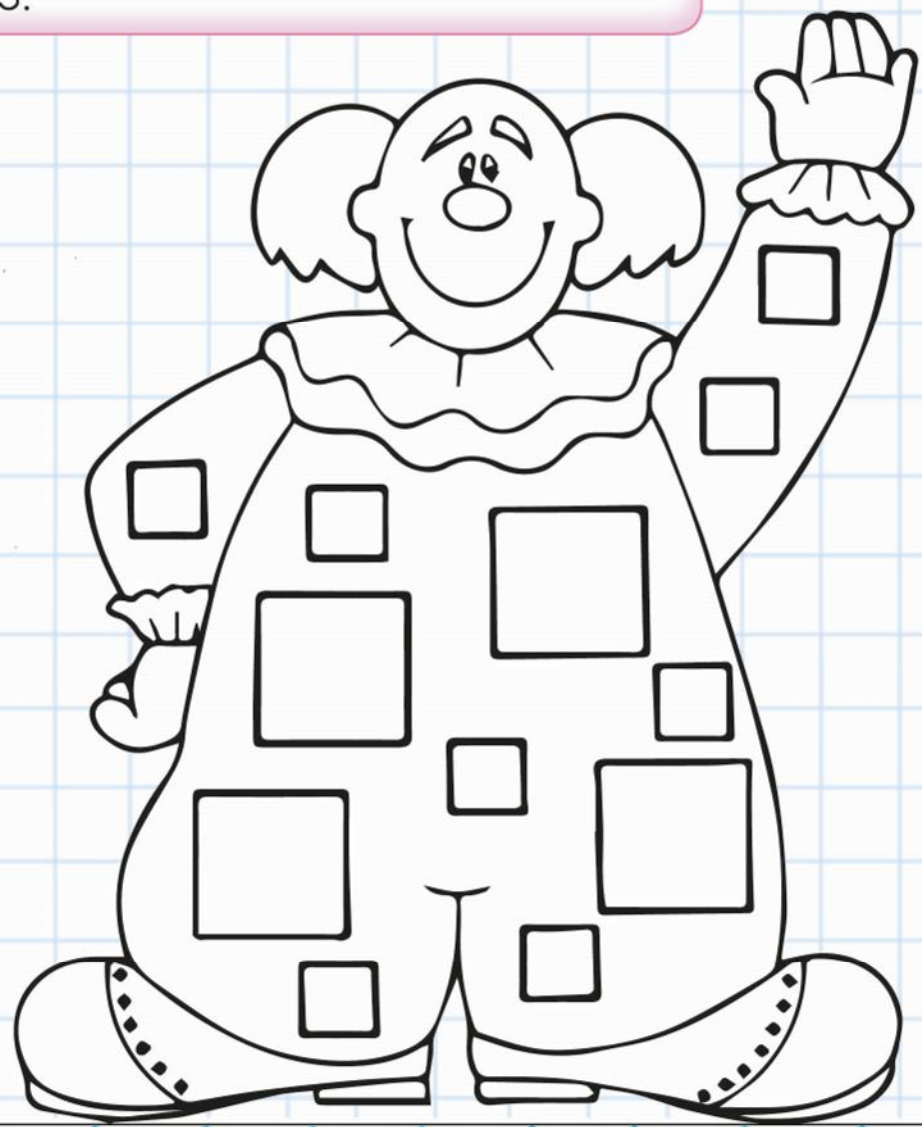



Mi nombre es: \_\_\_\_\_



# Color amarillo

◆ Deja tus huellitas con témpera amarilla dentro del pollito.

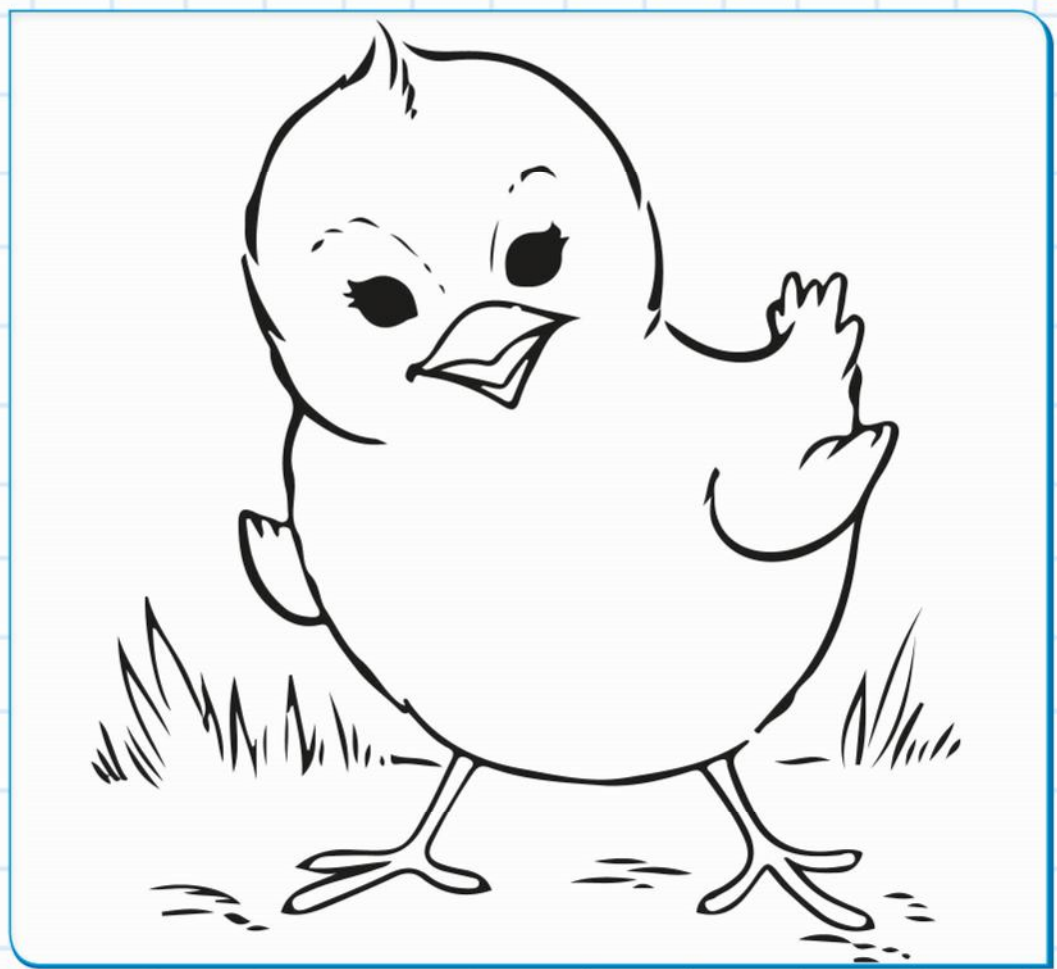





Mi nombre es: \_\_\_\_\_



◆ Rasga papel amarillo y pega en el Sol.

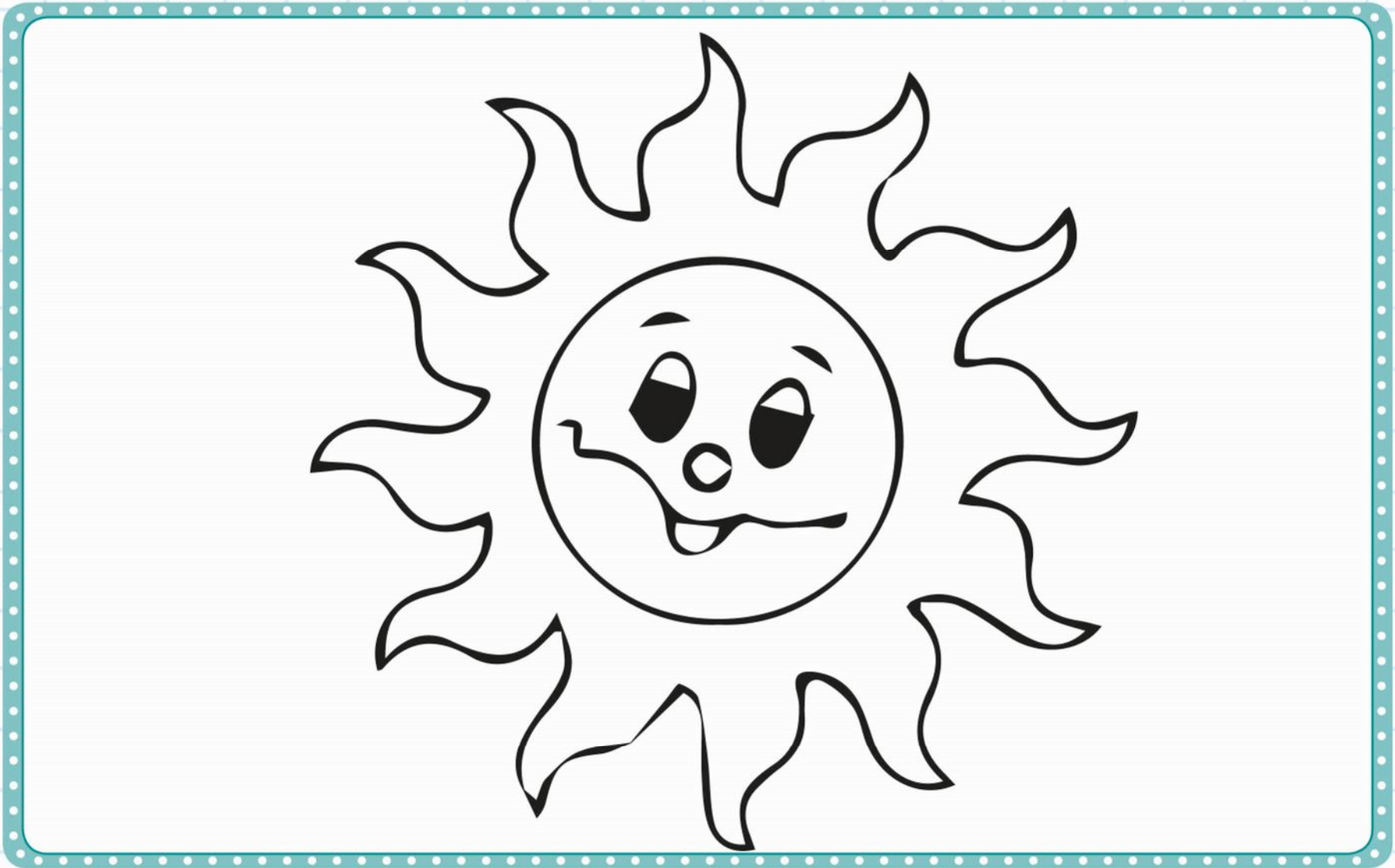



Mi nombre es: \_\_\_\_\_

\_\_\_\_\_

◆ Colorea el plátano de color amarillo con tempera.

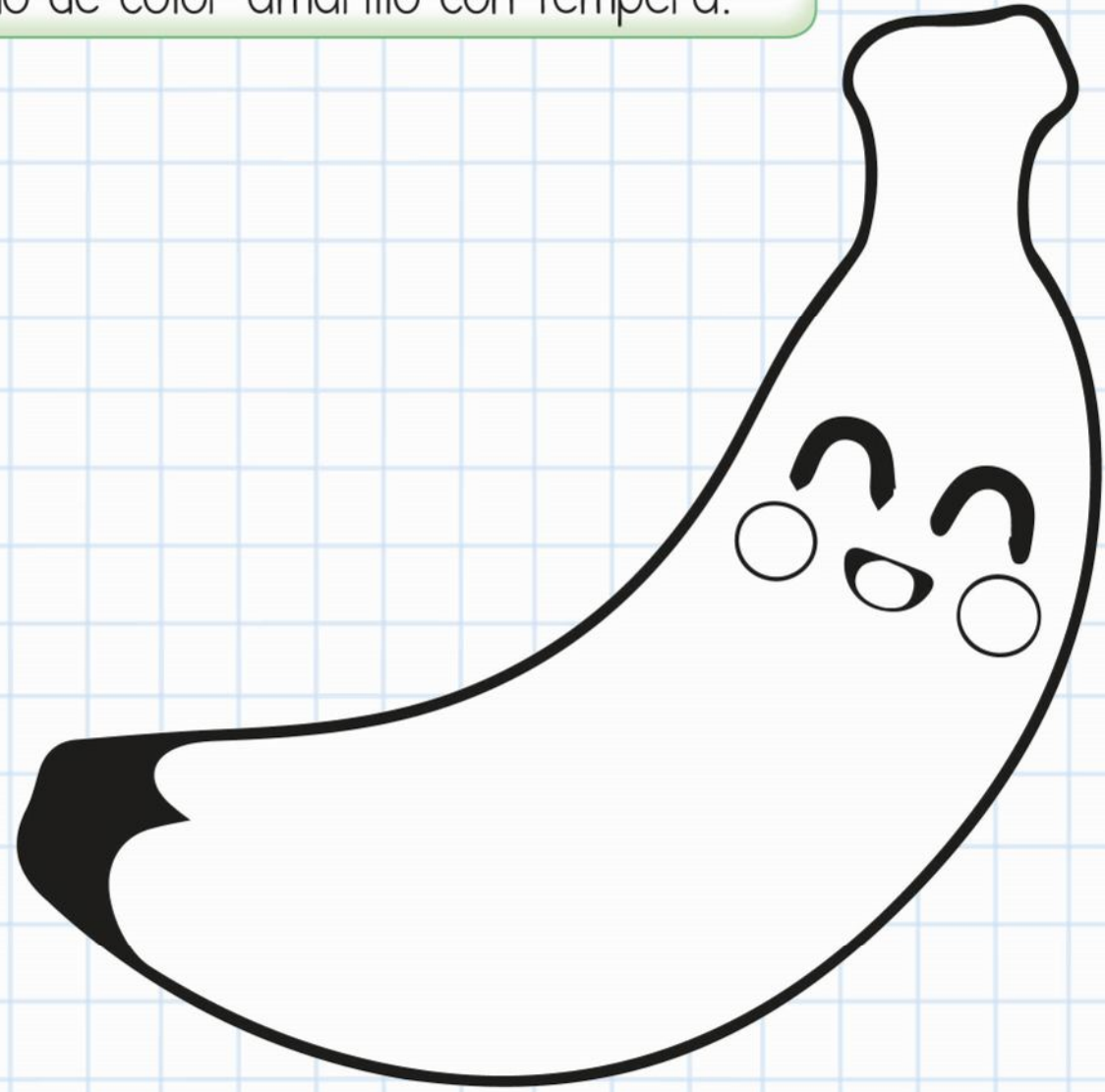
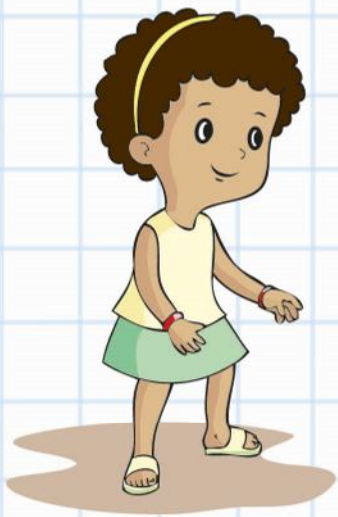



Mi nombre es: \_\_\_\_\_



# Junto - Separado

❖ Encierra y colorea a los niños que se encuentran juntos: luego marca (X), a los que se hallan separados del grupo.

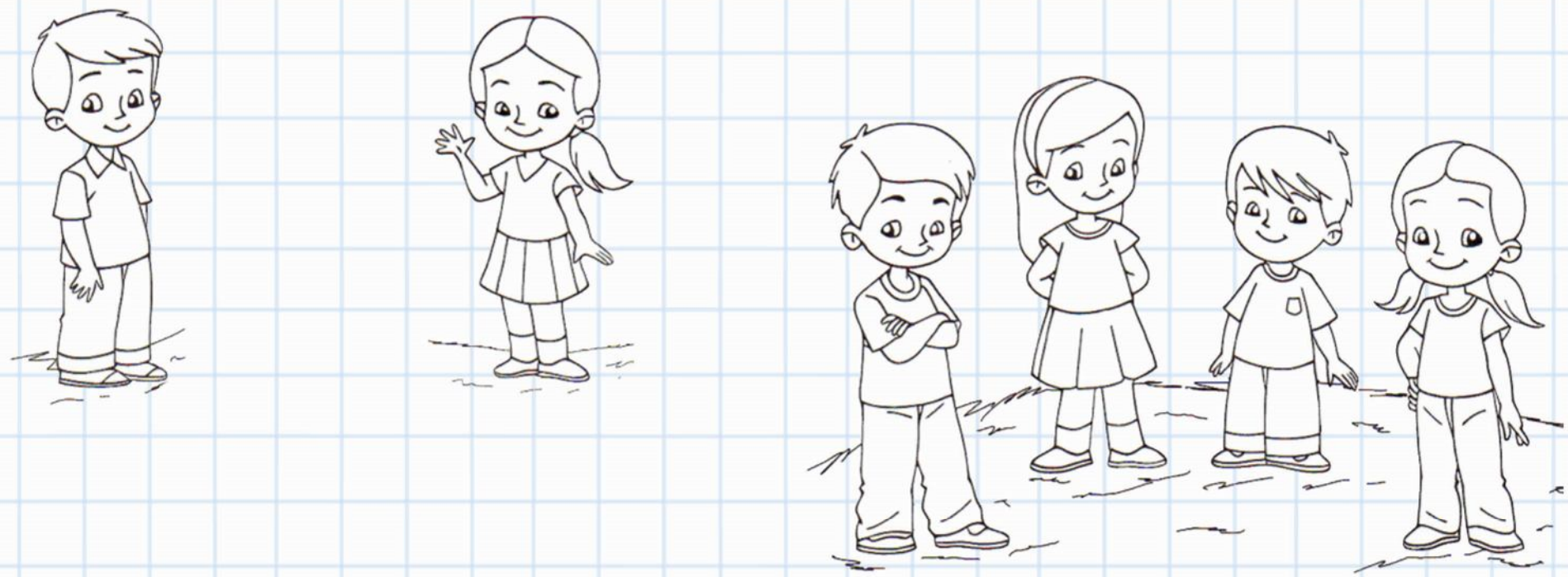



Mi nombre es: \_\_\_\_\_

\_\_\_\_\_



Embolilla y encierra los animalitos que están juntos.

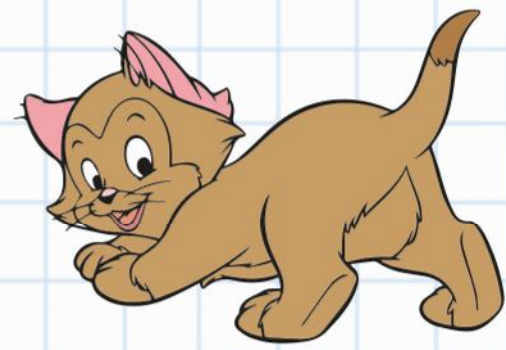
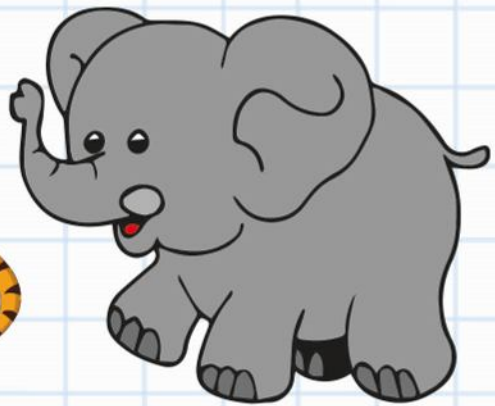



Mi nombre es: \_\_\_\_\_

\_\_\_\_\_



Colorea los pinceles separados y marca (X) los pinceles juntos.

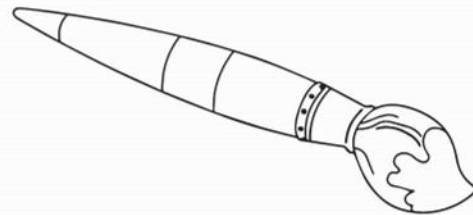
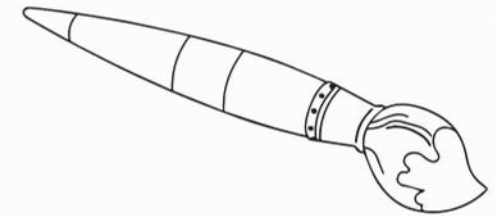
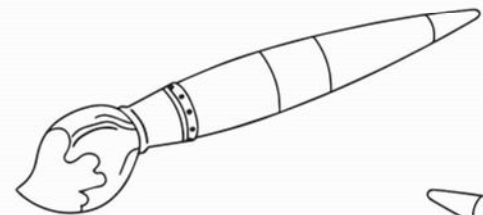
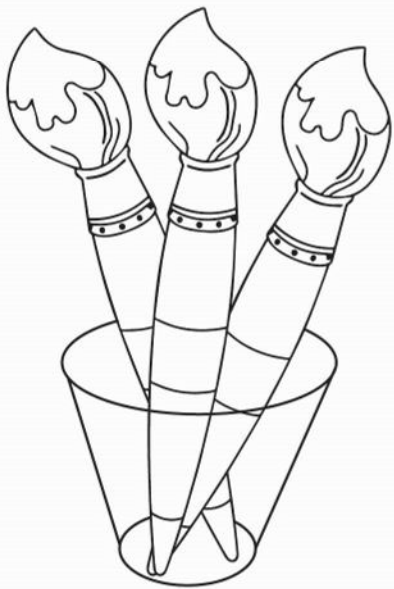



Mi nombre es: \_\_\_\_\_



# Muchos - Pocos

Marca (X) donde hay muchos niños.





Mi nombre es: \_\_\_\_\_

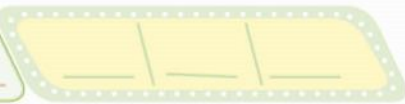

❖ Encierra con plastilina alrededor, donde hay pocas abejas.

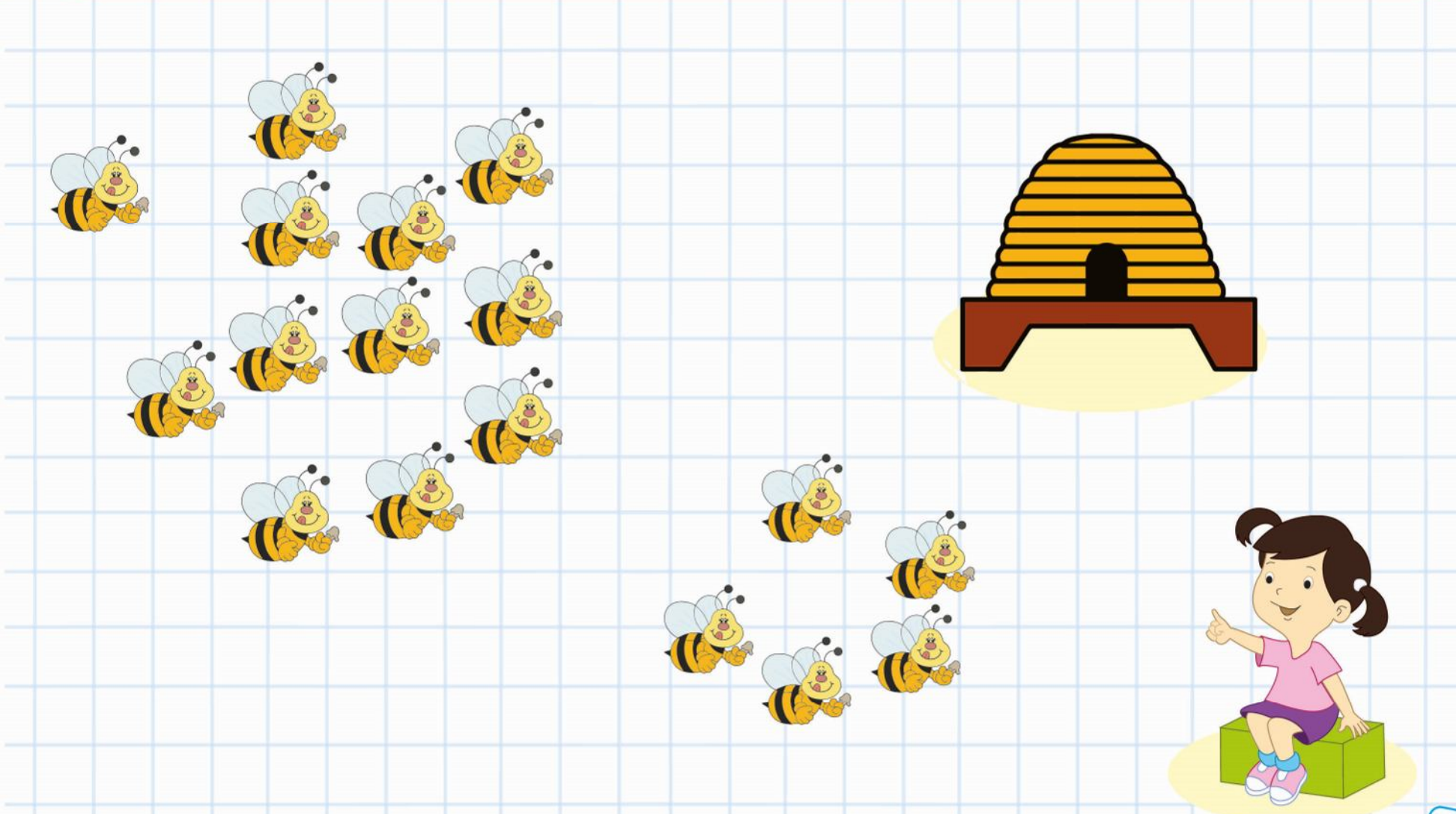



Mi nombre es: \_\_\_\_\_

\_\_\_\_\_



Colorea donde hay muchas paletas.

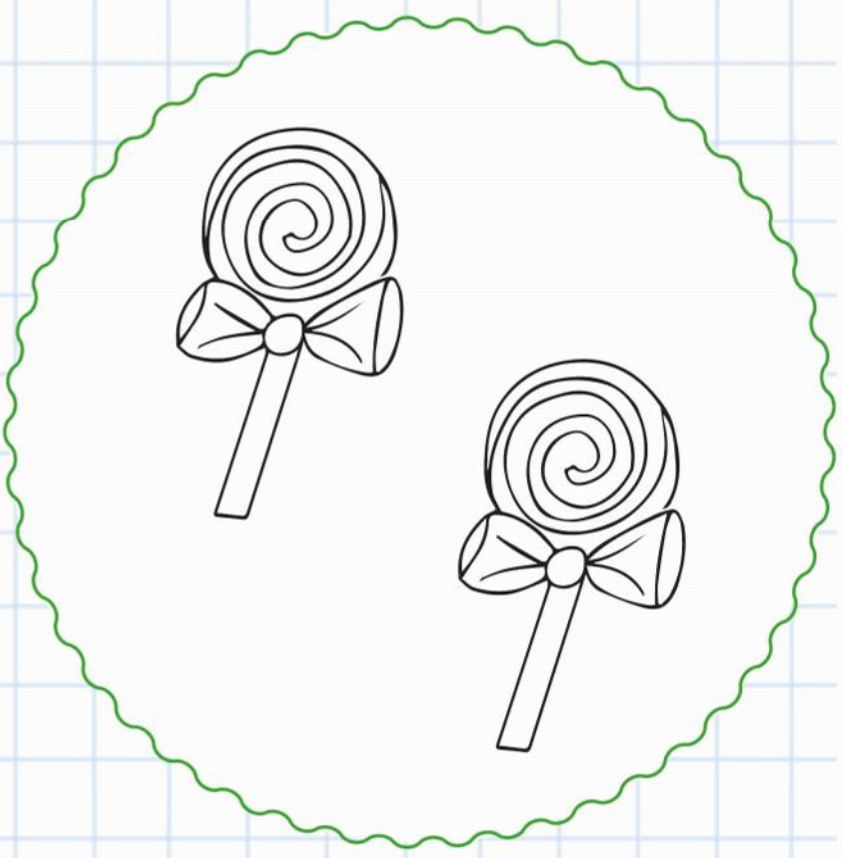
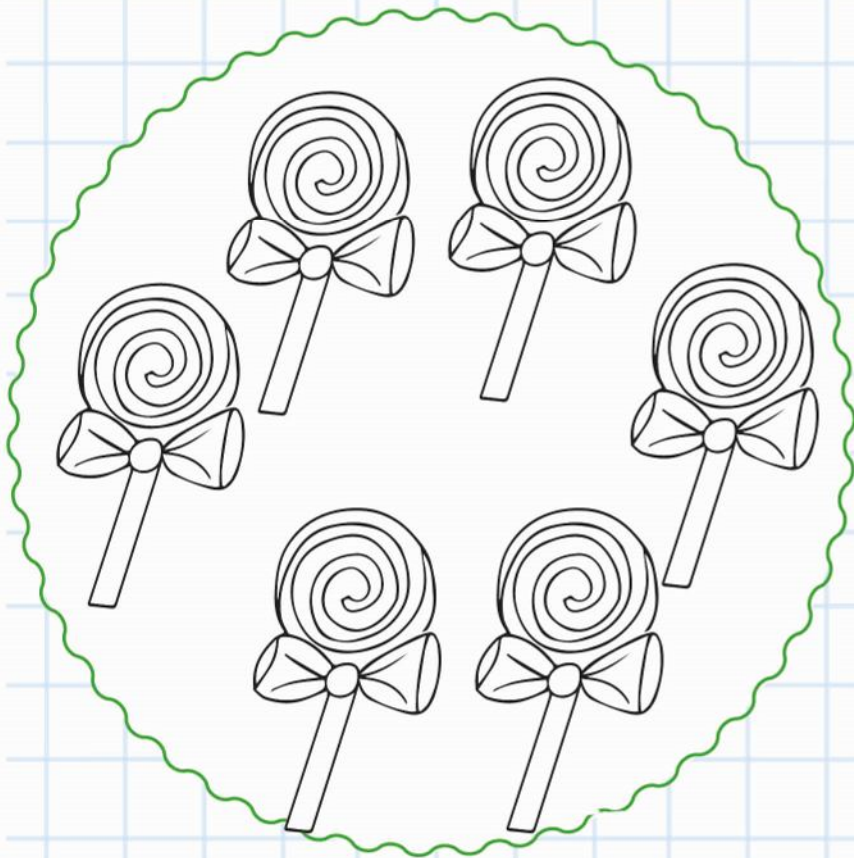





Mi nombre es: \_\_\_\_\_

\_\_\_\_\_

# Detrás - Delante

❖ Punza el borde del niño que está detrás de la silla.

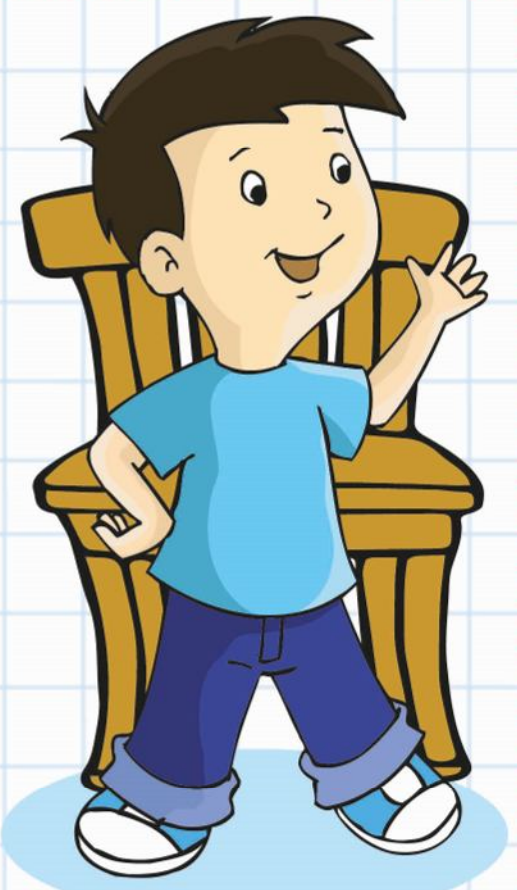
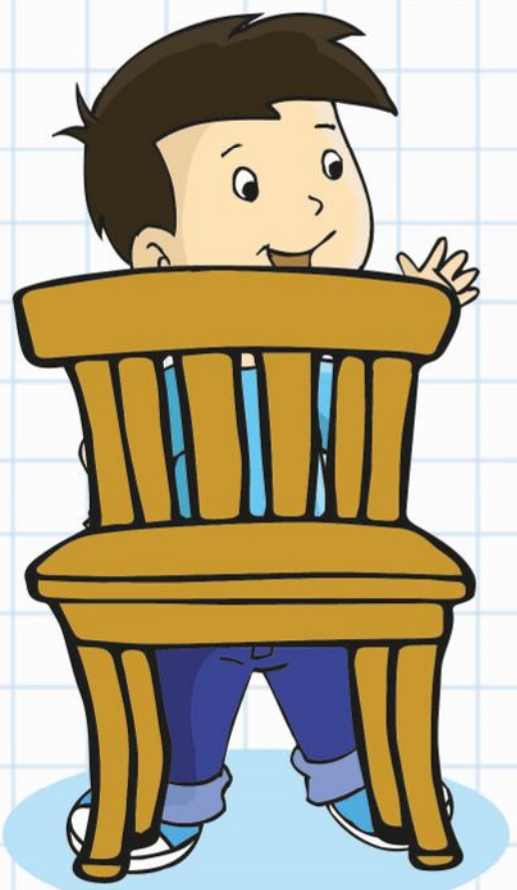



Mi nombre es: \_\_\_\_\_



❖ Marca (X) al niño que está delante de su padre.

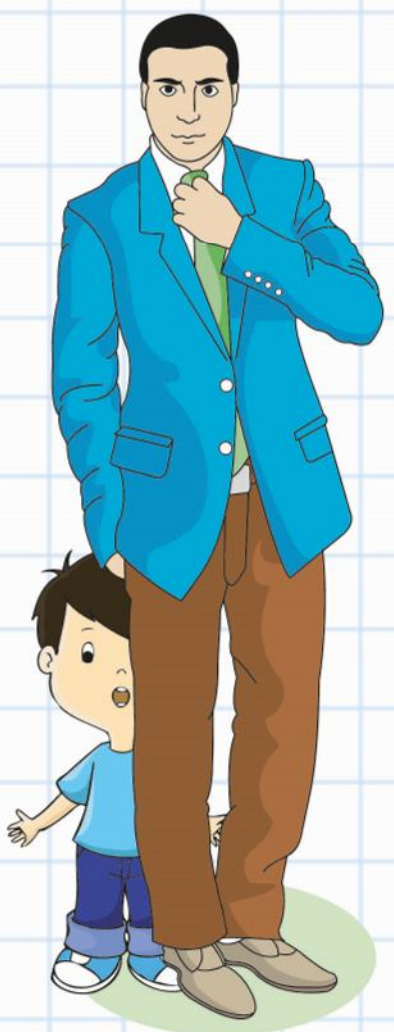



Mi nombre es: \_\_\_\_\_

--	--	--

❖ Rasga papel y pega en el elefante que está delante y colorea el elefante que está detrás de su mamá.

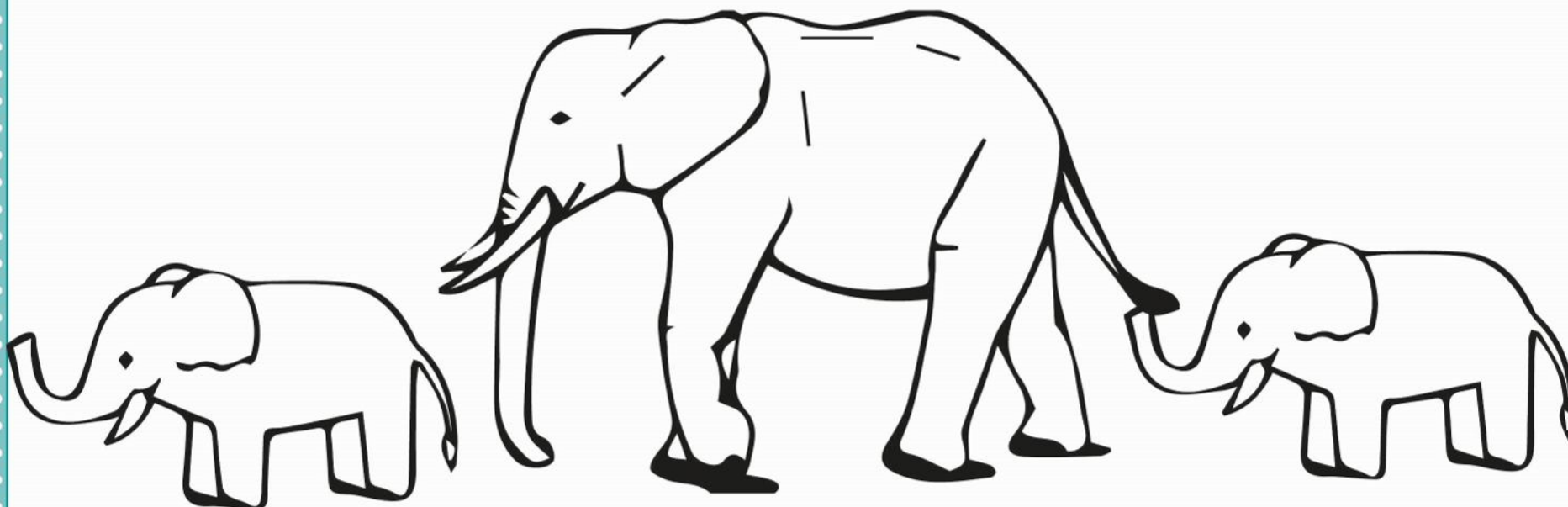



Mi nombre es: \_\_\_\_\_



# Número uno

Colorea el pollito y pega bolitas de papel en el N° 1.

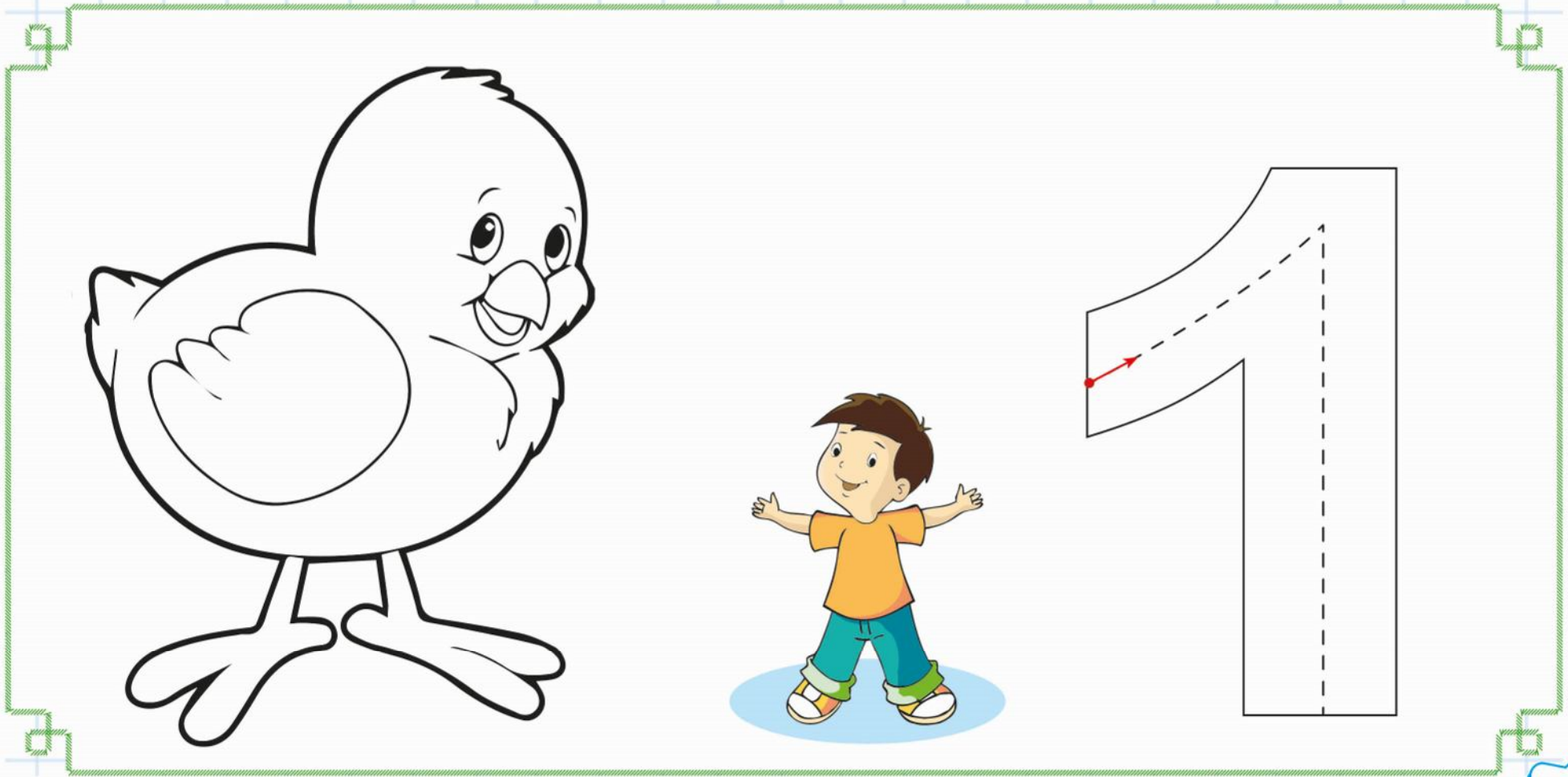



Mi nombre es: \_\_\_\_\_

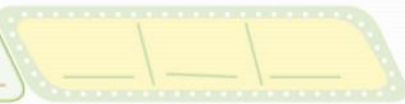

❖ Repasa el número 1 con plumón grueso de color.

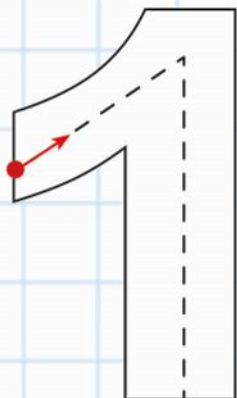
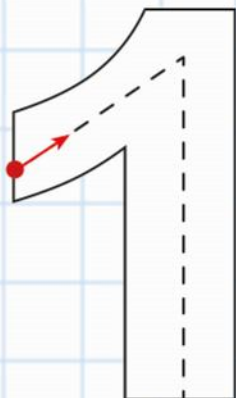
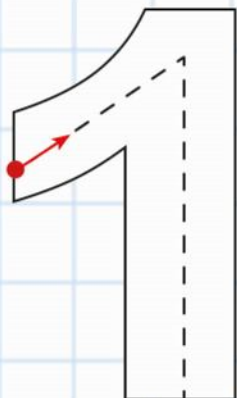
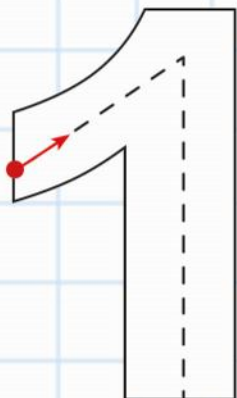
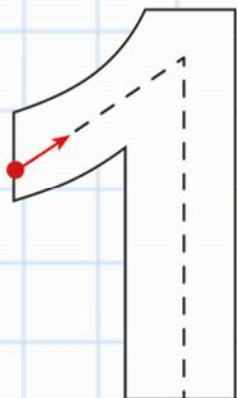
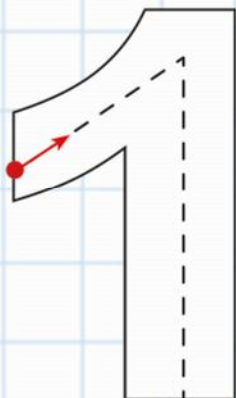
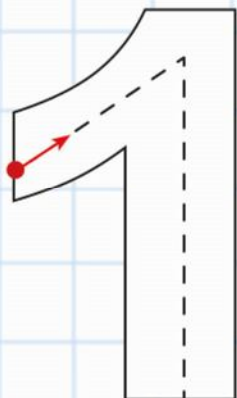
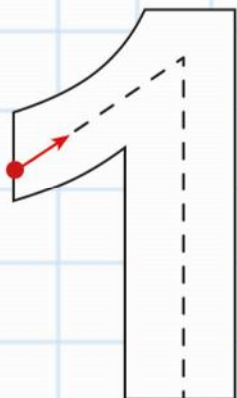





Mi nombre es: \_\_\_\_\_

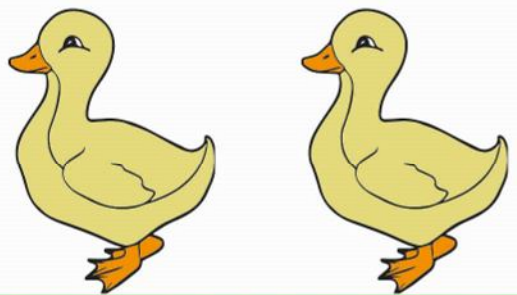

Marca con una (X) según el número indicado y colorea el número 1.

1 

1 

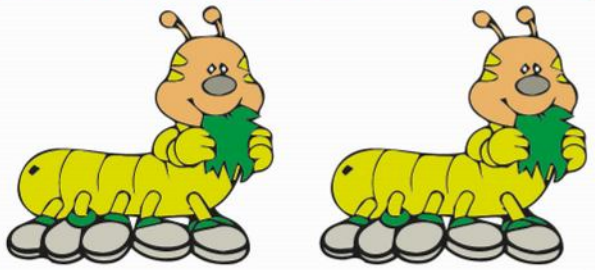
1 

1 



Mi nombre es: \_\_\_\_\_

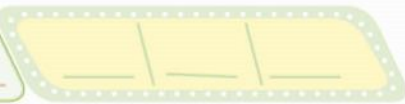

❖ Pinta los conjuntos que tengan un elemento.

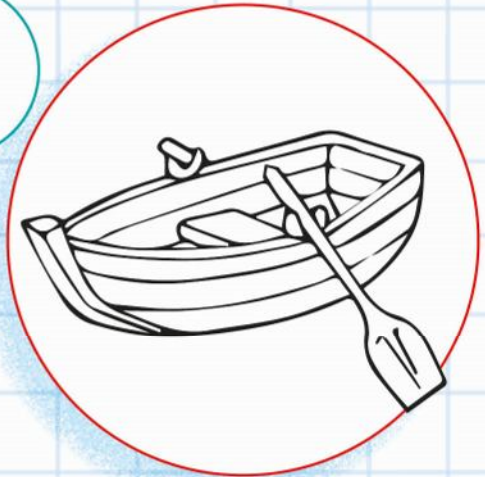
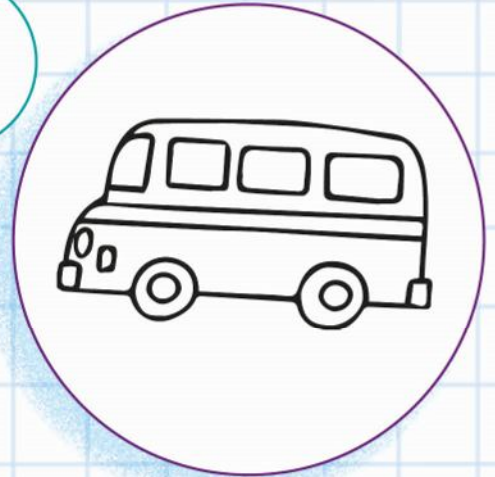
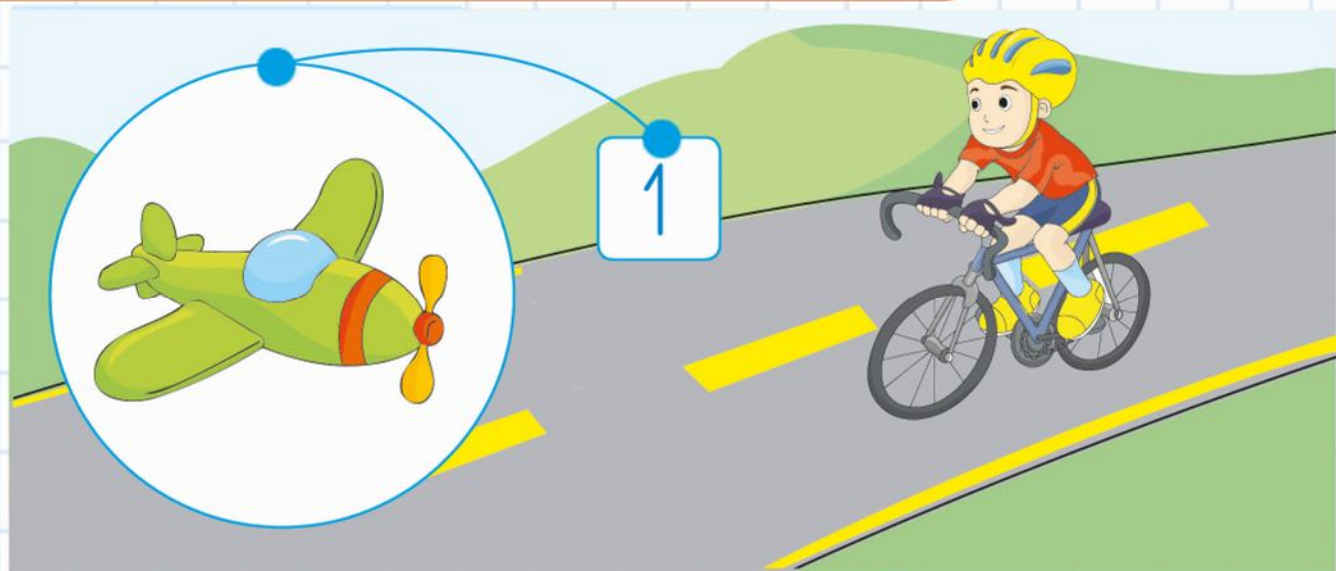



Mi nombre es: \_\_\_\_\_

\_\_\_\_\_



Une los números con la cantidad que corresponde.

2

1

2

1

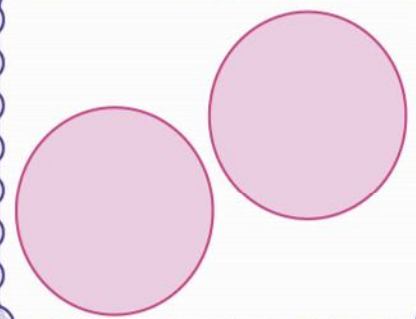
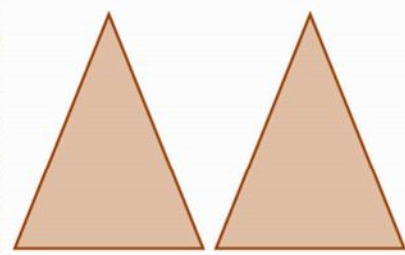



Mi nombre es: \_\_\_\_\_



1

Encierra en círculo dos galletas.

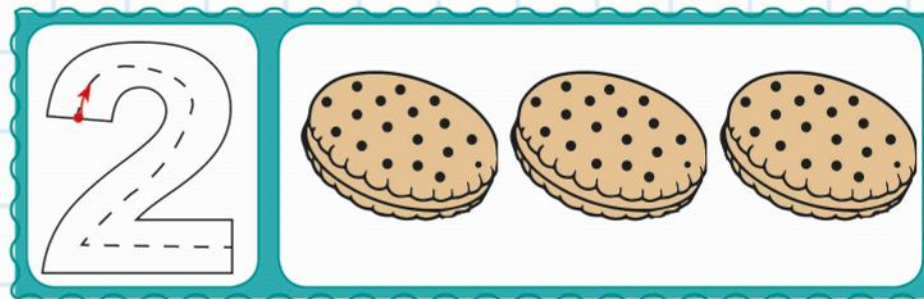

2

Colorea sólo dos chupetes.

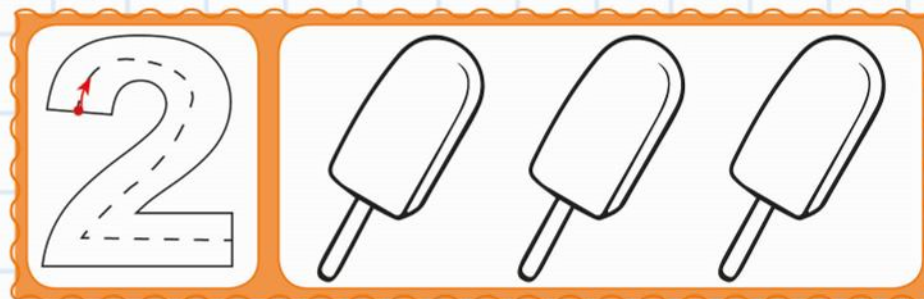

3

Marca con una (X) dos caballitos.

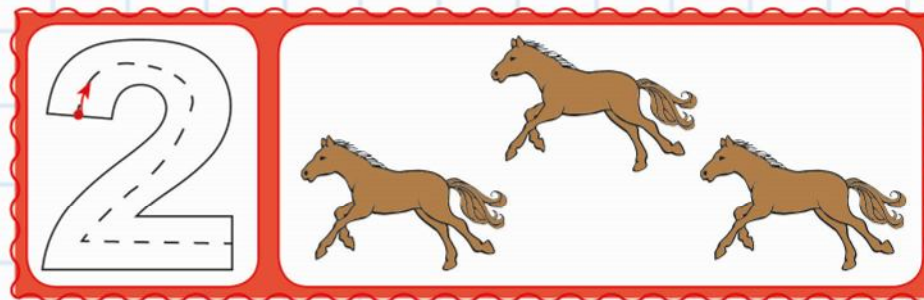



mi nombre es:

--	--	--

# El triángulo

◆ Haz huellitas con tempera, por los puntitos del triángulo.

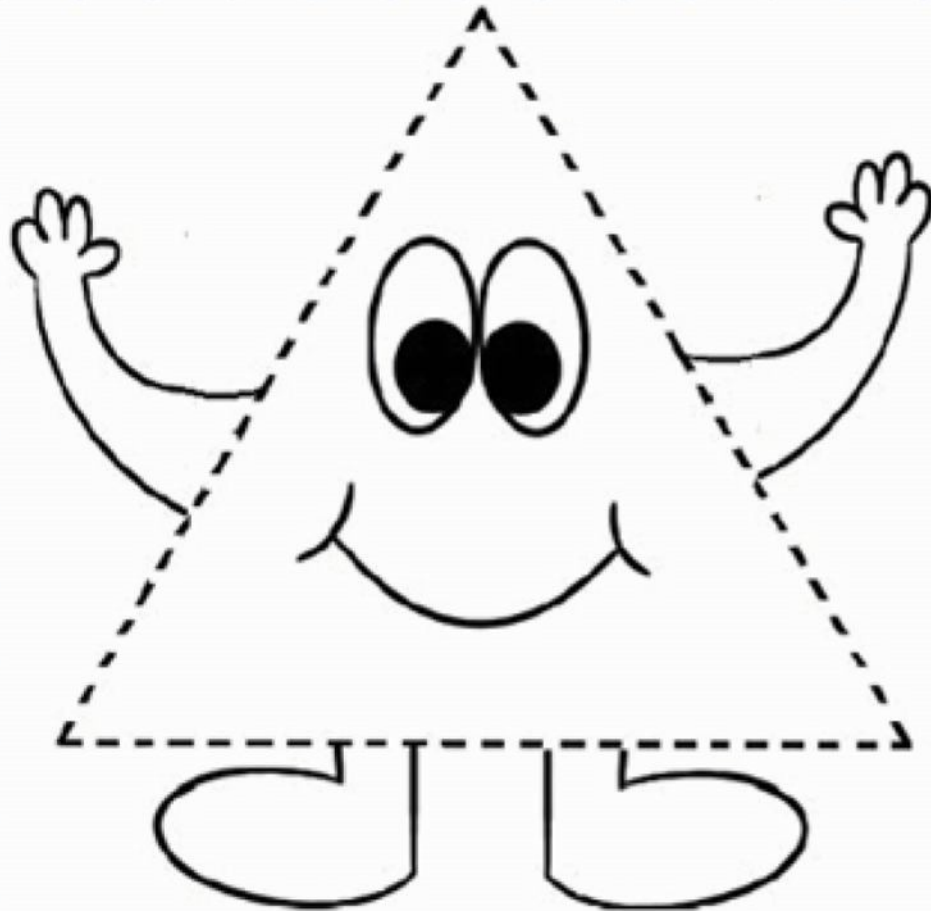

Soy el triángulo.  
Repasa mis tres lados  
y coloréame.



Mi nombre es: \_\_\_\_\_



◆ Repasa por los puntos del triángulo con plumón de colores y colorea de amarillo.

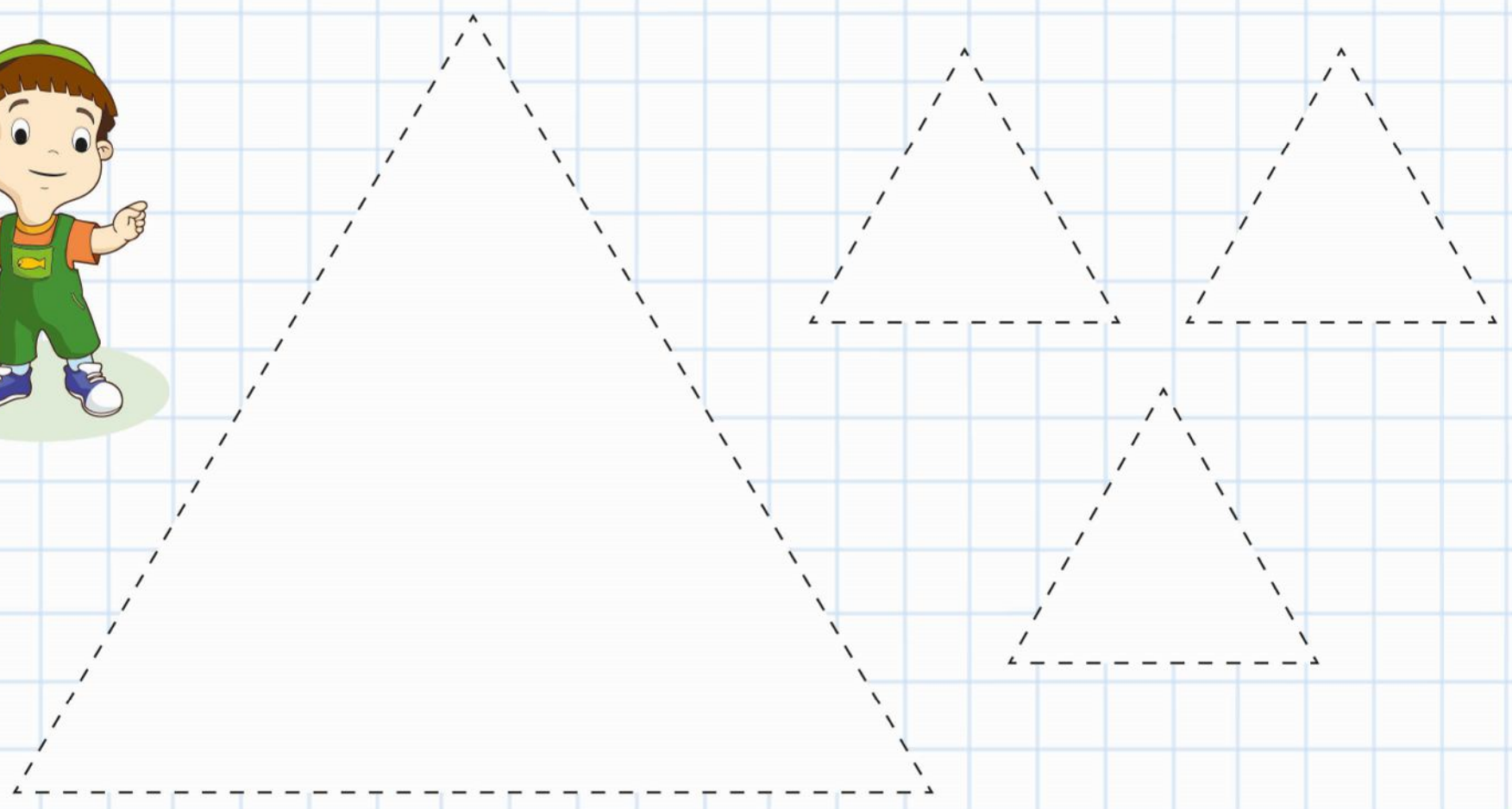



Mi nombre es: \_\_\_\_\_



# Largo - Corto

❖ Colorea el tren corto de rojo y el largo de azul.

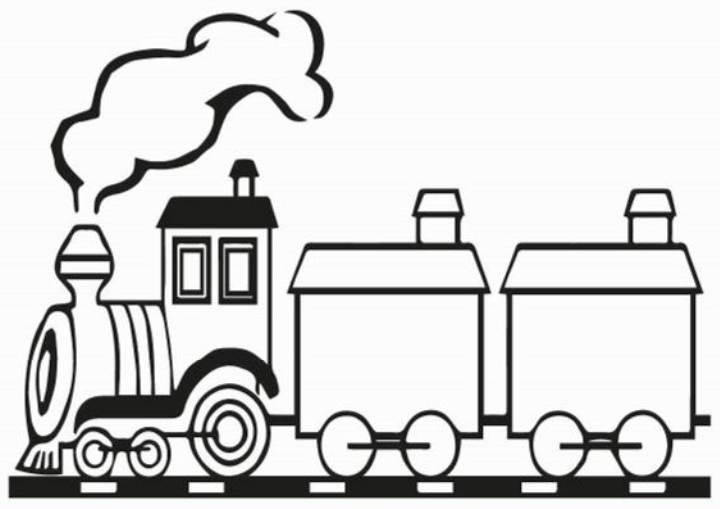
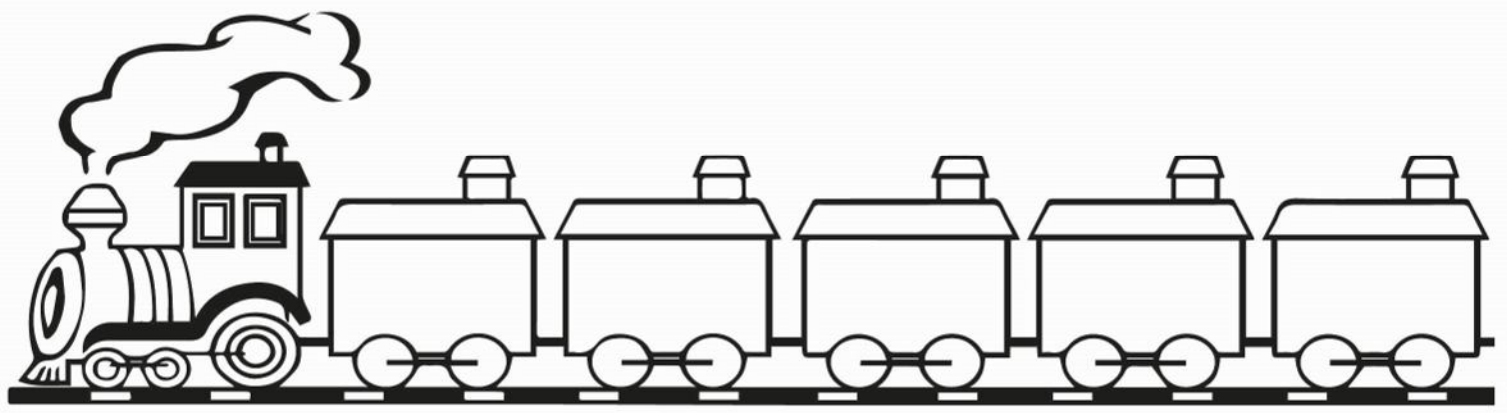



Mi nombre es: \_\_\_\_\_

\_\_\_\_\_



Con tu dedo índice colorea con t mpera el gusano largo.

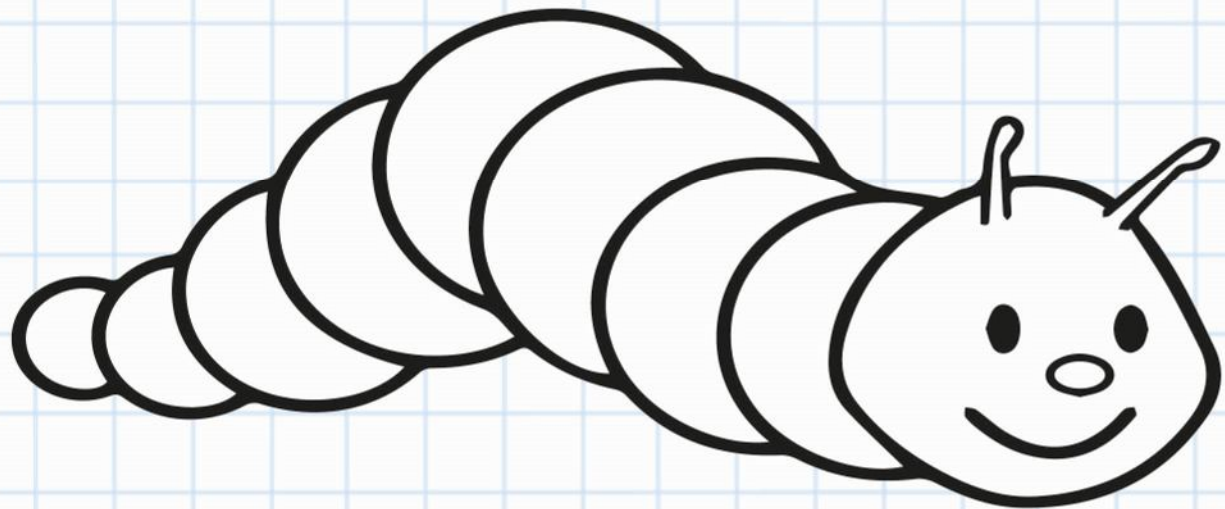
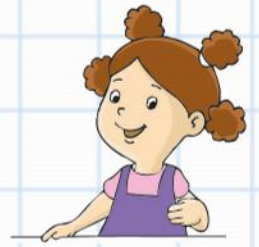



Mi nombre es: \_\_\_\_\_

\_\_\_\_\_



Rasga papel y pega en el lápiz corto.

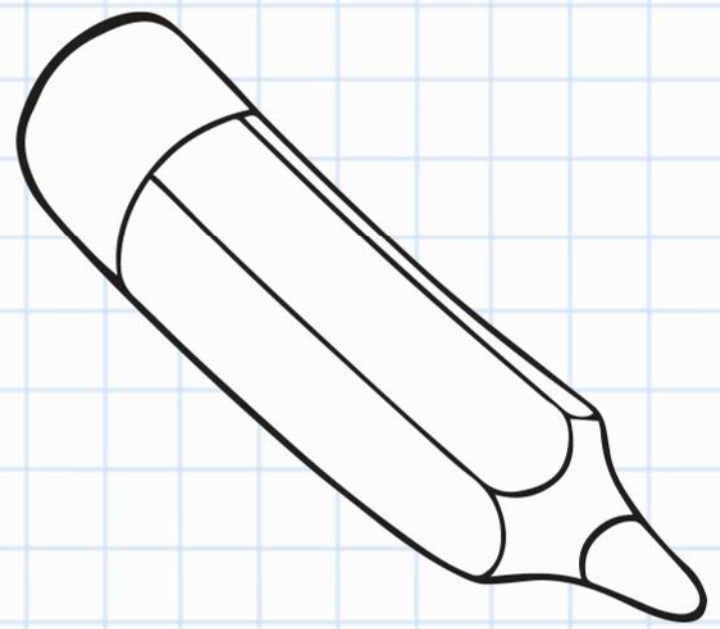
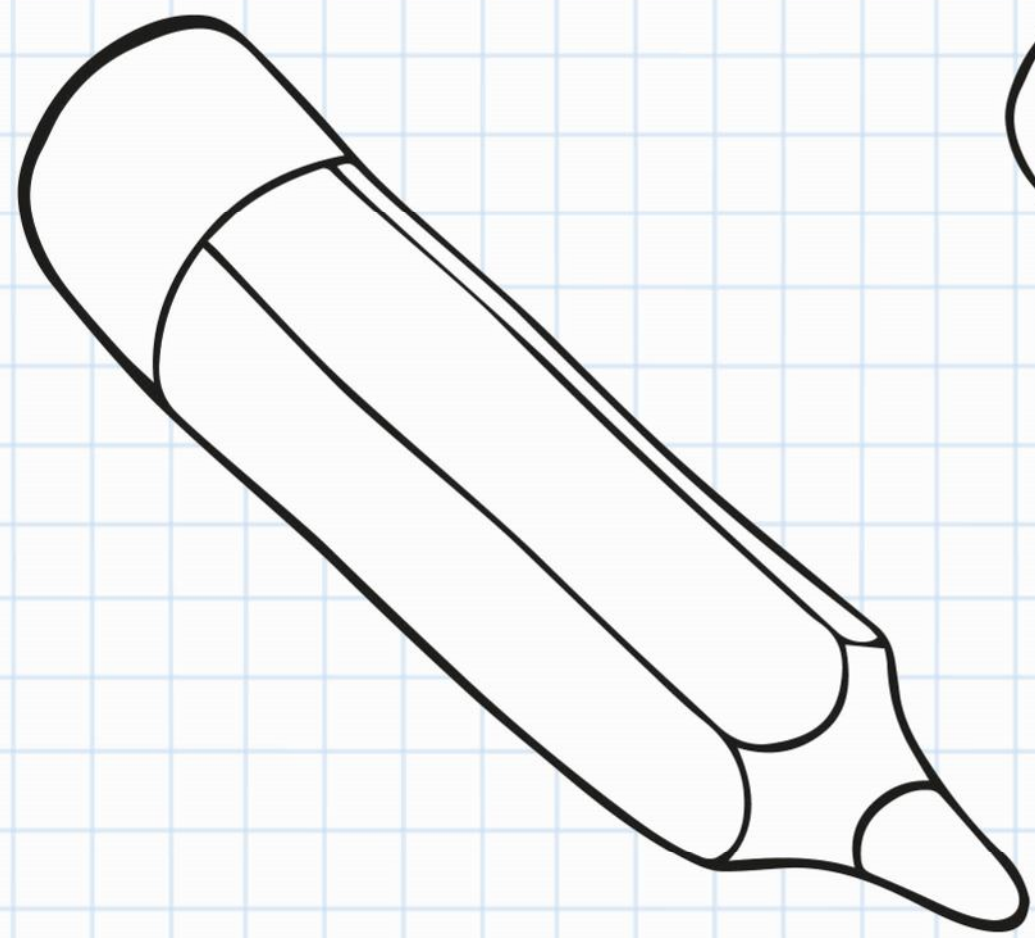



Mi nombre es: \_\_\_\_\_

❖ Delinea el N° 2 con plumón y colorea los monitos.

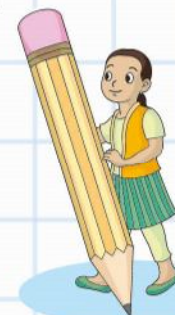
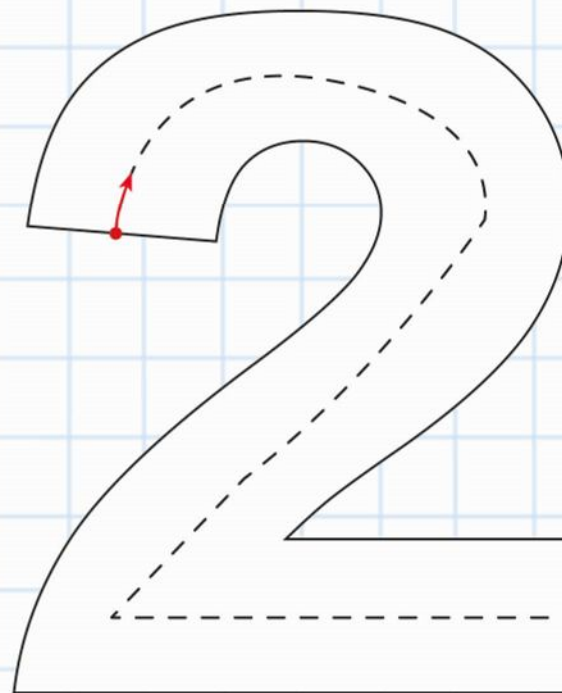
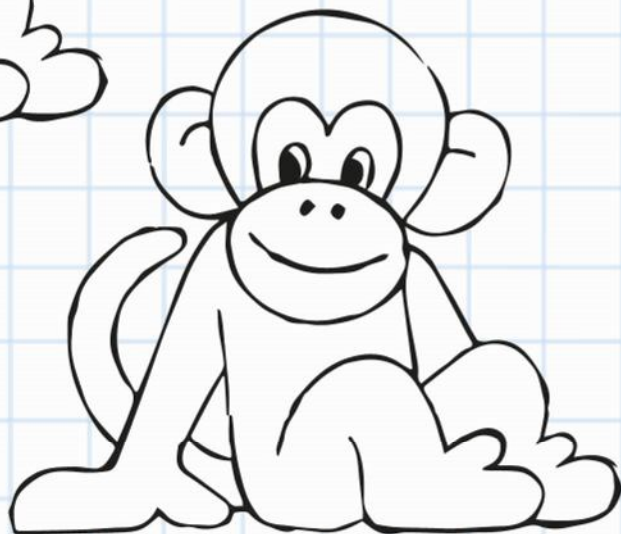
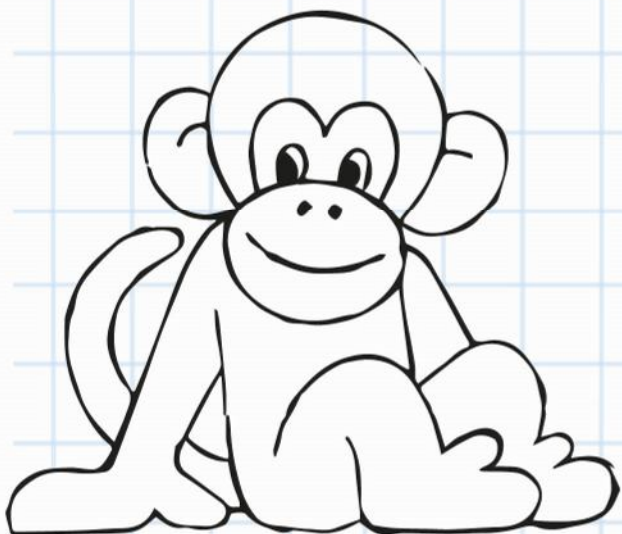



Mi nombre es: \_\_\_\_\_

\_\_\_\_\_



Pega lentejitas por las líneas del número 2.

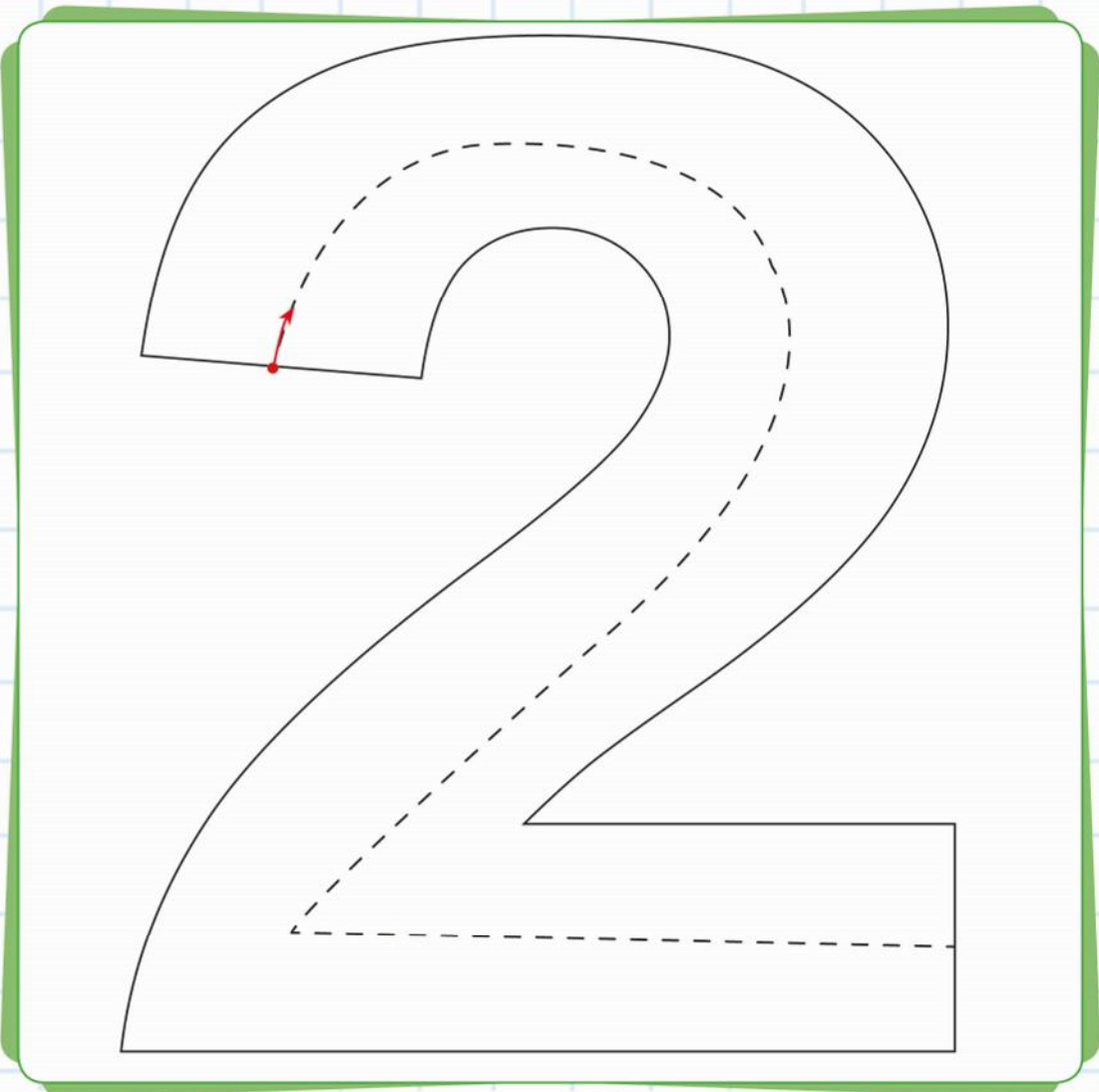
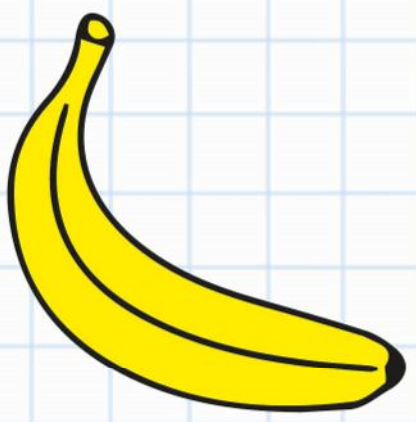
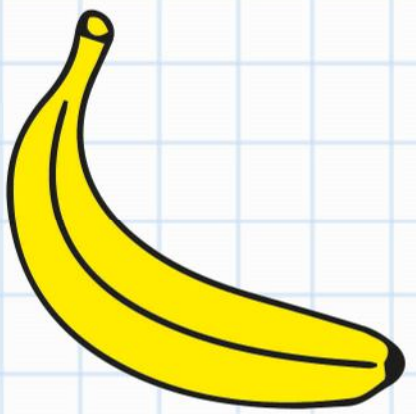





Mi nombre es: \_\_\_\_\_

\_\_\_\_\_

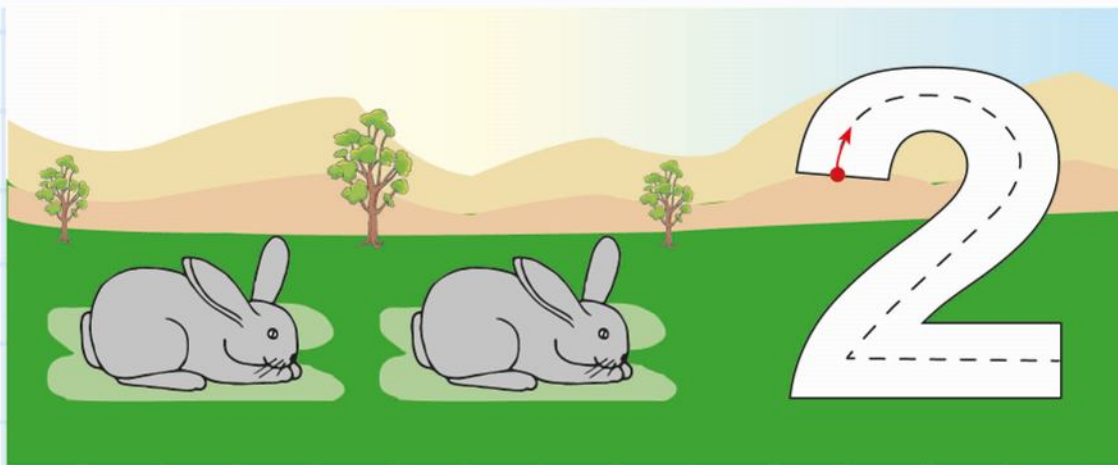

Repasa con plumón el número 2.

2 2 2 2 2 2 2 2

2 2 2 2 2 2 2 2

2 2 2 2 2 2 2 2



Mi nombre es: \_\_\_\_\_

\_\_\_\_\_

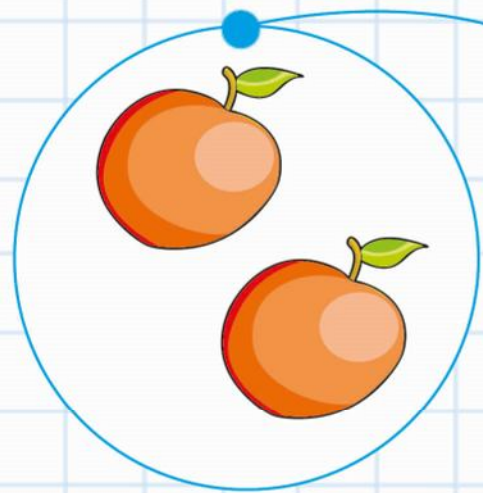

2



❖ Colorea los conjuntos que tengan dos elementos.

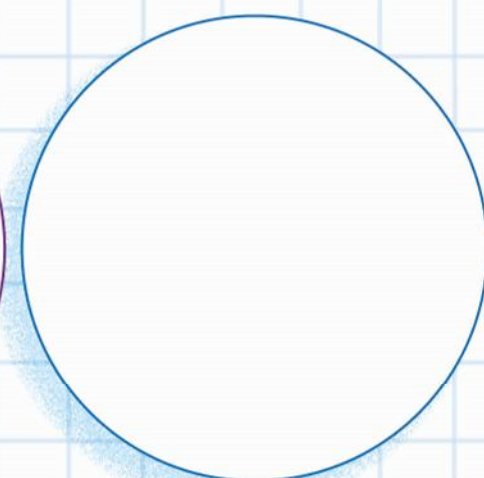
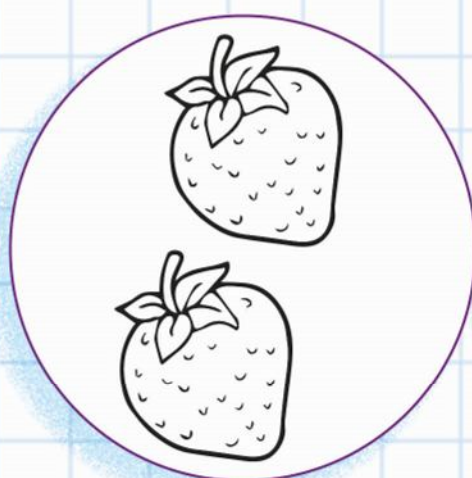
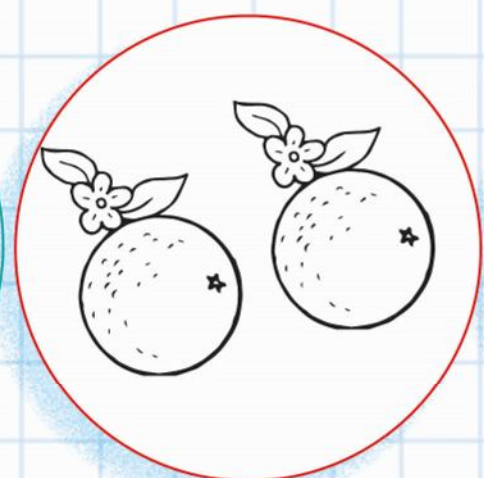
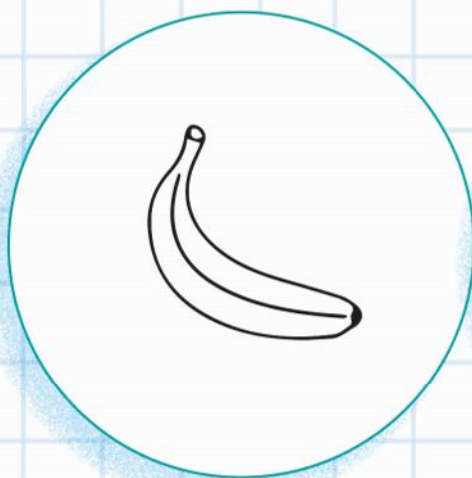

Mi nombre es: \_\_\_\_\_

## Actividad complementaria

### ¡Juego y aprendo!

#### Finalidad:

- \* Desarrollar la coordinación motora
- \* Desarrollar la percepción visual
- \* Reconocer colores
- \* Desarrollo de atención y concentración

#### Materiales:

- \* Plastilina
- \* Brochetas
- \* Paliglobos de colores





f Guía de Clases JB

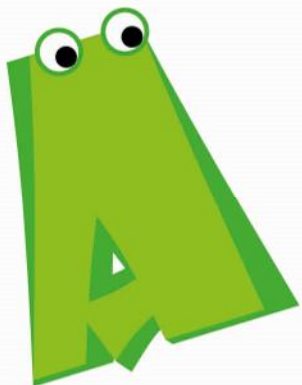

# Comunicación





Mi nombre es: \_\_\_\_\_

# Sonidos onomatopéyicos

❖ Con ayuda de tú profesora imita los sonidos de cada animalito.

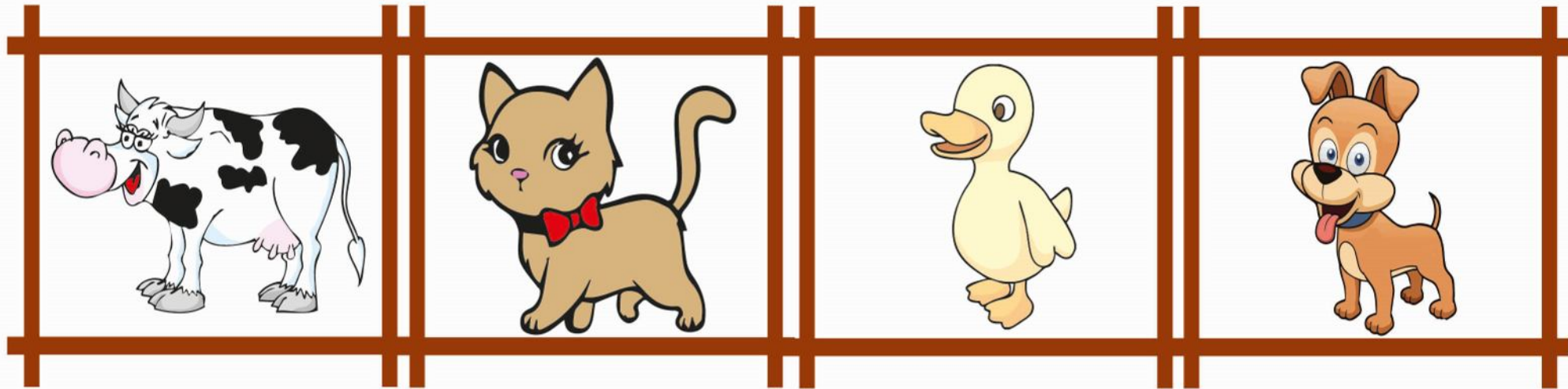

Muuu

Miau miau

Cua cua

Guau guau



Mi nombre es: \_\_\_\_\_



❖ Escucha atentamente y colorea las figuras que imita tu profesora.

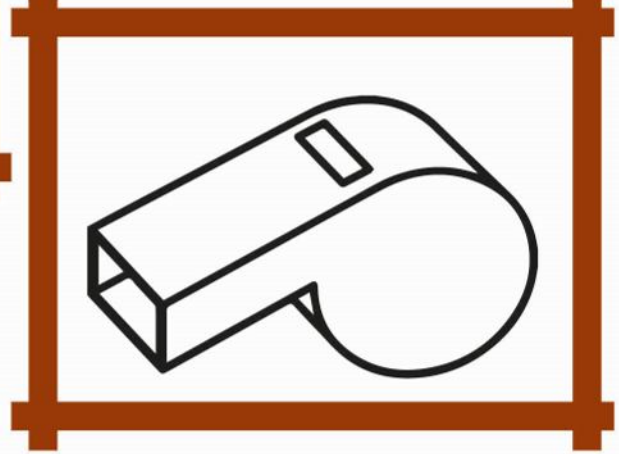
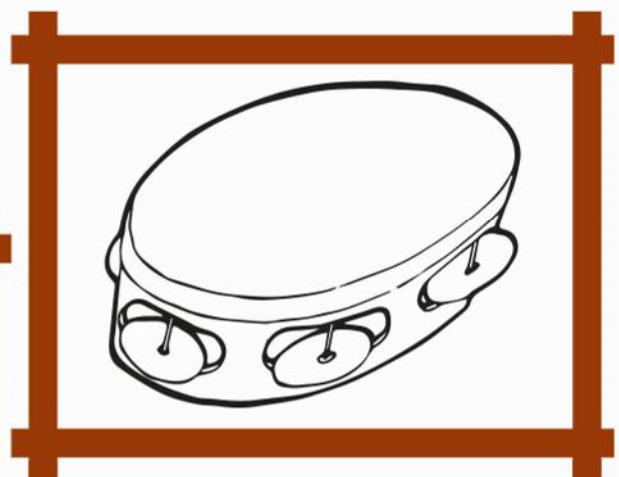
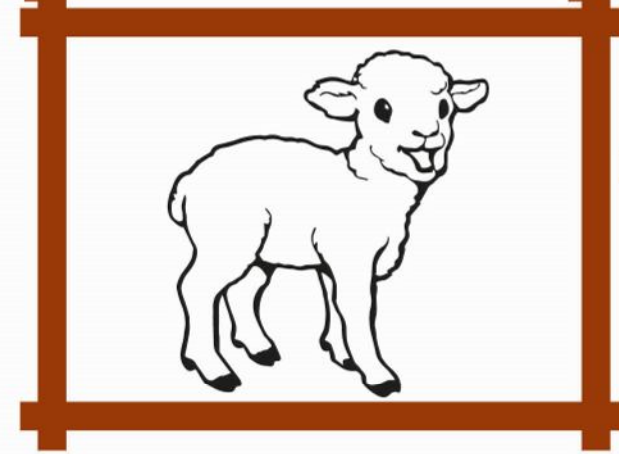
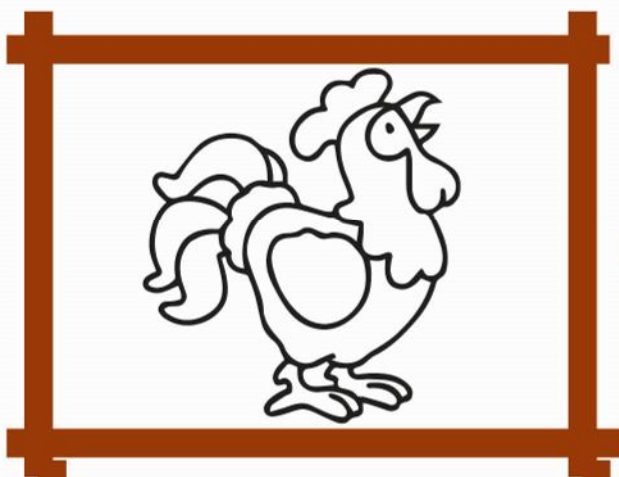



Mi nombre es: \_\_\_\_\_



# Figuras iguales

❖ Pinta con t mpera la imagen que es igual al modelo. Utiliza un hisopo.

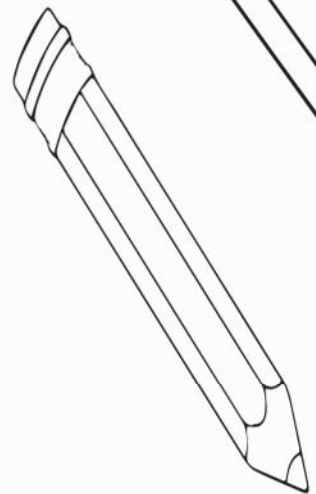
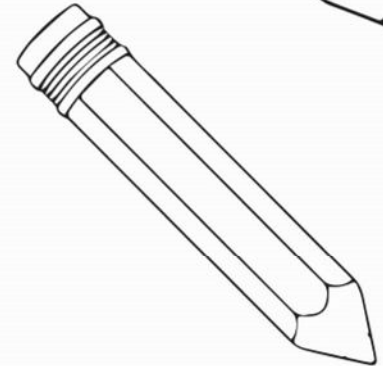
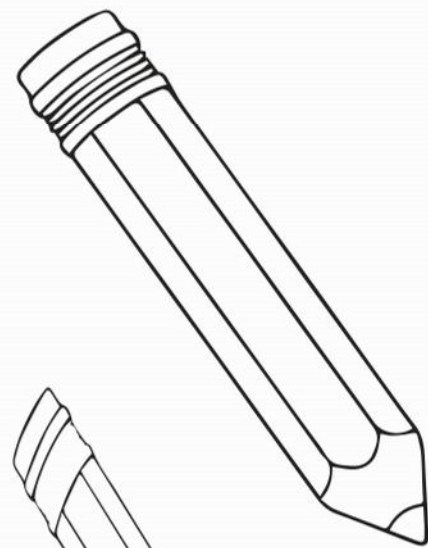
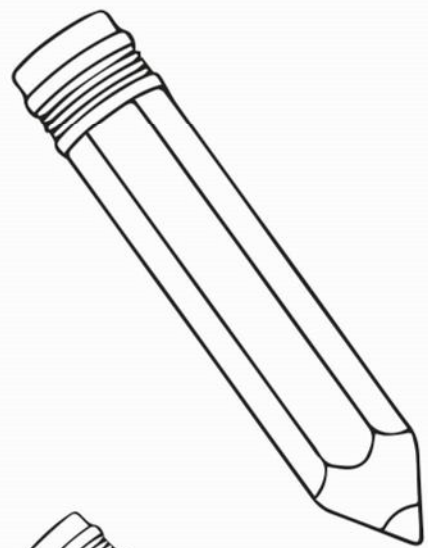
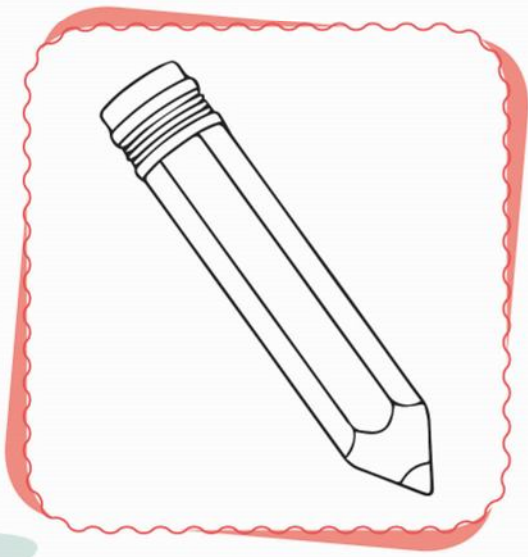



Mi nombre es: \_\_\_\_\_

\_\_\_\_\_

❖ Pinta con t mpera la imagen que es igual al modelo. Utiliza un hisopo.







Mi nombre es: \_\_\_\_\_



# Canción



Colorea el caracolito.

## Caracolito

Caracolito,  
 caracolito  
 quién te hizo tan  
 chiquito  
 si tu te asomas  
 hacia la arena  
 el agua te llevará  
 y el pobre  
 caracolito  
 solito se quedará.

Caracolote,  
 caracolote  
 quién te hizo tan  
 grandote  
 si tu te asomas  
 hacia la arena  
 el agua te llevará  
 y el pobre  
 caracolote  
 solote se quedará.

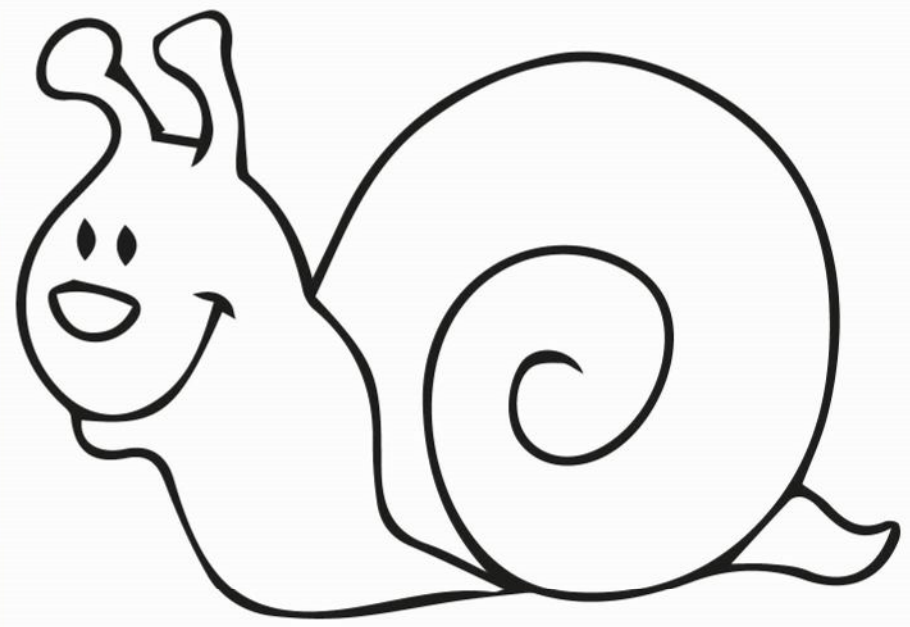



Mi nombre es:

\_\_\_\_\_

\_\_\_\_

# ¿Adivina quién soy?



Soy animal y vivo en el agua.



Soy un postre frío, dulce y sabroso.



Soy un astro y doy luz y calor.



Soy de cuero y calzo tus pies.





Mi nombre es: \_\_\_\_\_

--	--	--

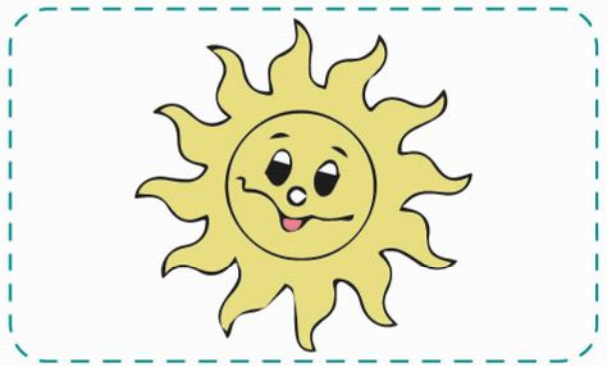
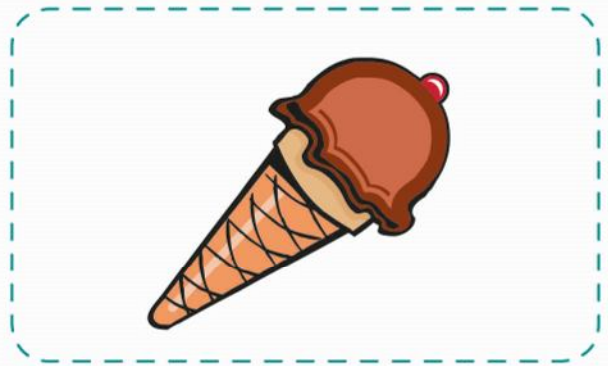

RECORTA

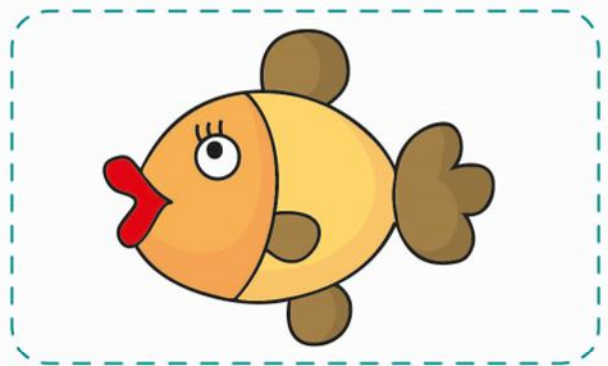



Mi nombre es: \_\_\_\_\_

# Rima

❖ Aprende y pinta la figura que corresponda a la rima.

**El payaso**  
 Cuando el payaso  
 está feliz  
 se le cae la nariz.





Mi nombre es: \_\_\_\_\_

--	--	--

❖ Corta y pega donde corresponde de la siguiente página..

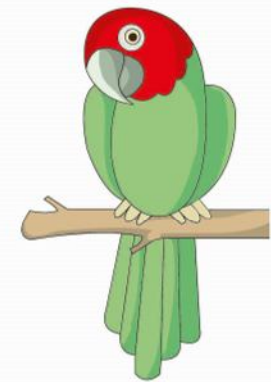



Mi nombre es: \_\_\_\_\_

\_\_\_\_\_

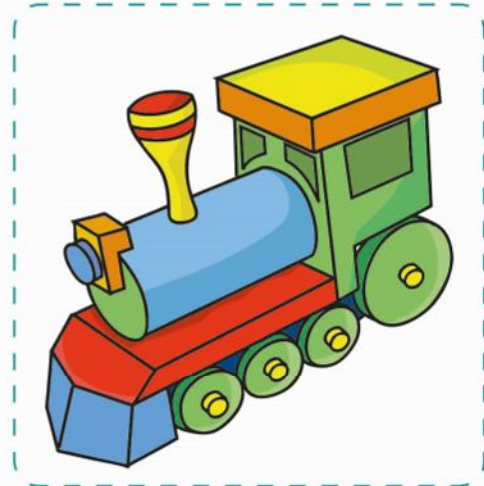
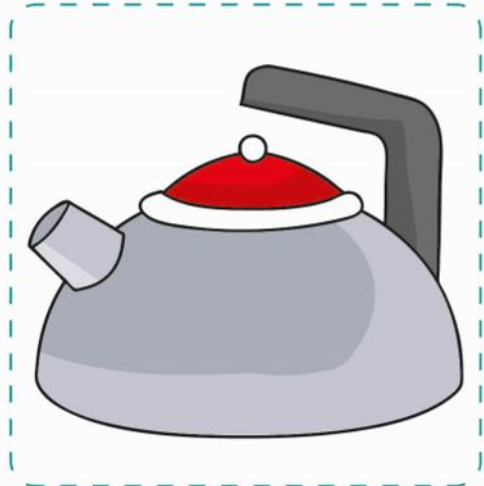
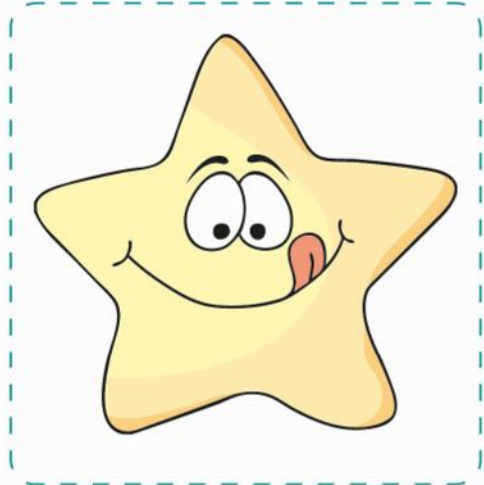



Mi nombre es: \_\_\_\_\_

\_\_\_\_\_

❖ Une las figuras con sus sombras iguales.

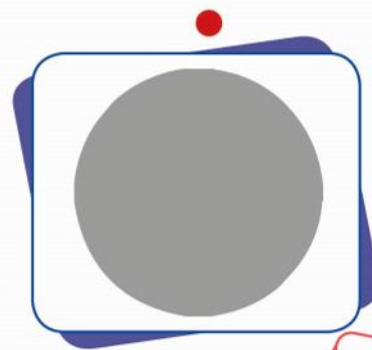
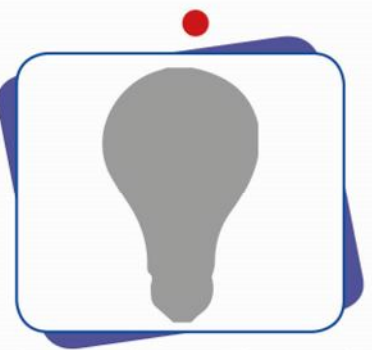
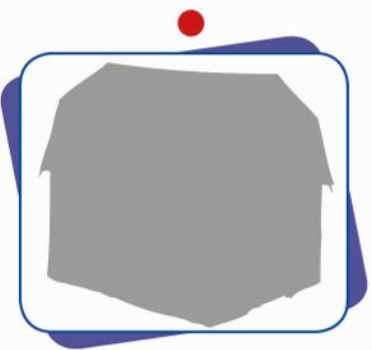



Mi nombre es: \_\_\_\_\_

\_\_\_\_\_

❖ Une las figuras con sus sombras iguales.

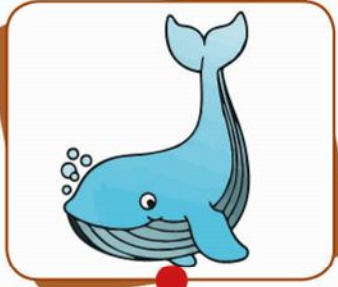
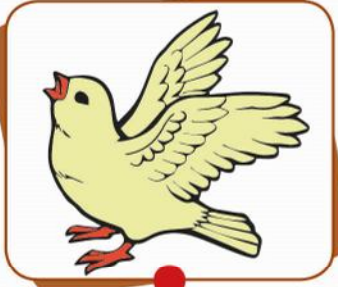





Mi nombre es: \_\_\_\_\_



# Percepción Visual

◆ Colorea, corta, arma y pega los animales en otra hoja.

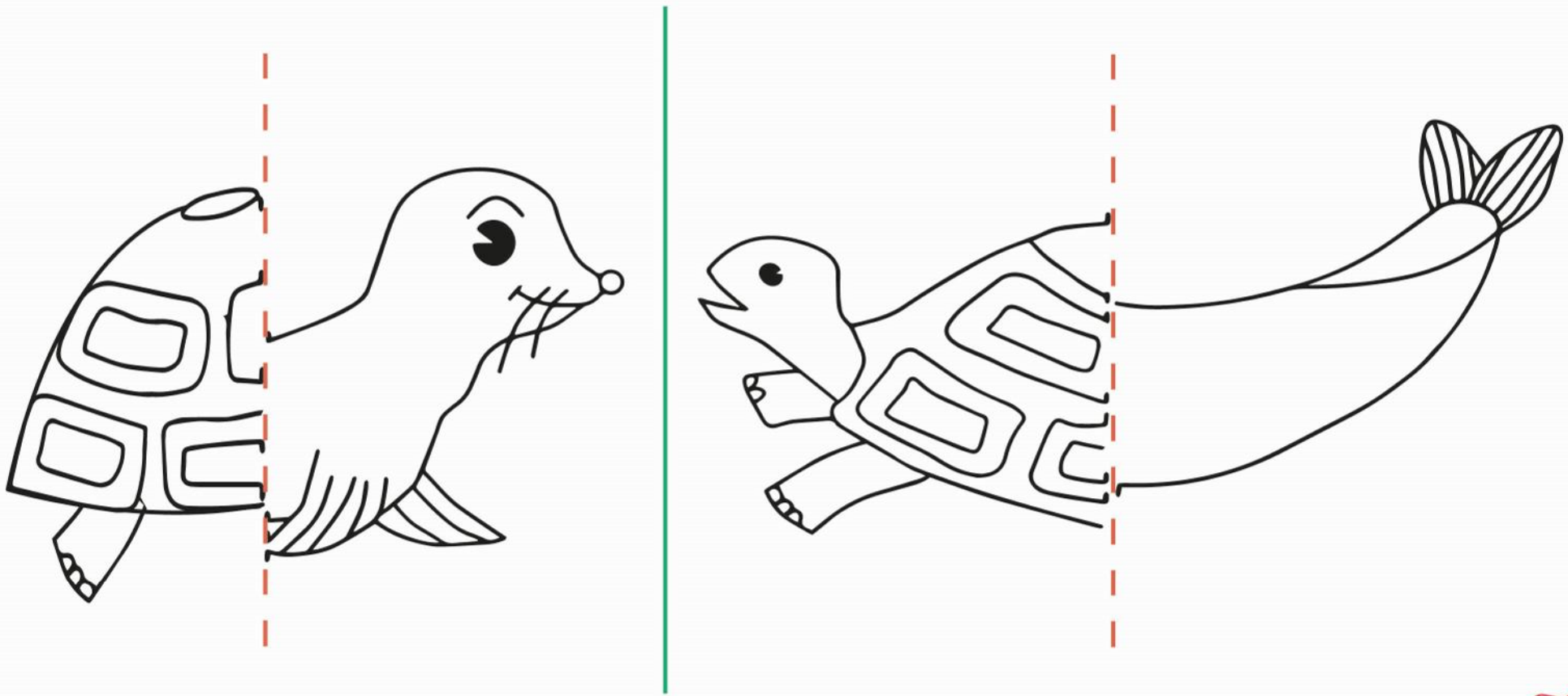



Mi nombre es: \_\_\_\_\_



# Vocal

❖ Traza con plumón grueso por las líneas punteadas de la vocal y pinta la imagen.

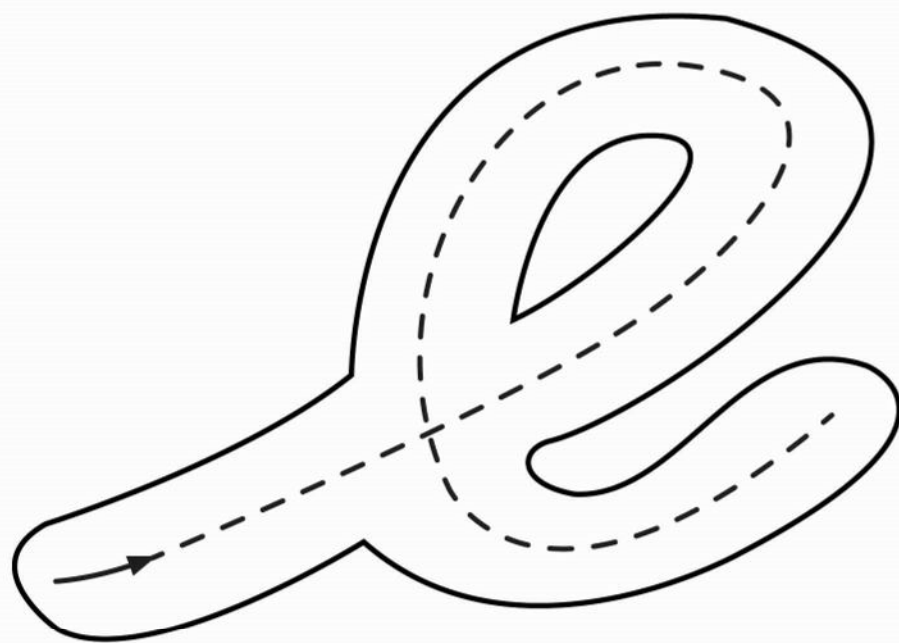



Mi nombre es: \_\_\_\_\_



❖ Pega plastilina en la vocal *e*.

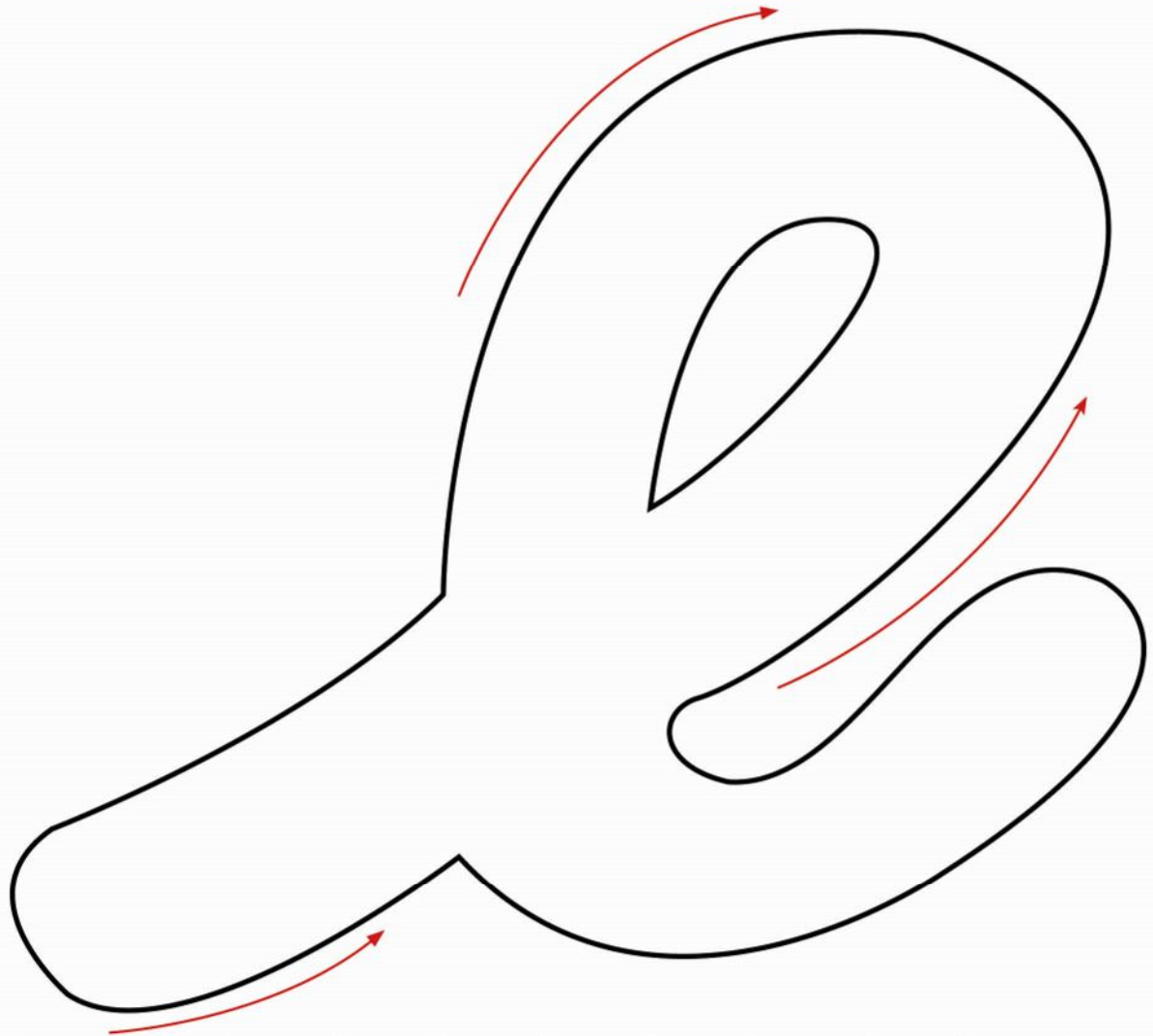



Mi nombre es: \_\_\_\_\_

--	--	--

❖ Embolilla crepé sobre la vocal *e*.

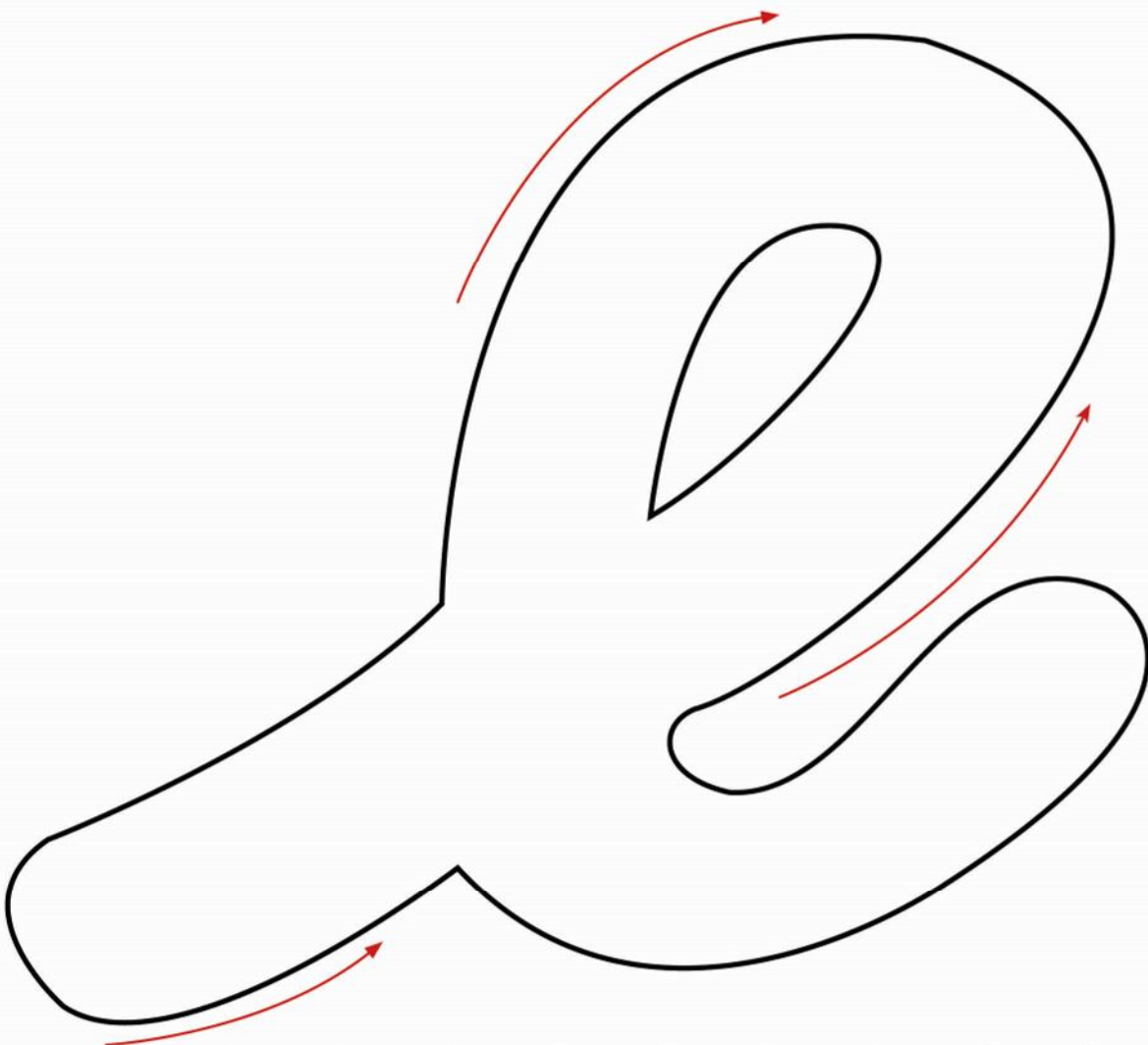



Mi nombre es: \_\_\_\_\_



❖ Pinta con tempera dentro de la vocal *e*.

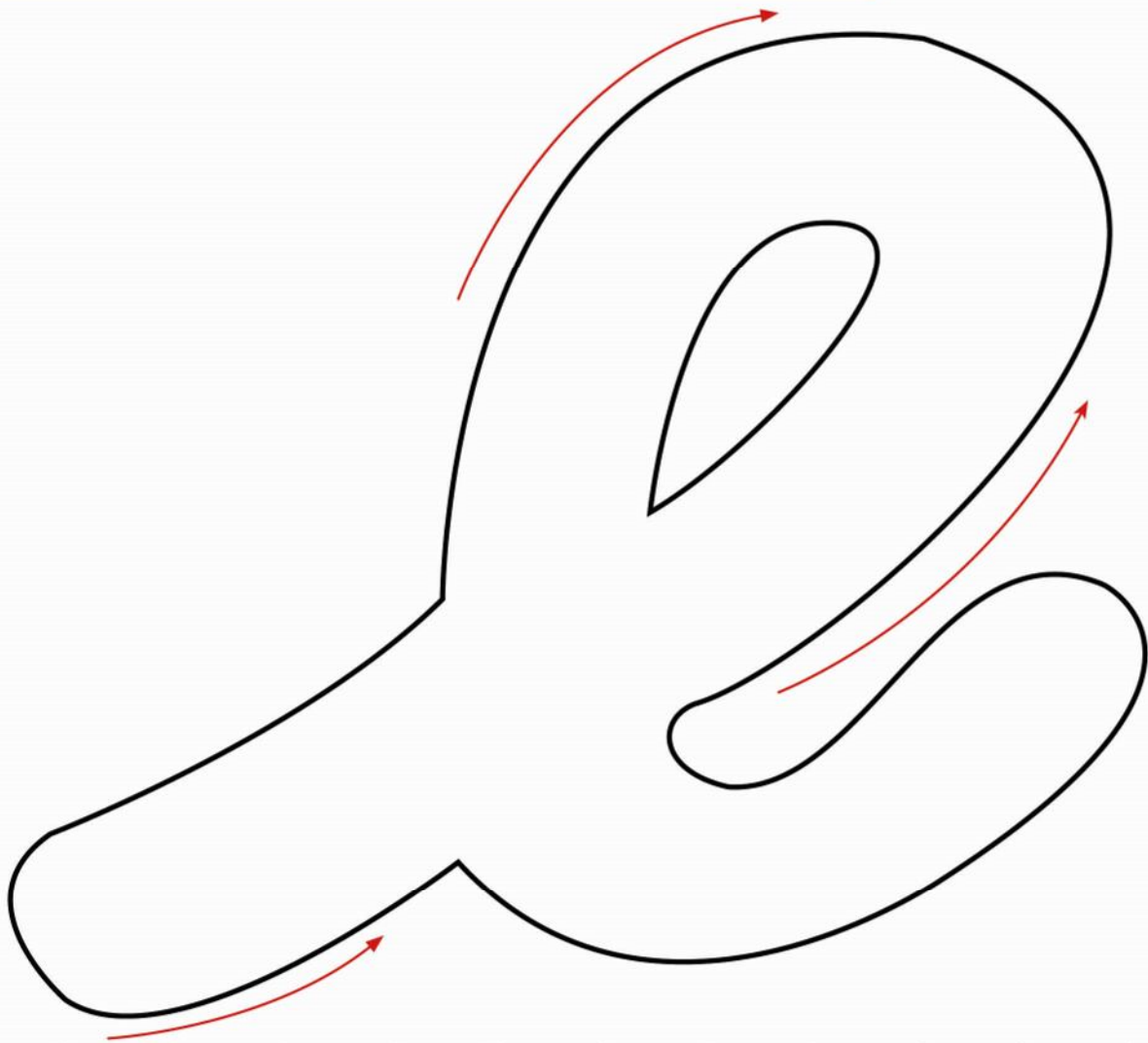



Mi nombre es: \_\_\_\_\_

--	--	--

❖ Pega bolitas de papel crepe y forma la vocal "e".

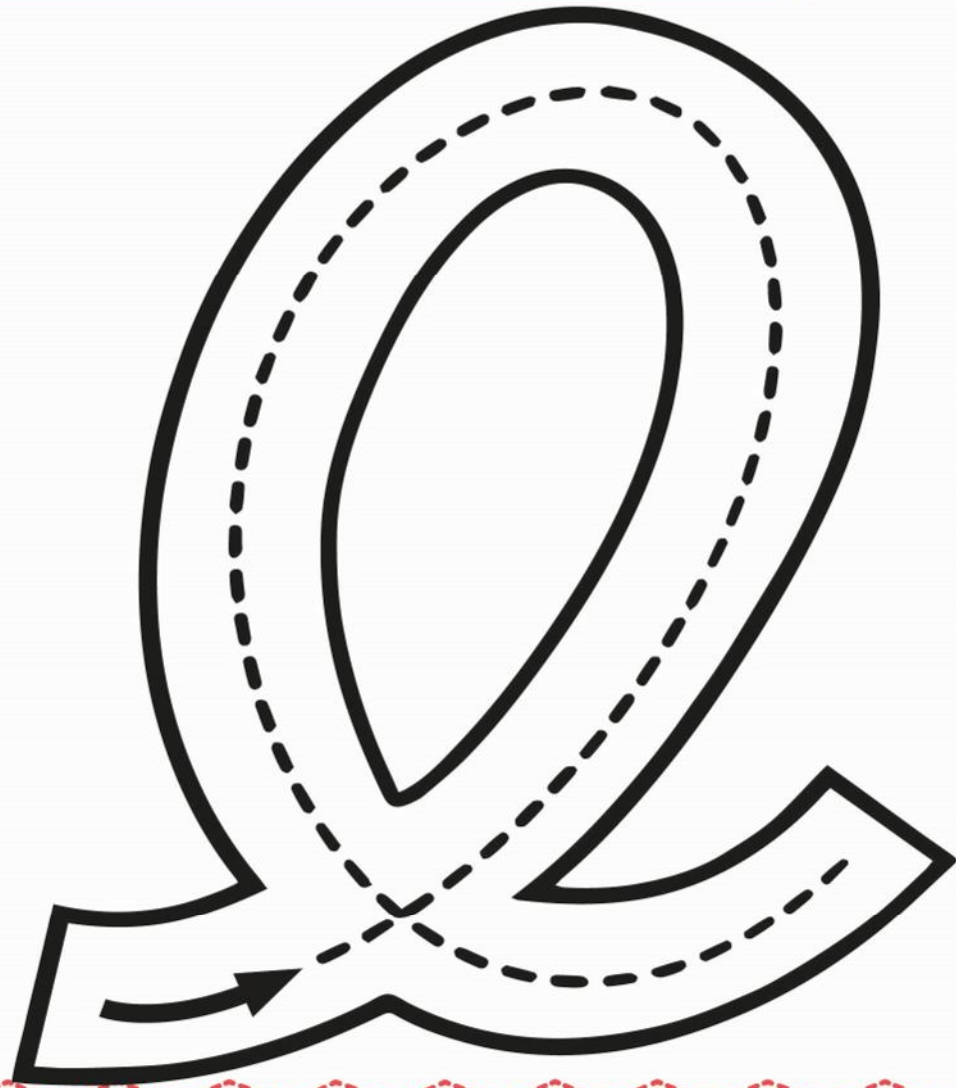



Mi nombre es: \_\_\_\_\_

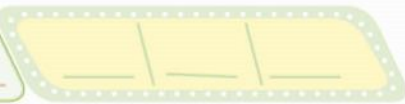

❖ Punza los puntitos, desglosa y pega papel de color por detrás de la hoja para formar la vocal "e".

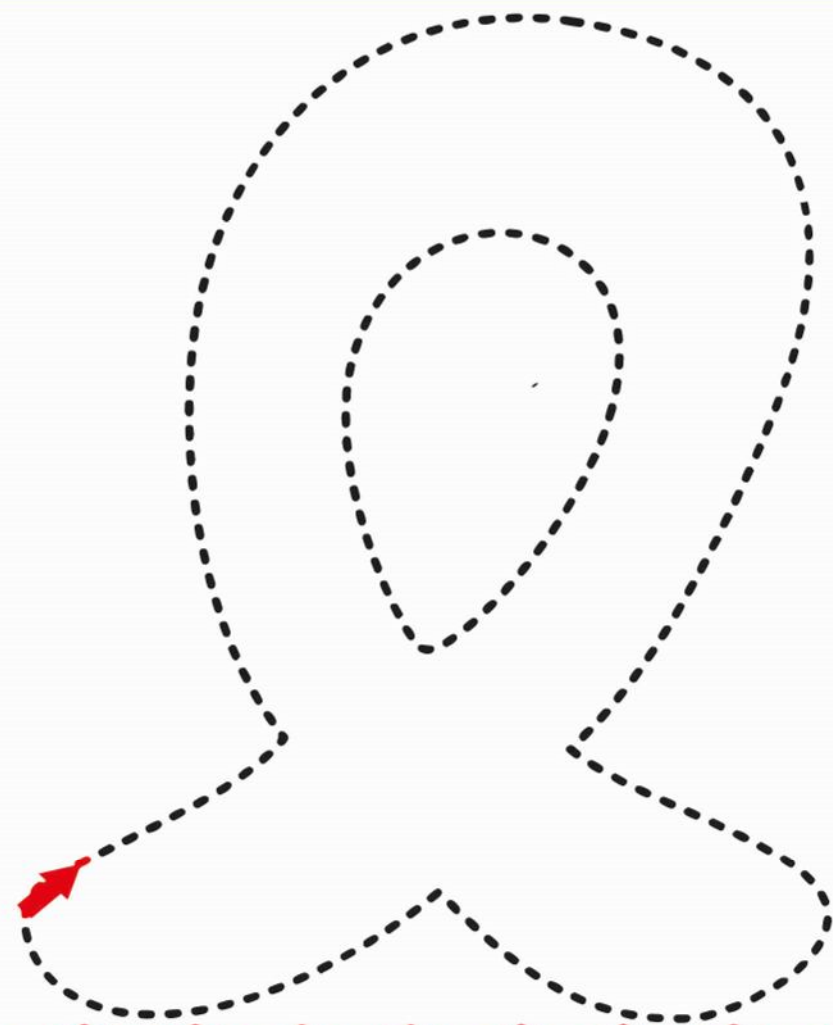



Mi nombre es: \_\_\_\_\_



❖ Pinta sólo a los objetos que empiecen con la "e":

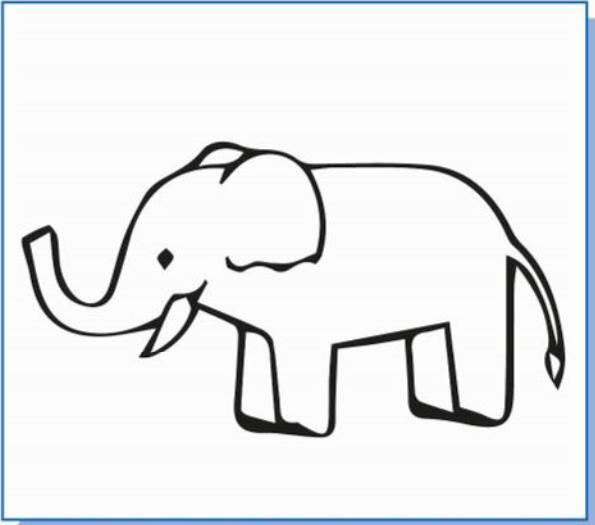
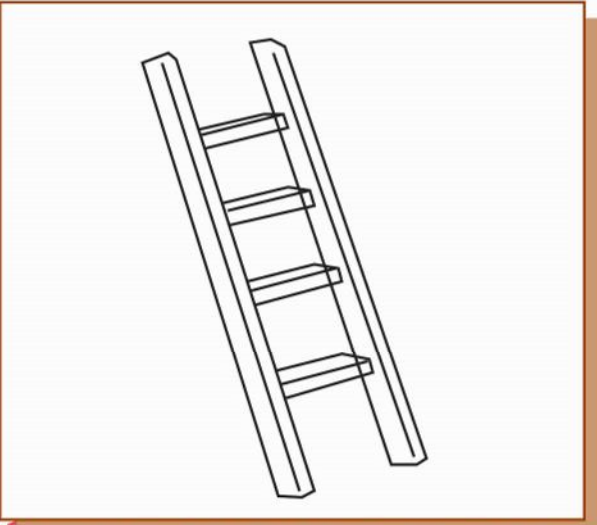
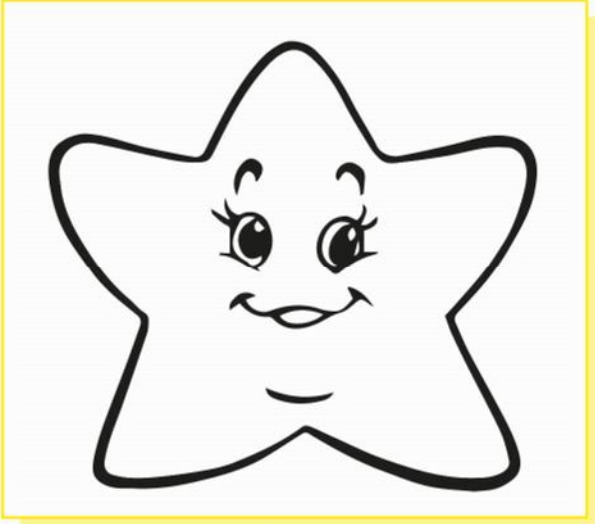
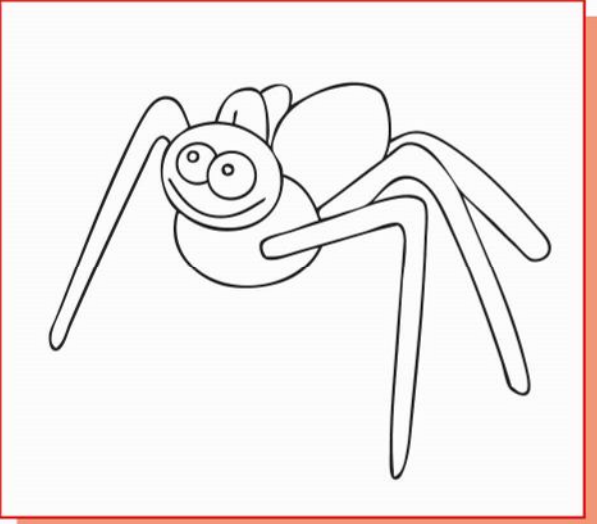





Mi nombre es: \_\_\_\_\_



❖ Punza cada uno de los puntitos, desglosa y pega por detrás papel lustre.

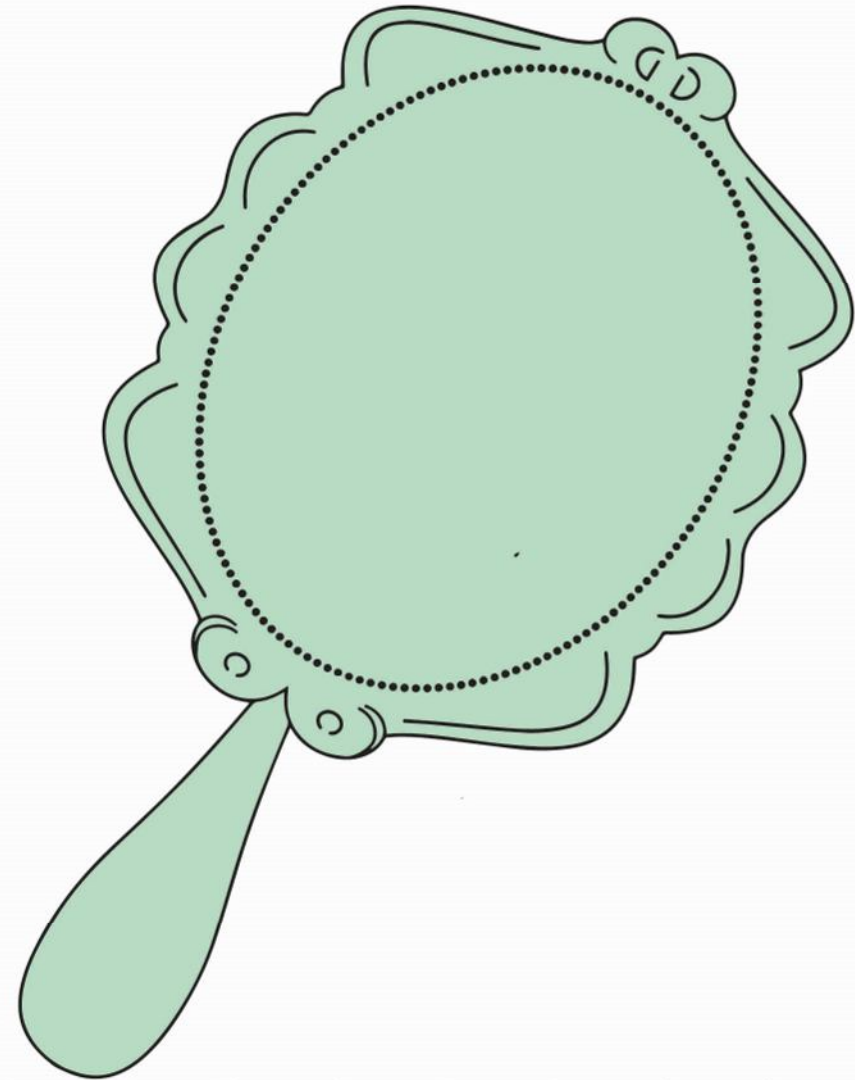



Mi nombre es: \_\_\_\_\_



❖ Rasga papel lustre amarillo y pégalo en la estrella grande.

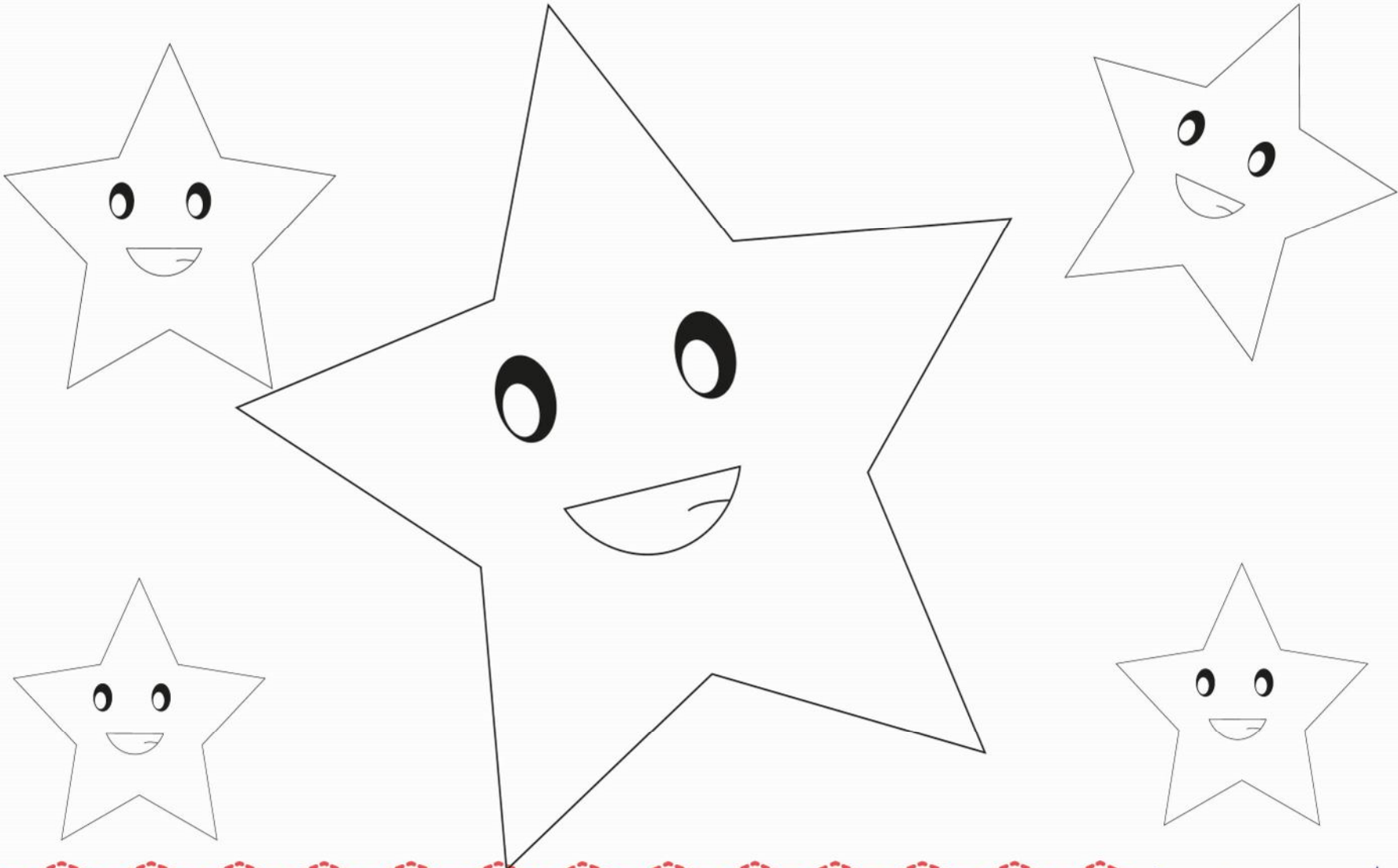



Mi nombre es: \_\_\_\_\_



◆ Punzar.

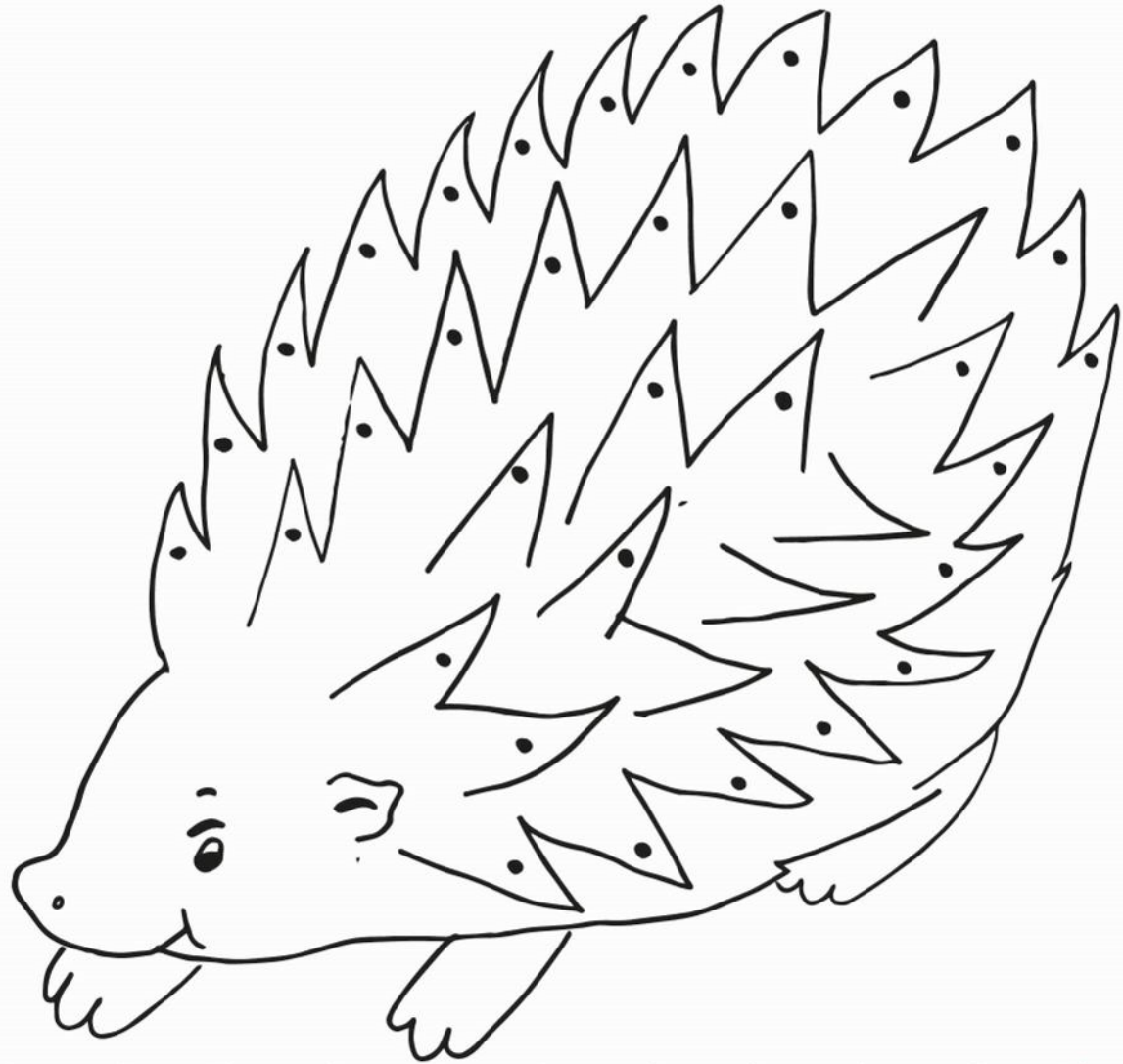



Mi nombre es: \_\_\_\_\_

Three empty rectangular boxes for writing.

❖ Encierra las vocales "e" que encuentres:

A large rectangular area with a dashed blue border and a light green background, containing the following cursive letters:

Row 1: i e a

Row 2: a i e o

Row 3: e e i



Mi nombre es: \_\_\_\_\_

# Relaciones analógicas

❖ Colorea las imágenes y relaciona las columnas con una línea según su complemento.





Mi nombre es: \_\_\_\_\_

\_\_\_\_\_

❖ Pinta las imágenes y relaciona las columnas con una línea según su complemento.

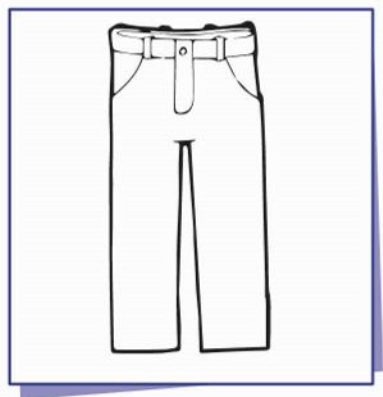



Mi nombre es: \_\_\_\_\_

--	--	--

# Poesía

❖ Aprende la poesía. Luego pinta las imágenes.

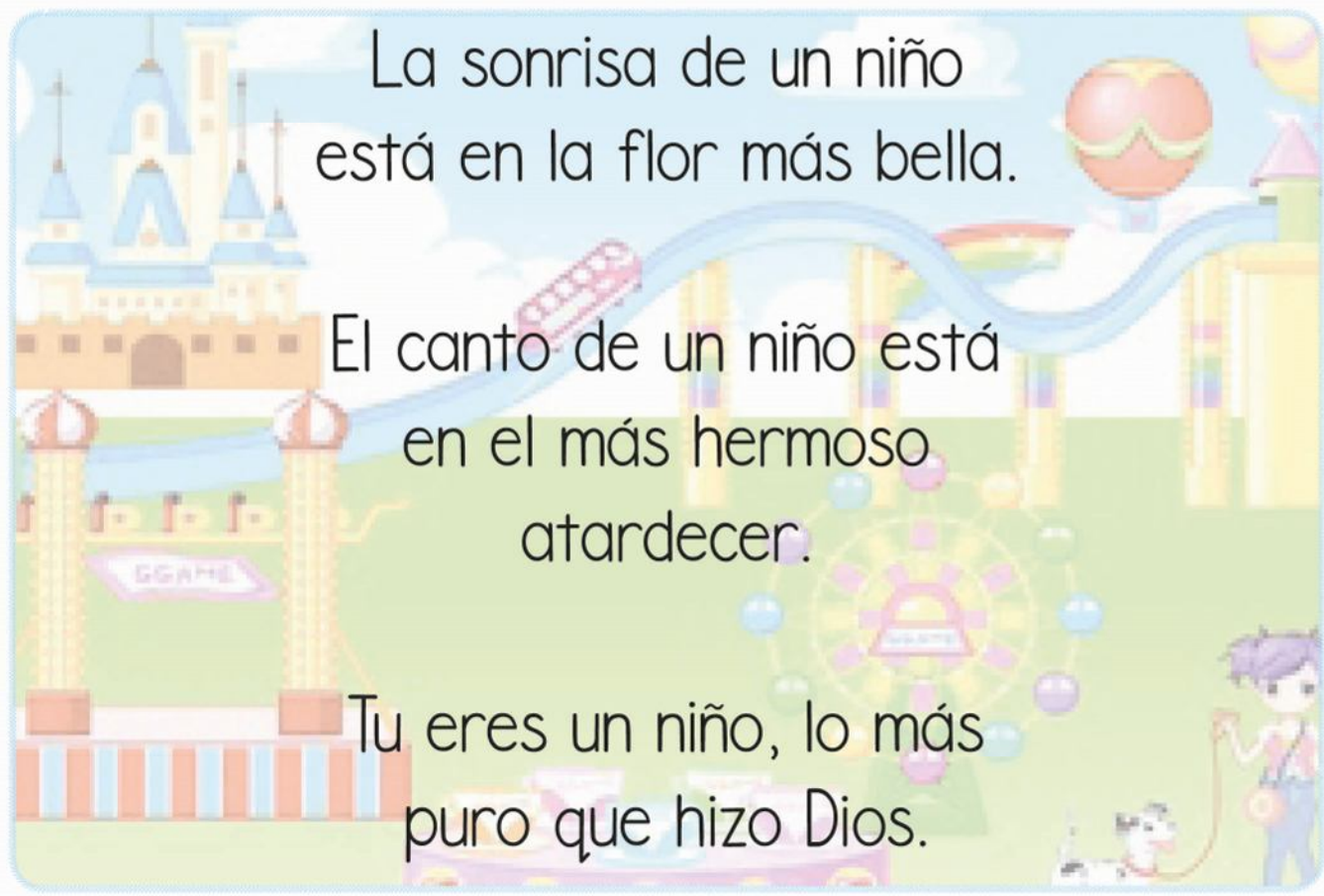



Mi nombre es: \_\_\_\_\_



# La hormiguita trabajadora

❖ Delinear con plumones y colorear los personajes del cuento.



















Mi nombre es: \_\_\_\_\_



❖ Lee con ayuda de tu profesora el cuento con soportes gráficos “La hormiguita trabajadora”.

Había una vez una  que era muy trabajadora. A ella le gustaba lavar, limpiar y recoger , y también le gustaba comer . Un día encontró en su jardín dos  a los que solo les gustaba jugar; entonces, las  les dijo: “¿Qué comerán si solo se dedican a jugar?”. Los  no le hicieron caso a la  y ella se enojó mucho. los  le dijeron que no se enoje, pero la  les respondió: “No me enoja porque jueguen, sino porque no tendrán comida para cuando venga la ”. Finalmente, los  entendieron, y después de jugar, recogieron .



Mi nombre es: \_\_\_\_\_



❖ Marca (X) un aspa la respuesta correcta.

1 ¿A quién le gustaba limpiar, lavar y comer pasteles?

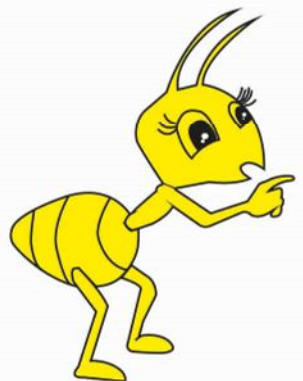

2 ¿Quiénes jugaban sin recoger semillas?

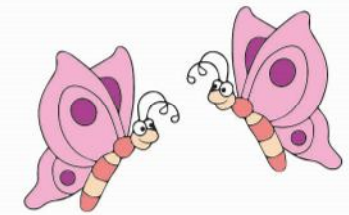
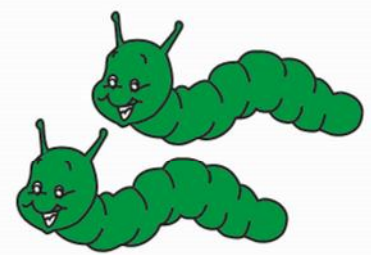
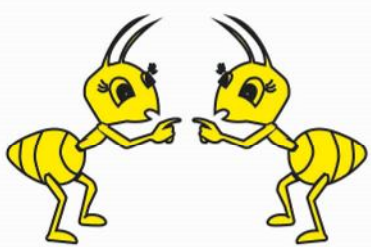



Mi nombre es: \_\_\_\_\_



# Figuras escondidas

❖ Pinta con tempera la pera que encuentres.

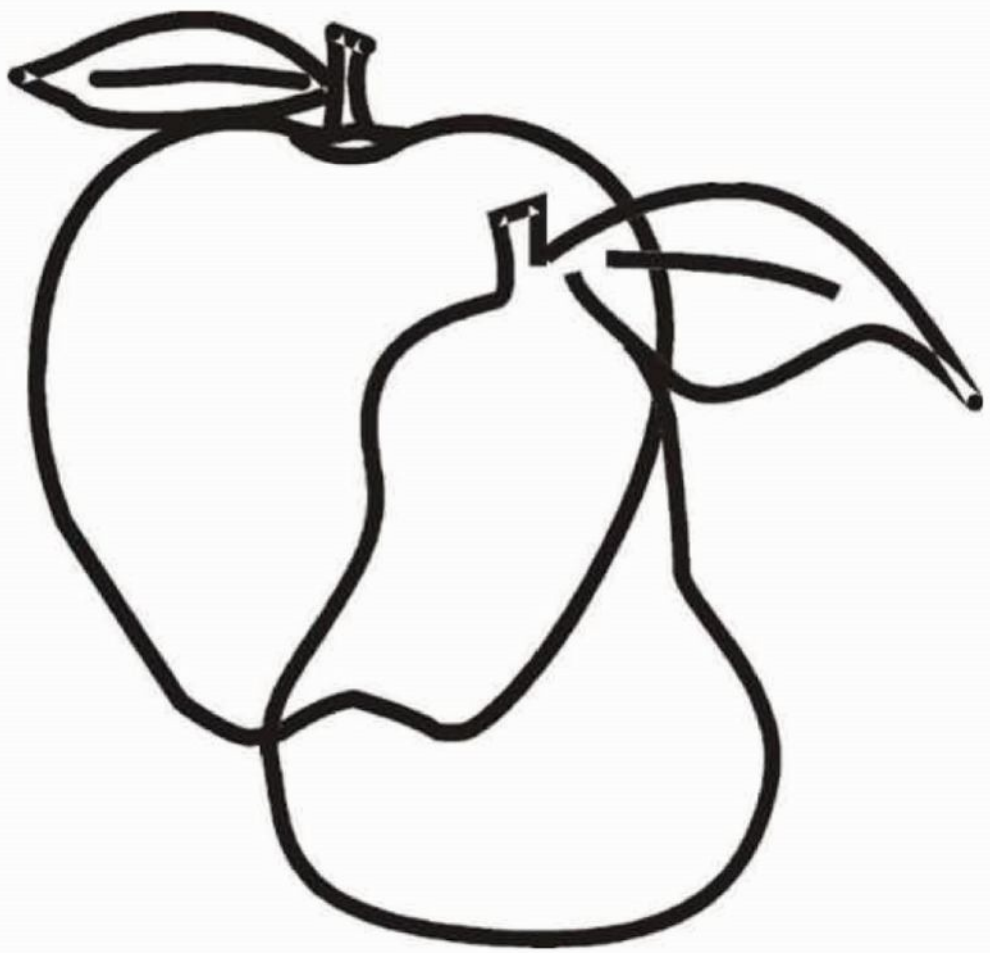



Mi nombre es: \_\_\_\_\_



❖ Rasga papel y pega en la imagen.

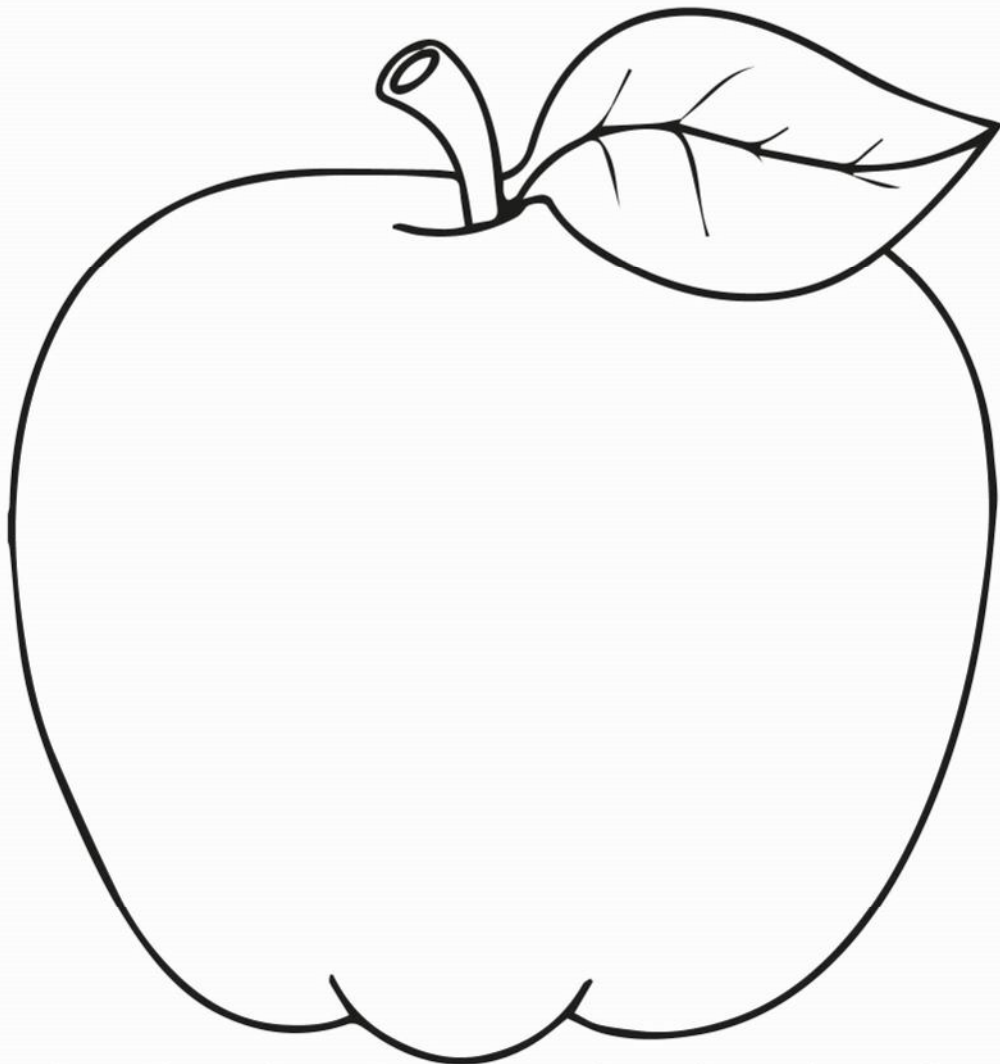



Mi nombre es: \_\_\_\_\_

--	--	--

❖ Razga papel de seda arrugadito; así tu gato está bonito.

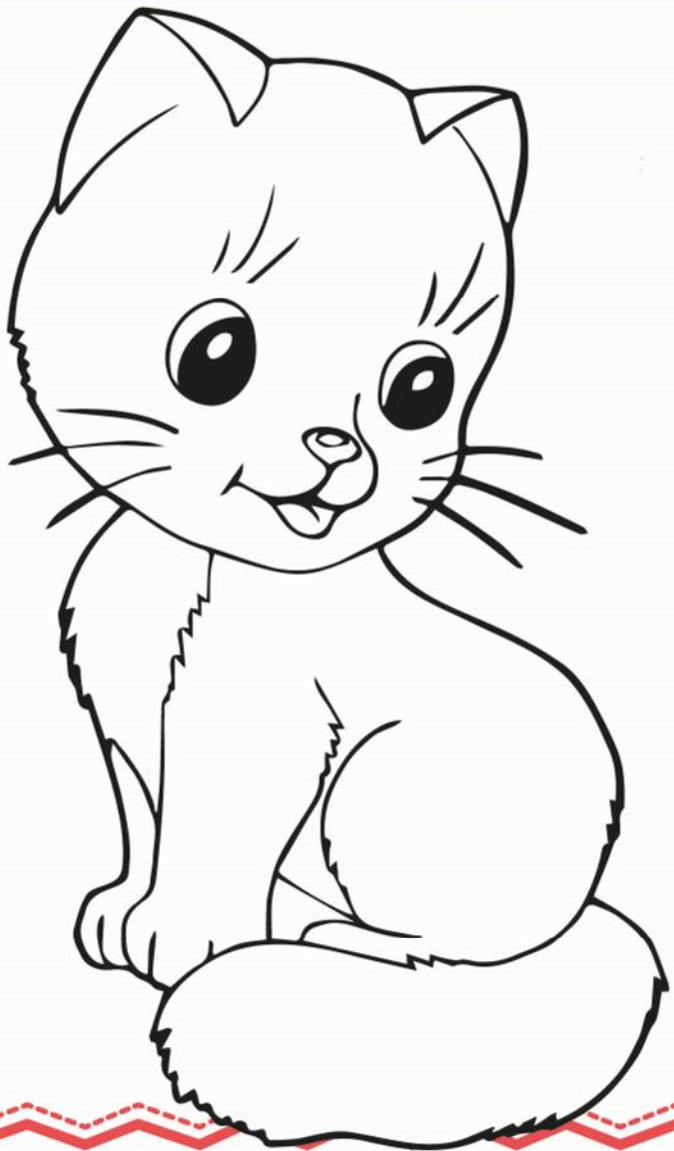



Mi nombre es: \_\_\_\_\_

--	--	--

## Actividad complementaria

### Me divierto y juego con la escritura

**Finalidad:**

- Hacer mas divertido la iniciación a la escritura.
- Desarrollar la coordinación motora gruesa

**Materiales:**

- Cinta Maskingtape
- Piso del Patio
- Niños

**Procedimiento:**

Realizamos trazos con las tizas en el piso del patio (Rectos, oblicuos, curvos en zig zag).

- \* Los niños pueden pasar caminando, saltando, gateando solos o en grupo.
- \* Los trazos deben ser largos para que e juego sea mas divertido.





Mi nombre es: \_\_\_\_\_



# GRAFONOTRICIDAD

## 3 AÑOS



















Mi nombre es: \_\_\_\_\_

--	--	--

❖ Une los puntos con plumón grueso, siguiendo las flechas.

						
						
-----	-----	-----	-----	-----	-----	-----
●	●	●	●	●	●	●





Mi nombre es: \_\_\_\_\_

--	--	--

❖ Sigue el camino de las flechas, con crayola.

Tracing practice area featuring 15 vertical dashed lines. Each line starts with a red arrow pointing downwards and ends with a red dot at the bottom. The lines are arranged in two groups: the first group has 8 lines, and the second group has 7 lines.





Mi nombre es: \_\_\_\_\_



Repasa las líneas siguiendo la dirección que indica la flecha.

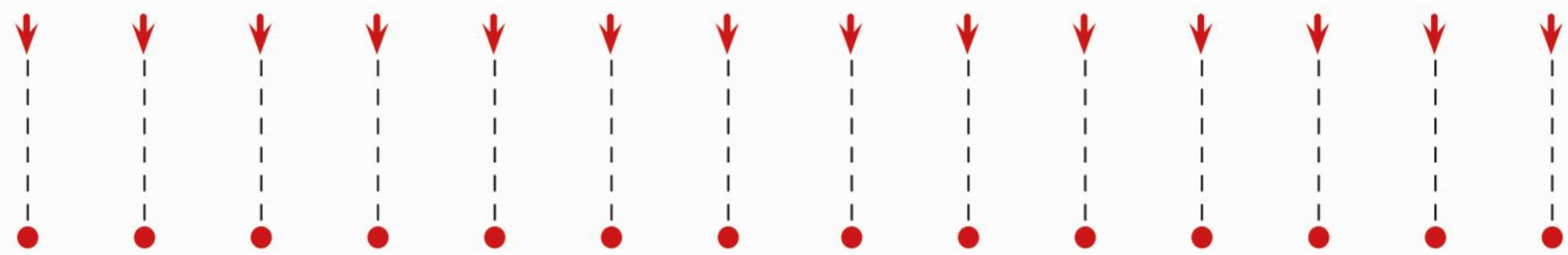
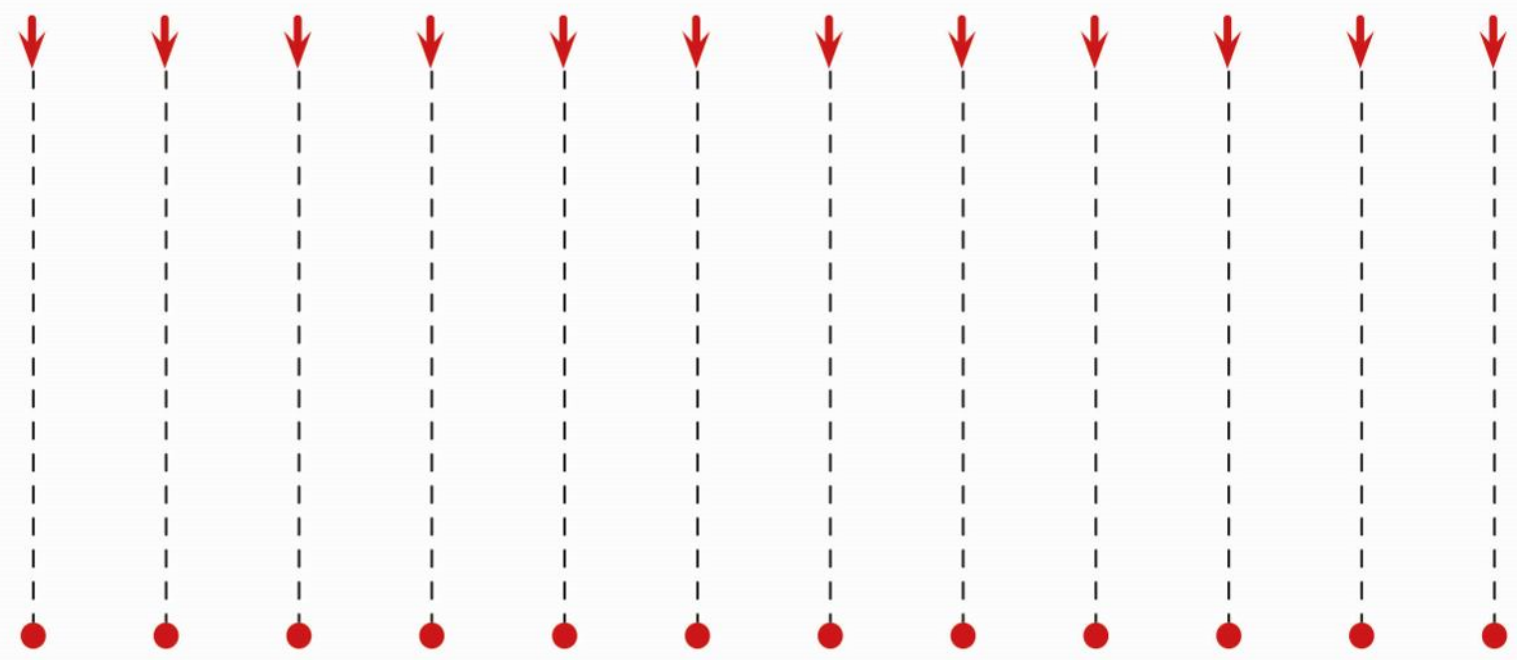



Mi nombre es: \_\_\_\_\_



❖ Repasa las líneas de arriba a bajo.

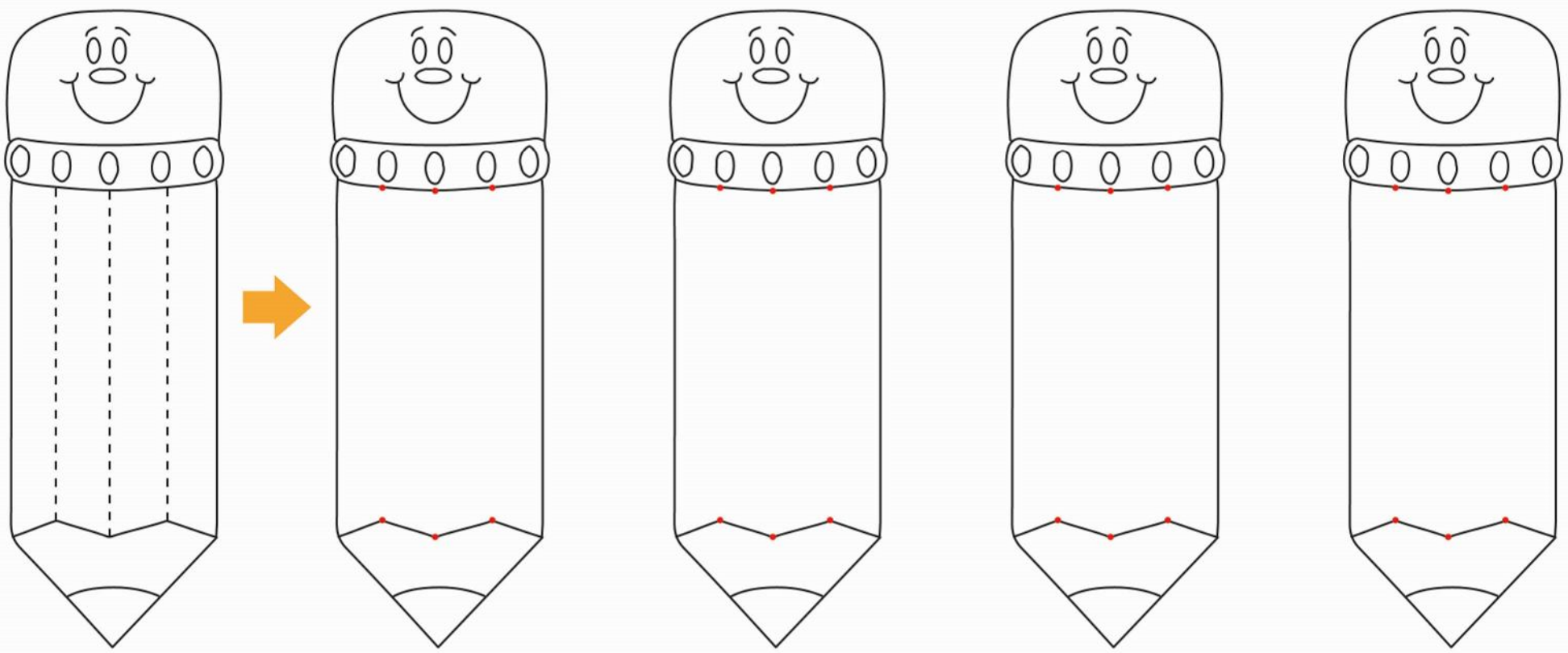



Mi nombre es: \_\_\_\_\_

--	--	--

❖ Traza con crayola de diferentes colores cada recorrido de arriba hacia abajo.

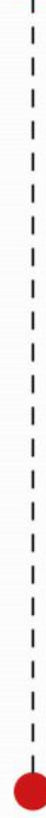
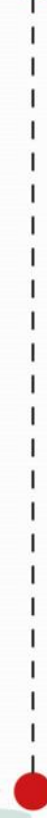
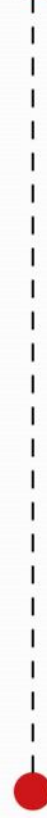



Mi nombre es: \_\_\_\_\_



❖ Unir de izquierda a derecha.

A series of six rows for tracing practice. Each row consists of a solid blue top line, a dashed black middle line, and a solid blue bottom line. On the left side of each row is a small illustration of a white rabbit. On the right side of each row is a small illustration of a carrot. A red dot is placed at the end of the dashed line on both the left (near the rabbit) and the right (near the carrot), with a red arrow pointing from the left dot to the right dot, indicating the direction of the tracing stroke.



Mi nombre es: \_\_\_\_\_

--	--	--

◆ Delinear el camino de las aves.

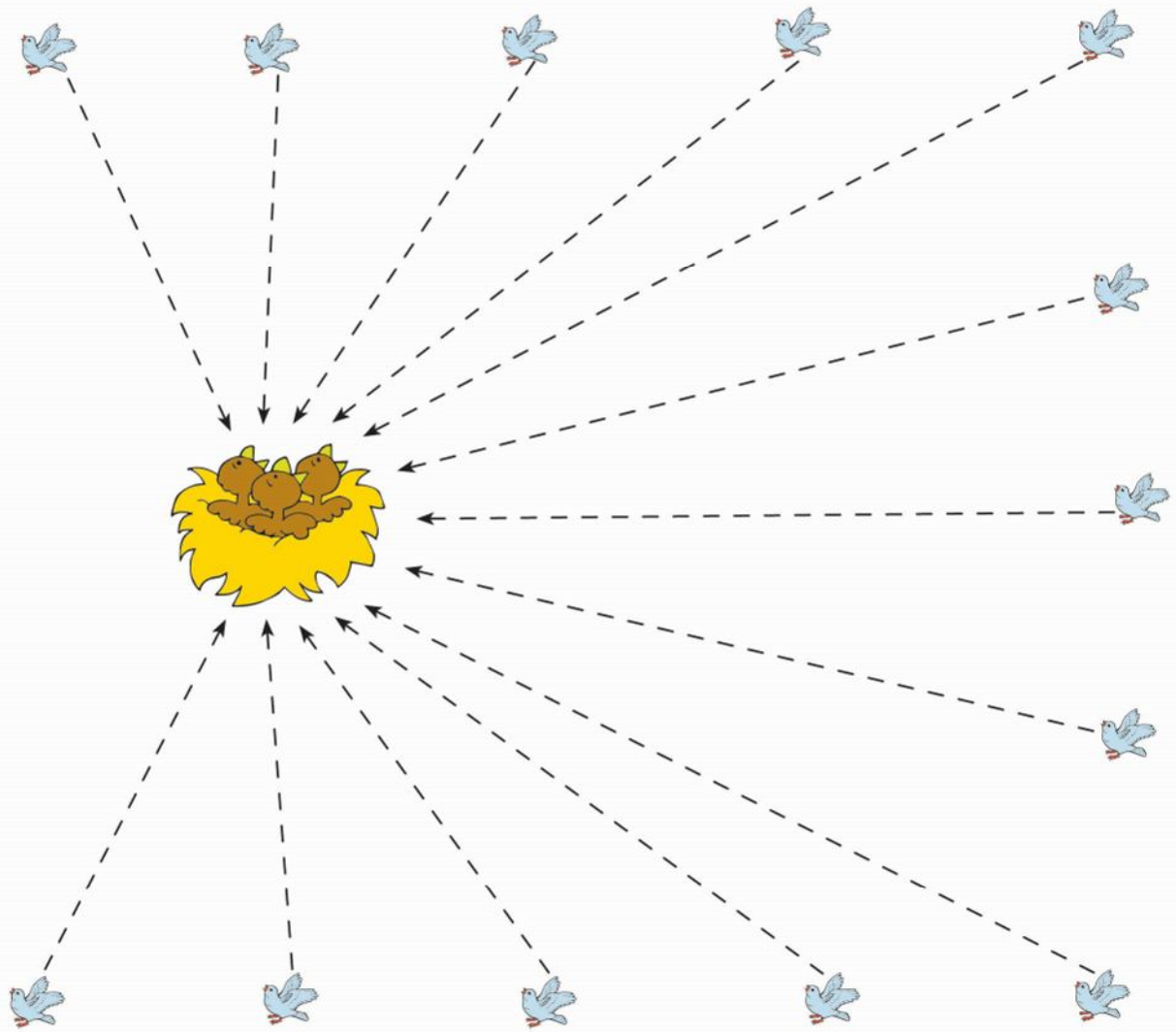



Mi nombre es: \_\_\_\_\_

--	--	--

❖ Delinear el trazo.





Mi nombre es: \_\_\_\_\_



❖ Une los puntos con crayola de izquierda a derecha.







Mi nombre es: \_\_\_\_\_



❖ Repasa con plumón las líneas entrecortadas.

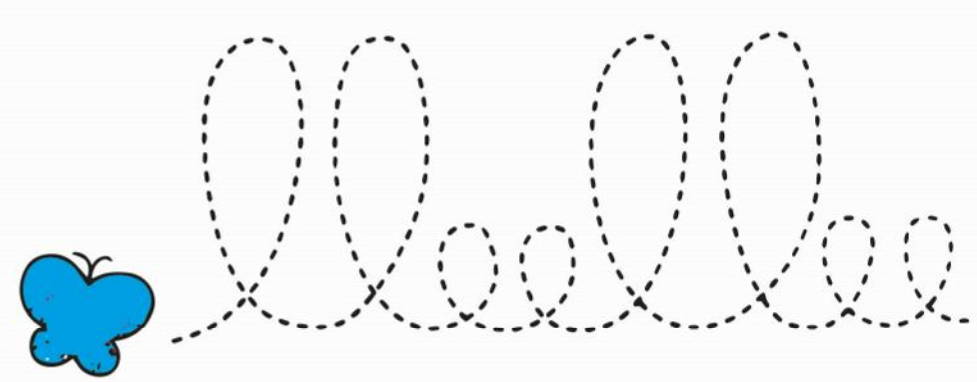
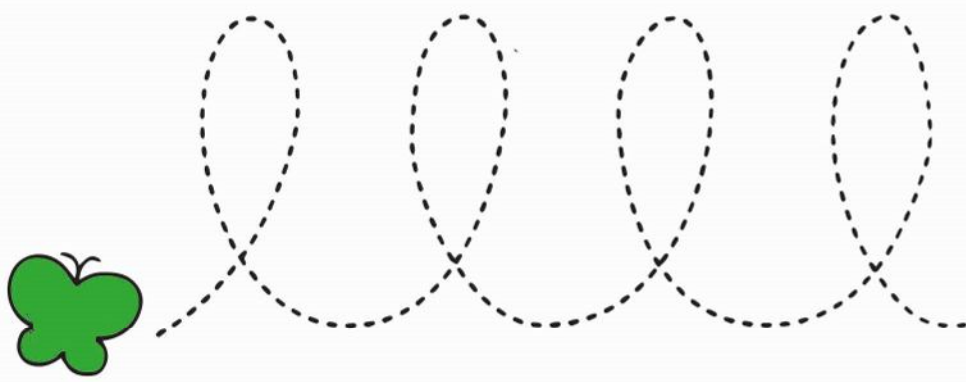
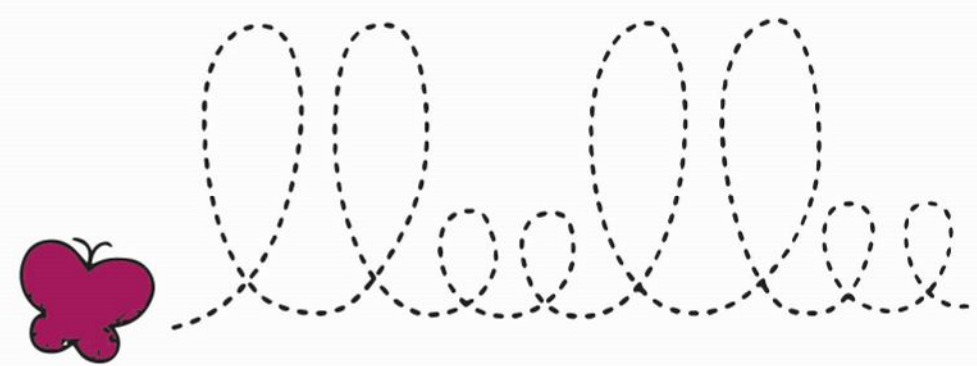
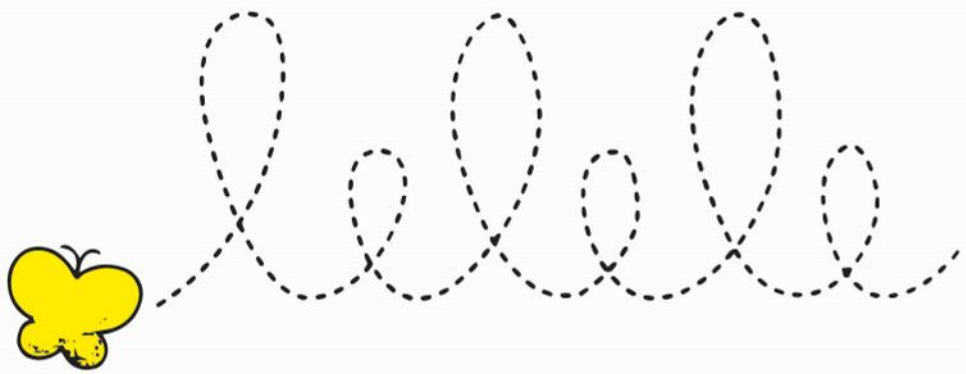



Mi nombre es: \_\_\_\_\_

--	--	--

❖ Traza con crayola de diferentes colores cada recorrido de arriba hacia abajo.

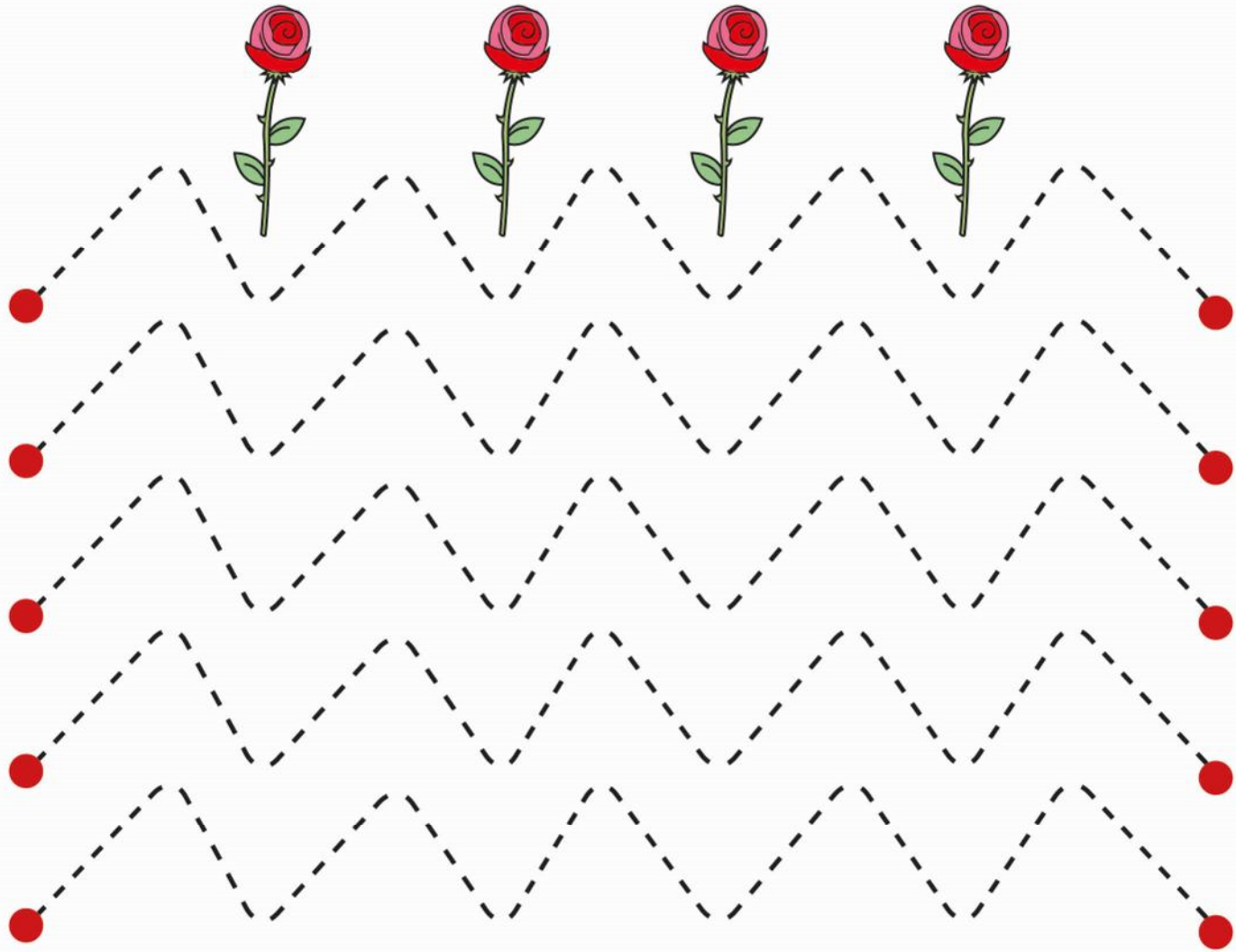



Mi nombre es: \_\_\_\_\_

--	--	--

❖ Traza las líneas entrecortadas.



Mi nombre es: \_\_\_\_\_

\_\_\_\_\_

◆ Delinear:

Tracing practice for the letter 'C'. Each row features a cartoon girl on the left, a dashed outline of the letter 'C' in the middle, and a drum on the right. A red dot is placed at the bottom of the 'C' outline, and another red dot is placed at the bottom of the drum. The dashed lines are intended for a child to trace the shape of the letter 'C'.



Mi nombre es: \_\_\_\_\_



◆ Delinear el recorrido de las niñas.

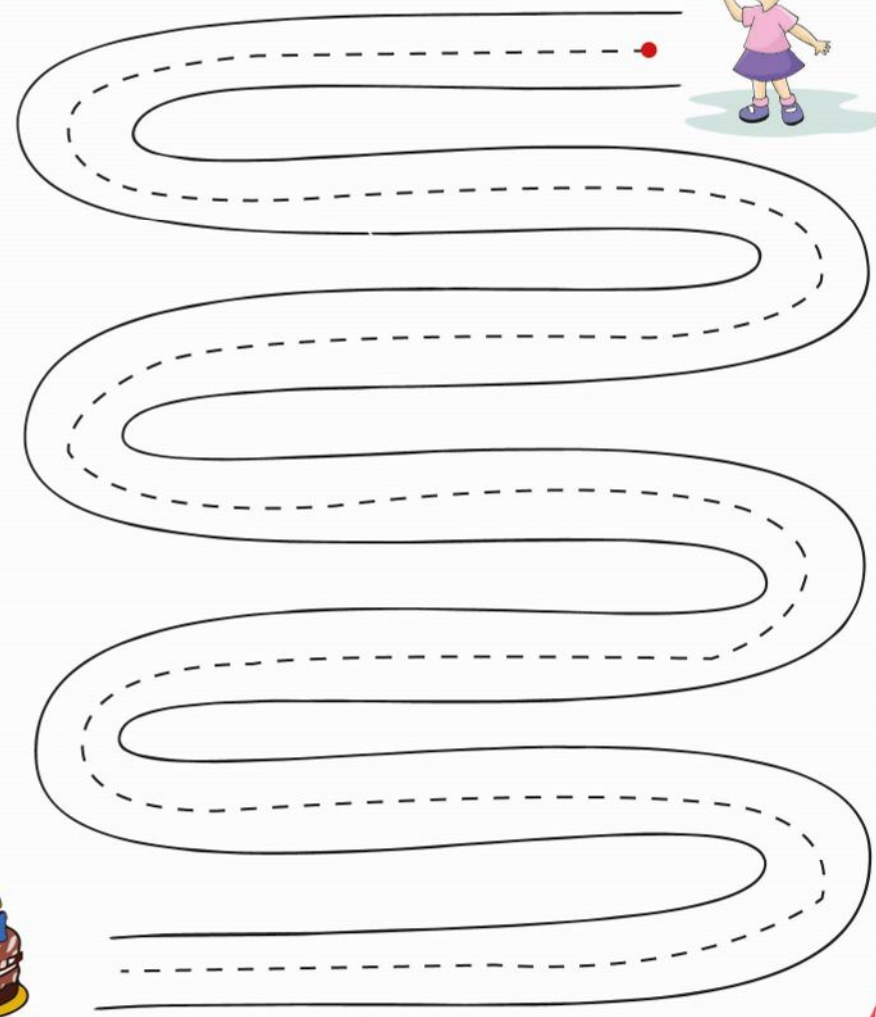
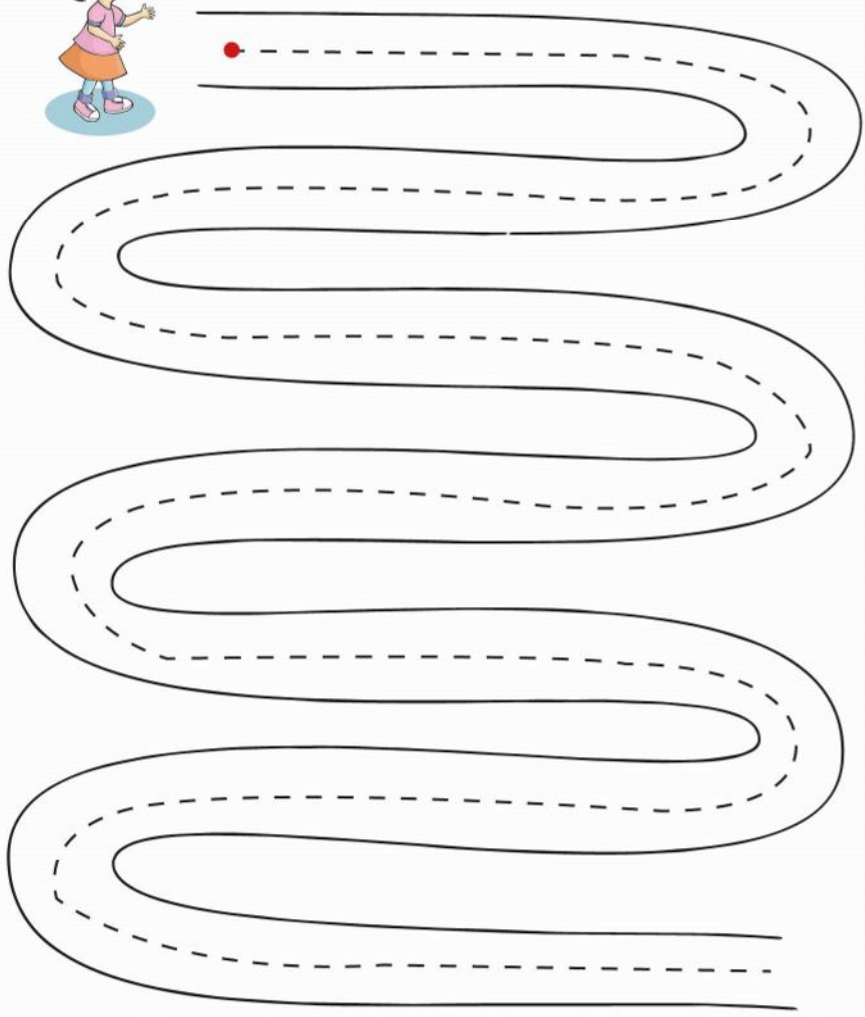



Mi nombre es: \_\_\_\_\_

--	--	--

❖ Traza con crayola de diferentes colores cada recorrido de arriba hacia abajo.

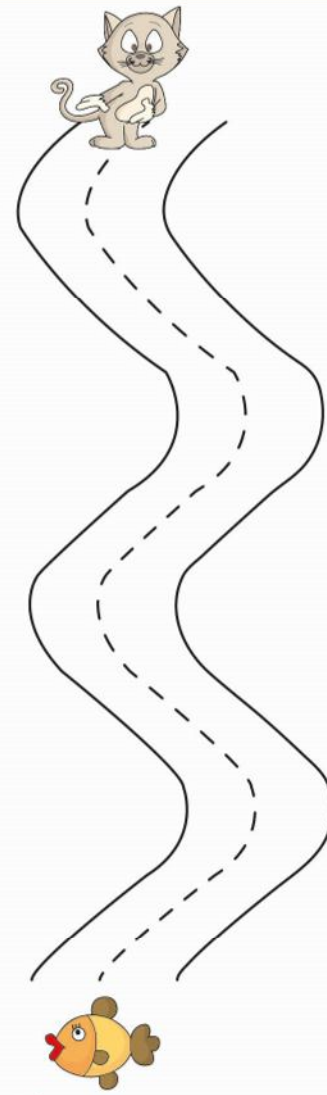
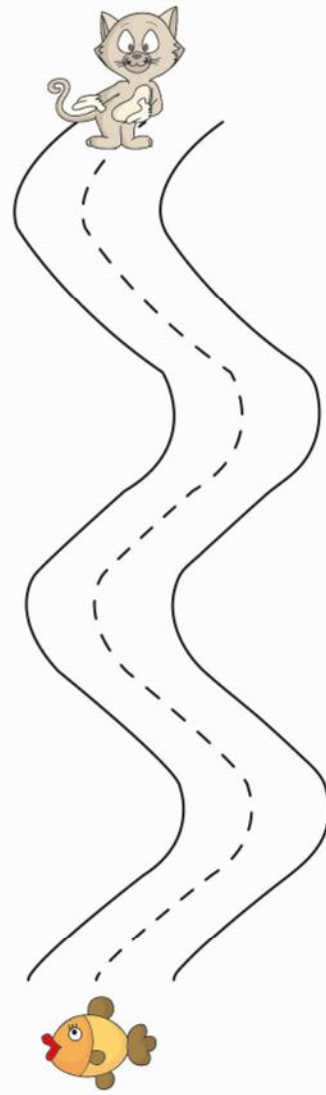
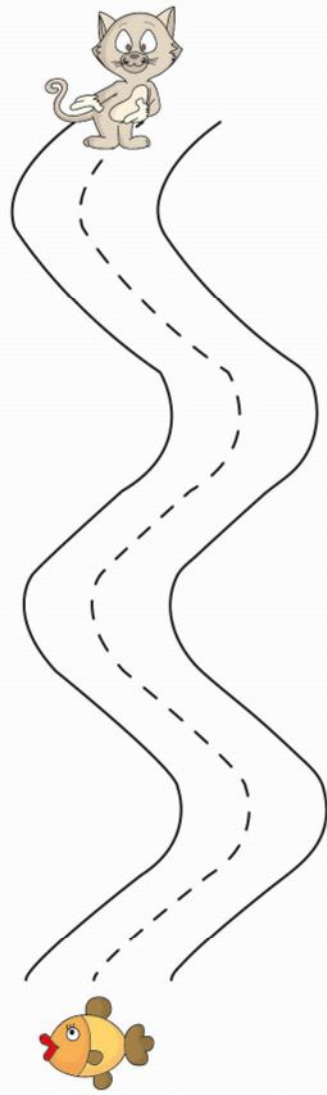
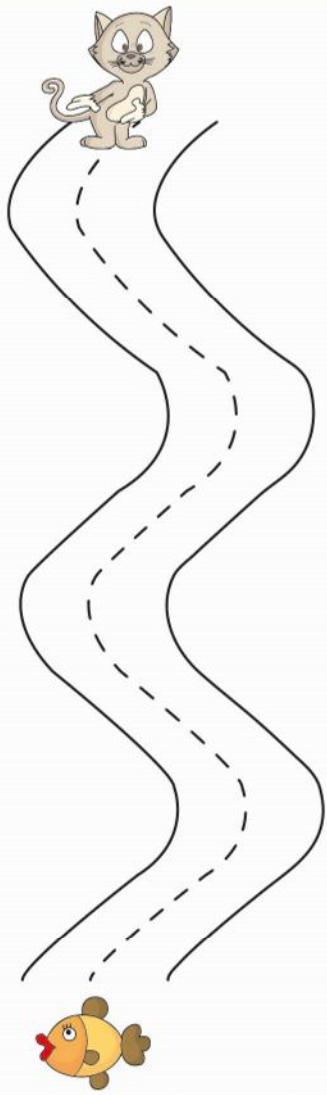



Mi nombre es: \_\_\_\_\_

Three empty rectangular boxes for writing a name.

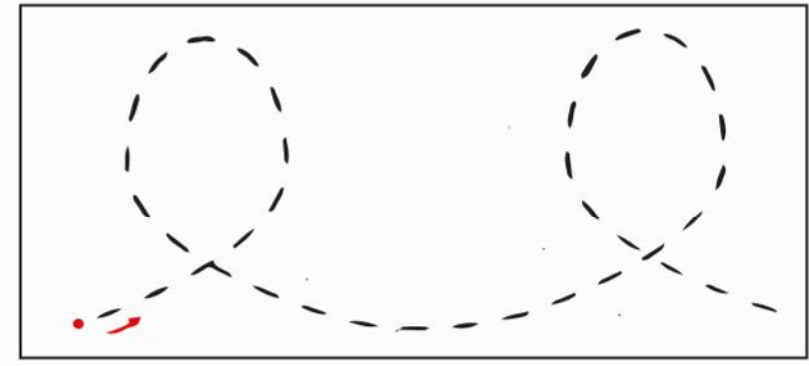
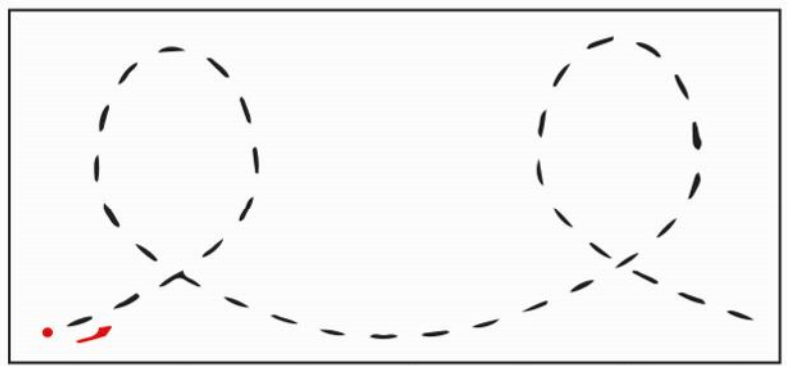
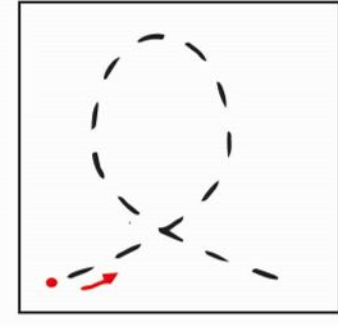
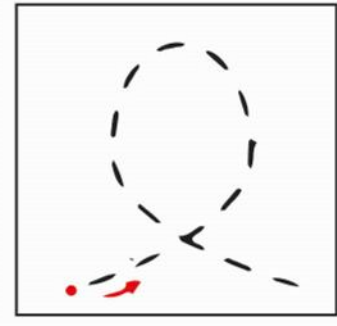
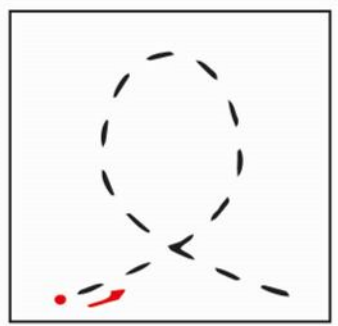
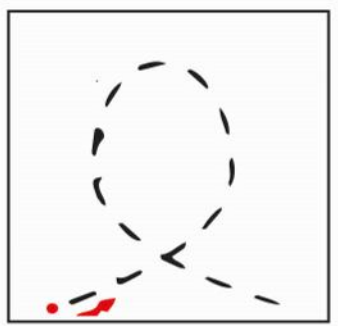
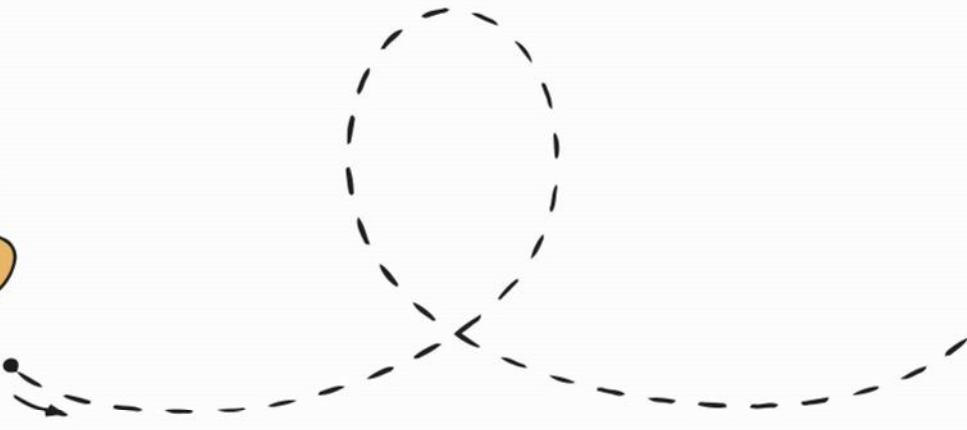
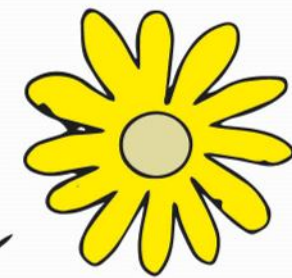
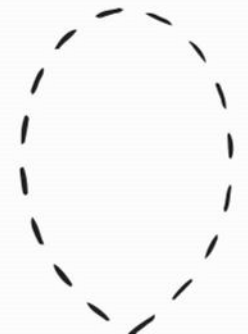



Mi nombre es: \_\_\_\_\_

--	--	--

❖ Realiza el trazo con plumón grueso.

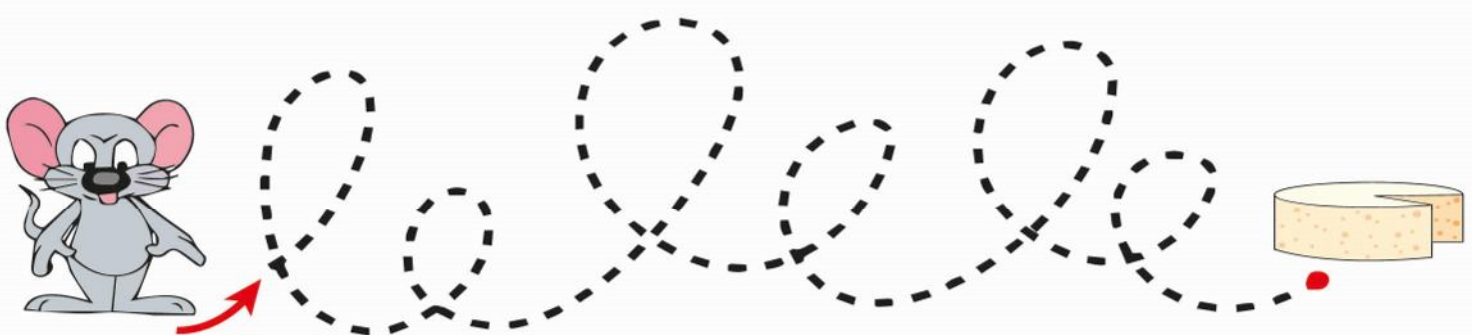
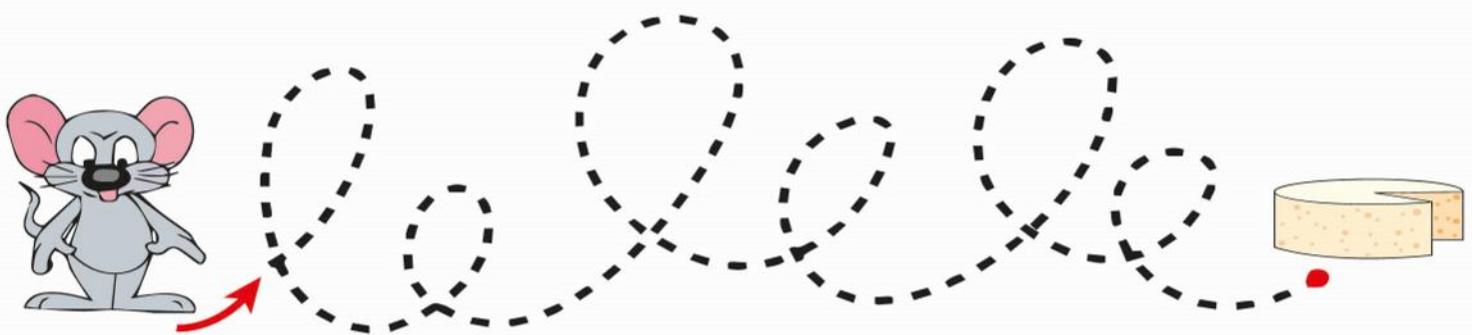
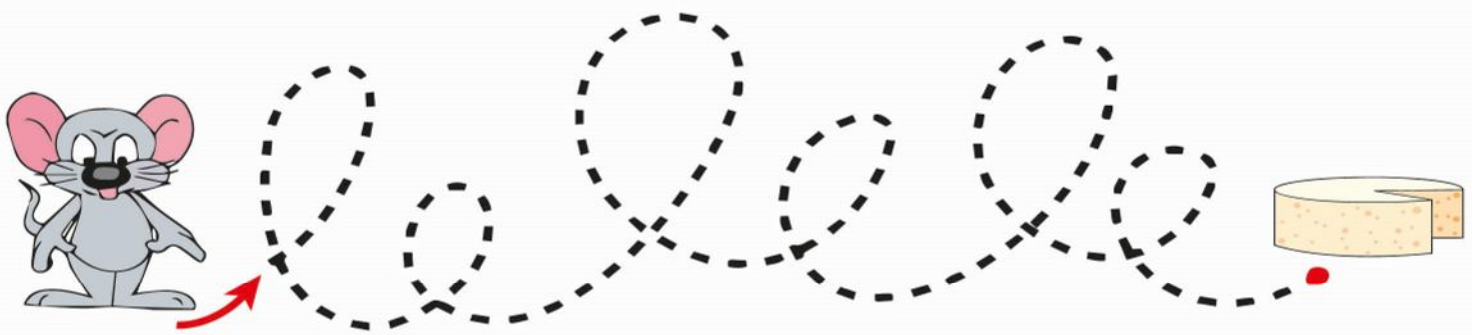





Mi nombre es: \_\_\_\_\_

Three empty rectangular boxes for writing.

◆ Delinear:





Mi nombre es: \_\_\_\_\_

Three empty rectangular boxes for writing a name.

Clase de Clases JB

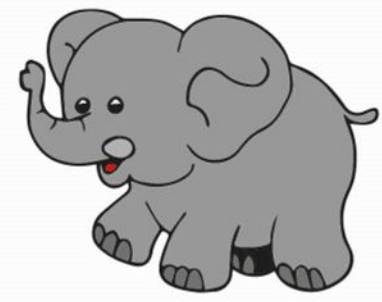
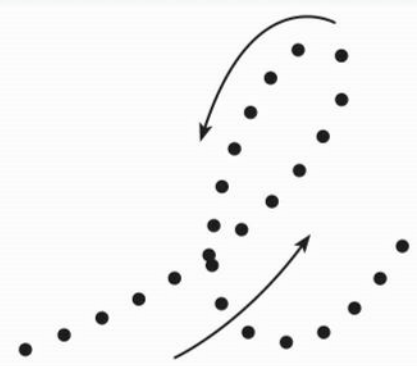

elefante





Mi nombre es: \_\_\_\_\_

--	--	--

❖ Traza el camino del gusanito.

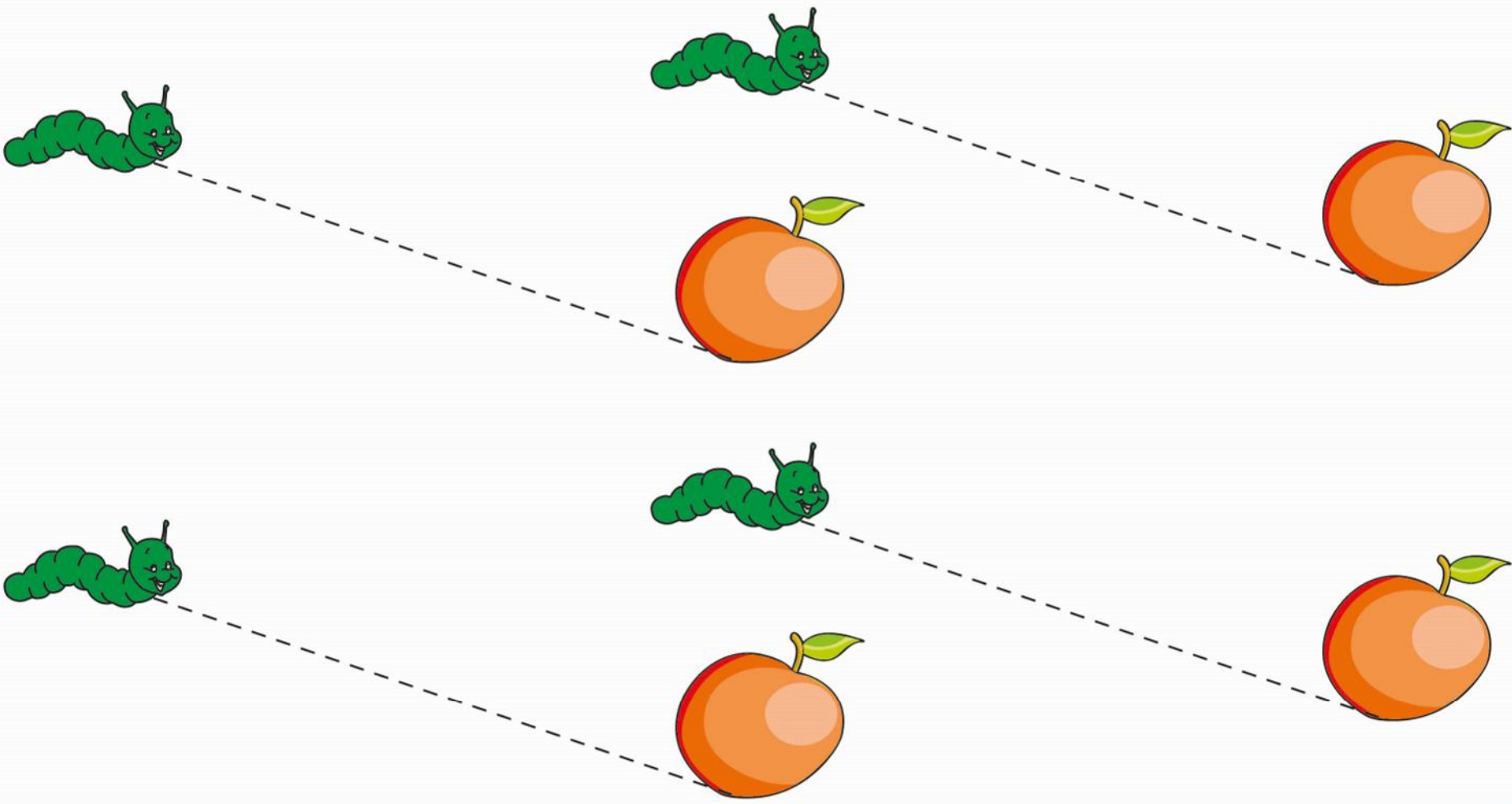



Mi nombre es: \_\_\_\_\_

--	--	--

◆ Delinear el trazo.

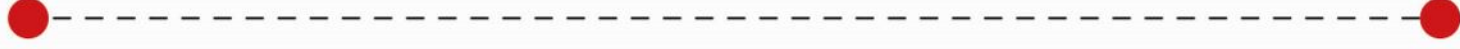



Mi nombre es: \_\_\_\_\_

--	--	--

❖ Delinear.

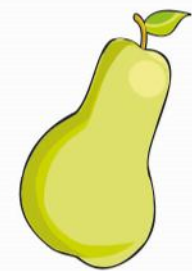
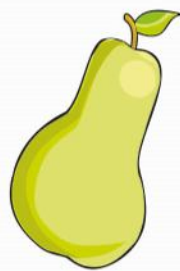
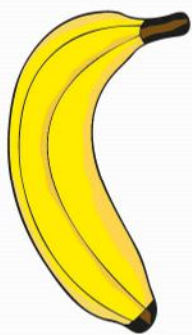



Mi nombre es: \_\_\_\_\_

--	--	--

◆ Une los puntos con crayola de izquierda a derecha.

Tracing practice box 1: A dolphin illustration on the left, followed by a rectangular box containing a horizontal dashed line with red dots at both ends and an arrow pointing right from the first dot.

Tracing practice box 2: A dolphin illustration on the left, followed by a rectangular box containing a horizontal dashed line with red dots at both ends and an arrow pointing right from the first dot.

Tracing practice box 3: A dolphin illustration on the left, followed by a rectangular box containing a horizontal dashed line with red dots at both ends and an arrow pointing right from the first dot.

Tracing practice box 4: A dolphin illustration on the left, followed by a rectangular box containing a horizontal dashed line with red dots at both ends and an arrow pointing right from the first dot.



Mi nombre es: \_\_\_\_\_

--	--	--

◆ Delinear.





Mi nombre es: \_\_\_\_\_

--	--	--

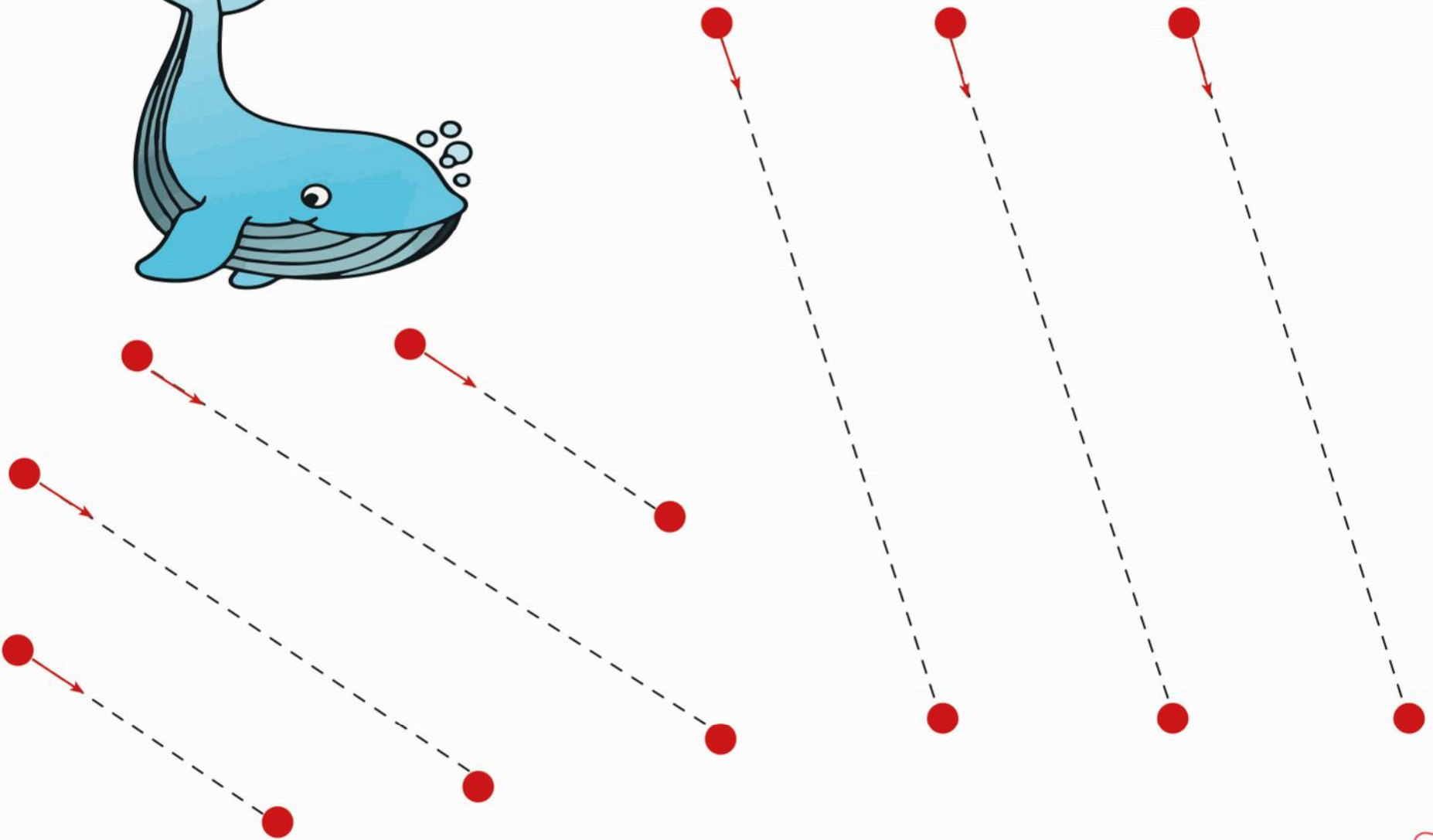
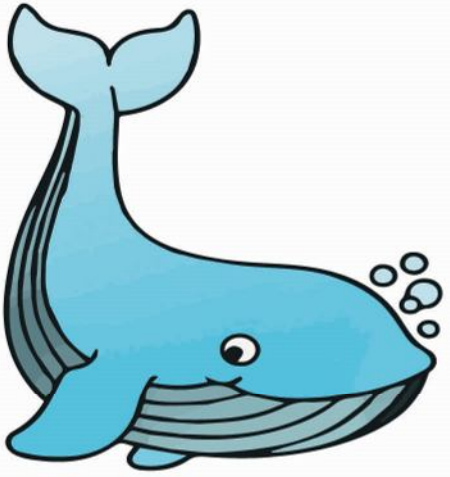





Mi nombre es: \_\_\_\_\_



Delinear.





Mi nombre es: \_\_\_\_\_

\_\_\_\_\_

◆ Unir de izquierda a derecha.





Mi nombre es: \_\_\_\_\_

\_\_\_\_\_

◆ Unir de izquierda a derecha.

Four rows of handwriting practice. Each row consists of two solid blue horizontal lines with a dashed black line in the middle. A red arrow on the left points to the start of the dashed line, and a red dot on the right marks the end. On the far left of each row is a cartoon dog, and on the far right is a cartoon cat.



Mi nombre es: \_\_\_\_\_

Three empty rectangular boxes for writing.

◆ Une los puntos con crayola de izquierda a derecha.



A horizontal dashed line with a red dot at the left end and an arrow pointing right.

A horizontal dashed line with a red dot at the left end and an arrow pointing right.



A horizontal dashed line with a red dot at the left end and an arrow pointing right.

A horizontal dashed line with a red dot at the left end and an arrow pointing right.





Mi nombre es: \_\_\_\_\_



◆ Delinear:





f Guía de Clases JB



# Personal Social



Mi nombre es: \_\_\_\_\_

# ¡Bienvenido a un mundo de diversiones!

◆ Decora libremente.





Mi nombre es: \_\_\_\_\_



# ¿Quién soy yo?

❖ Pego mi foto y decoro el marco libremente.

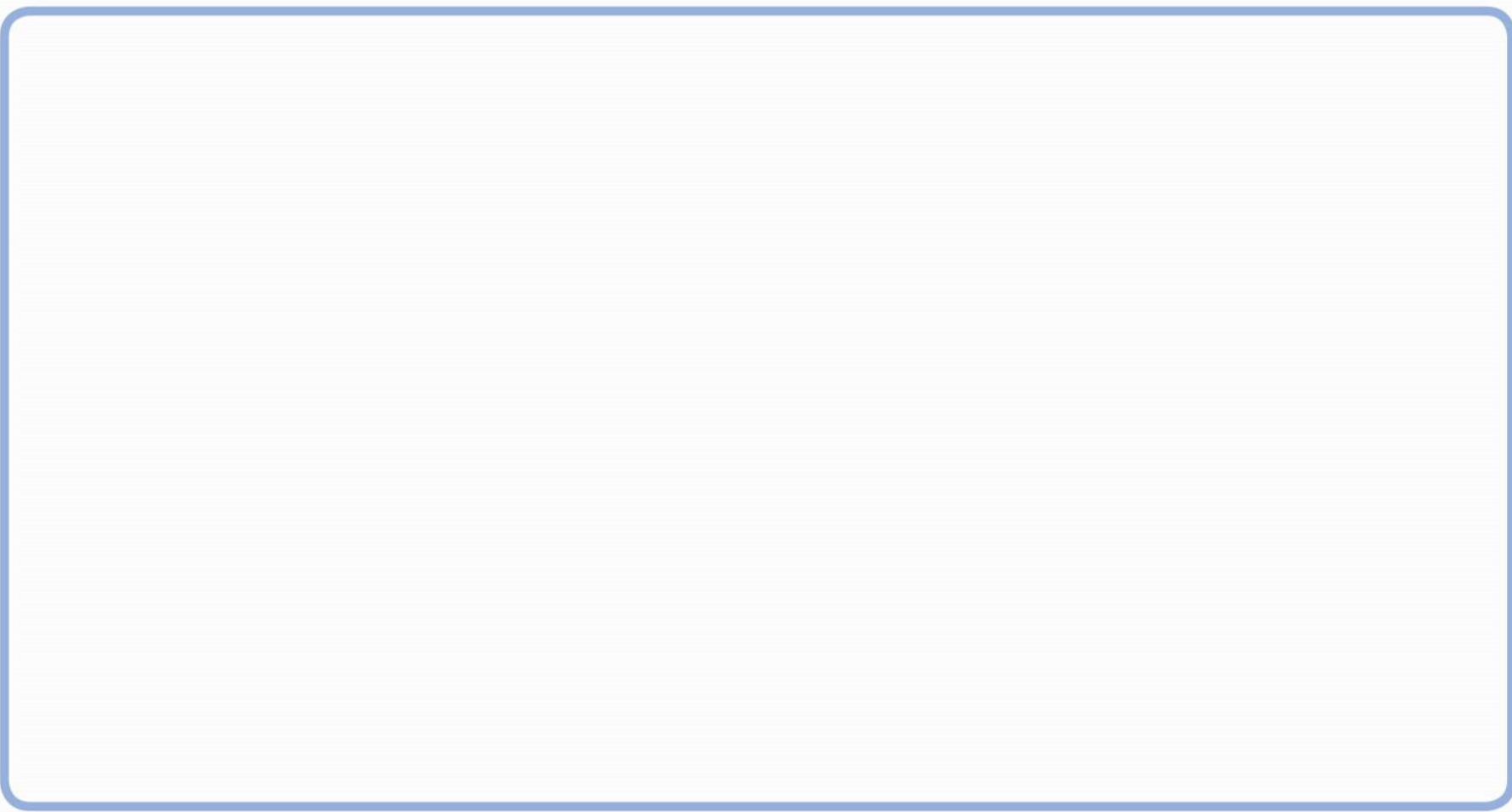



Mi nombre es: \_\_\_\_\_



# Identidad sexual

❖ Colorea con t mpera al que se parece a ti: utiliza tu dedo  ndice.

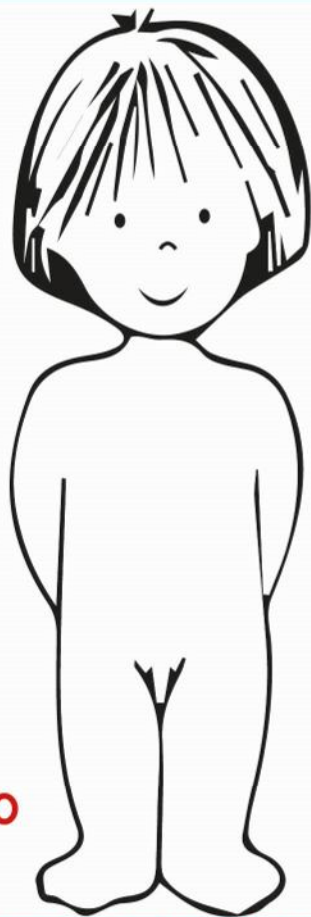

Ni o

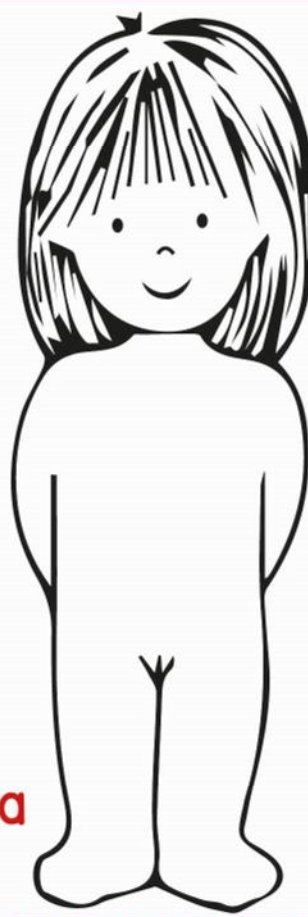

Ni a

Nuestro cuerpo es hermoso, Dio lo ha creado por eso hay ni os y ni as. Los ni os se diferencian por tener un pene y las ni as por tener una vagina, son partes  ntimas que deben ser muy bien cuidadas.



Mi nombre es: \_\_\_\_\_



# ¿Qué me pongo?

❖ Con una línea relaciona las prendas de vestir según sea niño o niña.

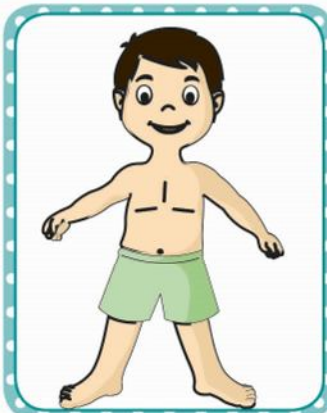
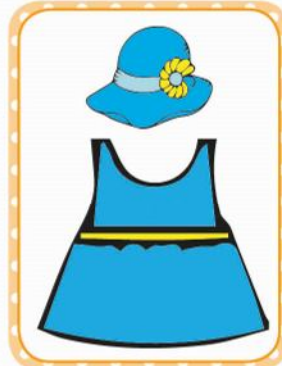
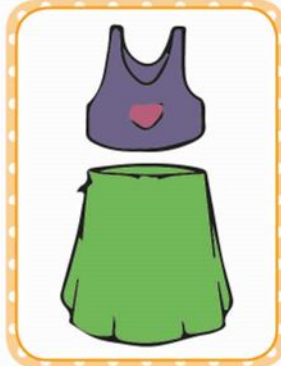



Mi nombre es: \_\_\_\_\_

\_\_\_\_\_

# Datos personales

Con ayuda de tus papitos completa tus datos personales y pega tu foto.



Mi nombre es:

\_\_\_\_\_



# Información complementaria



Mi número de DNI es:

\_\_\_\_\_



Mi mamá se llama:

\_\_\_\_\_

Mi papá se llama:

\_\_\_\_\_



Soy alérgico a:

\_\_\_\_\_



Me gusta:

\_\_\_\_\_



Mi nombre es: \_\_\_\_\_

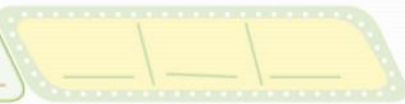

# Mi jardín

◆ Colorea con t mpera tu colegio, utiliza tu dedo  ndice.

C A R M E L I T A S K I D ' S

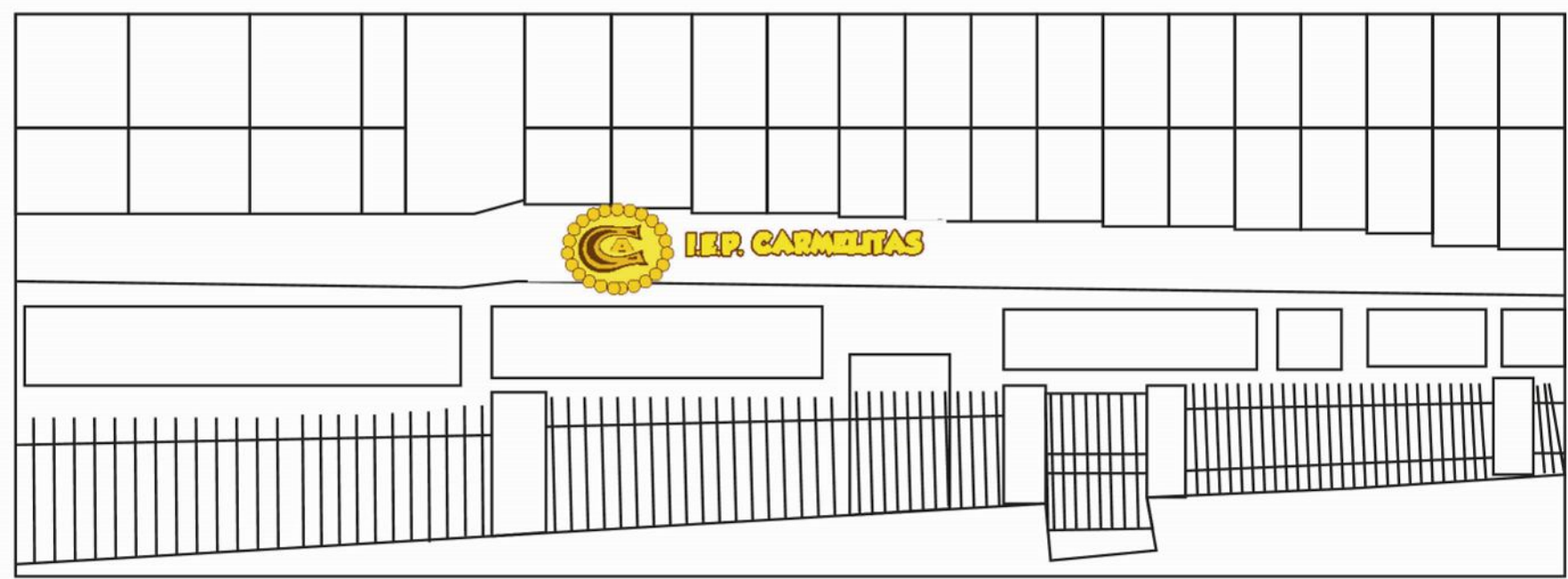

Mi nombre es: \_\_\_\_\_



# En la escuela puedes...



Escucha con atención a tu maestra y conversa sobre las imágenes que observa.



## Explorar



## Pintar

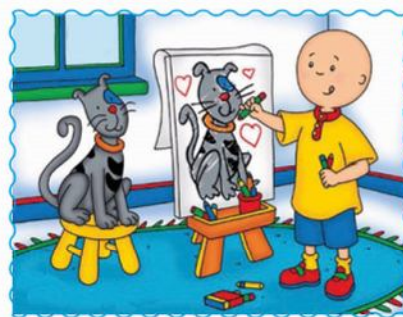

## Jugar



## Pensar y dialogar





Mi nombre es: \_\_\_\_\_

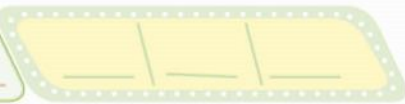

# Palabras mágicas

❖ Con ayuda de tu profesora recorta la página siguiente y pega según te indique.

Por favor

Gracias

Buenos días

Disculpa

Permiso

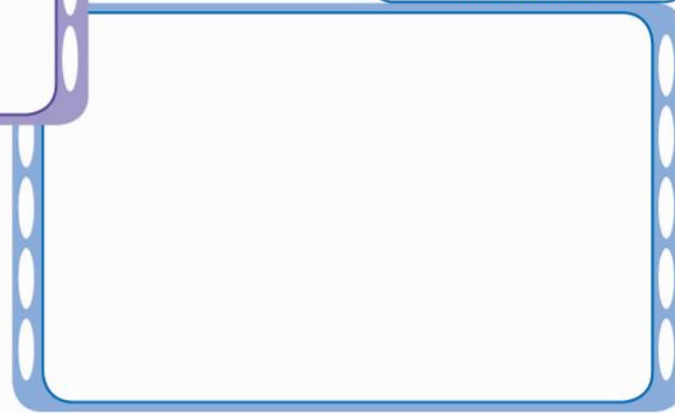
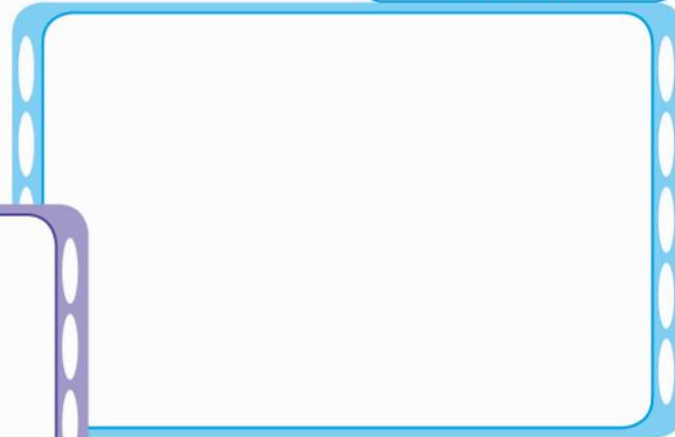



Mi nombre es: \_\_\_\_\_

\_\_\_\_\_

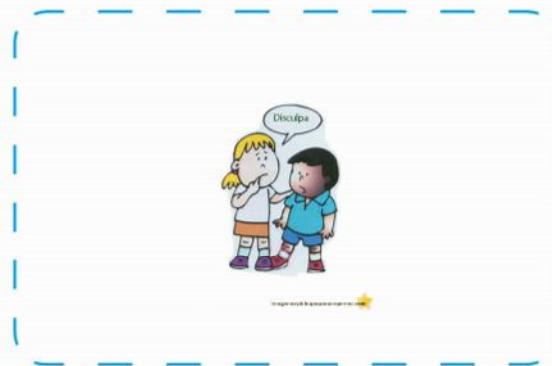





Mi nombre es: \_\_\_\_\_

\_\_\_\_\_

# Normas de convivencia

❖ Colorea con crayola y decora el borde con serpentina.

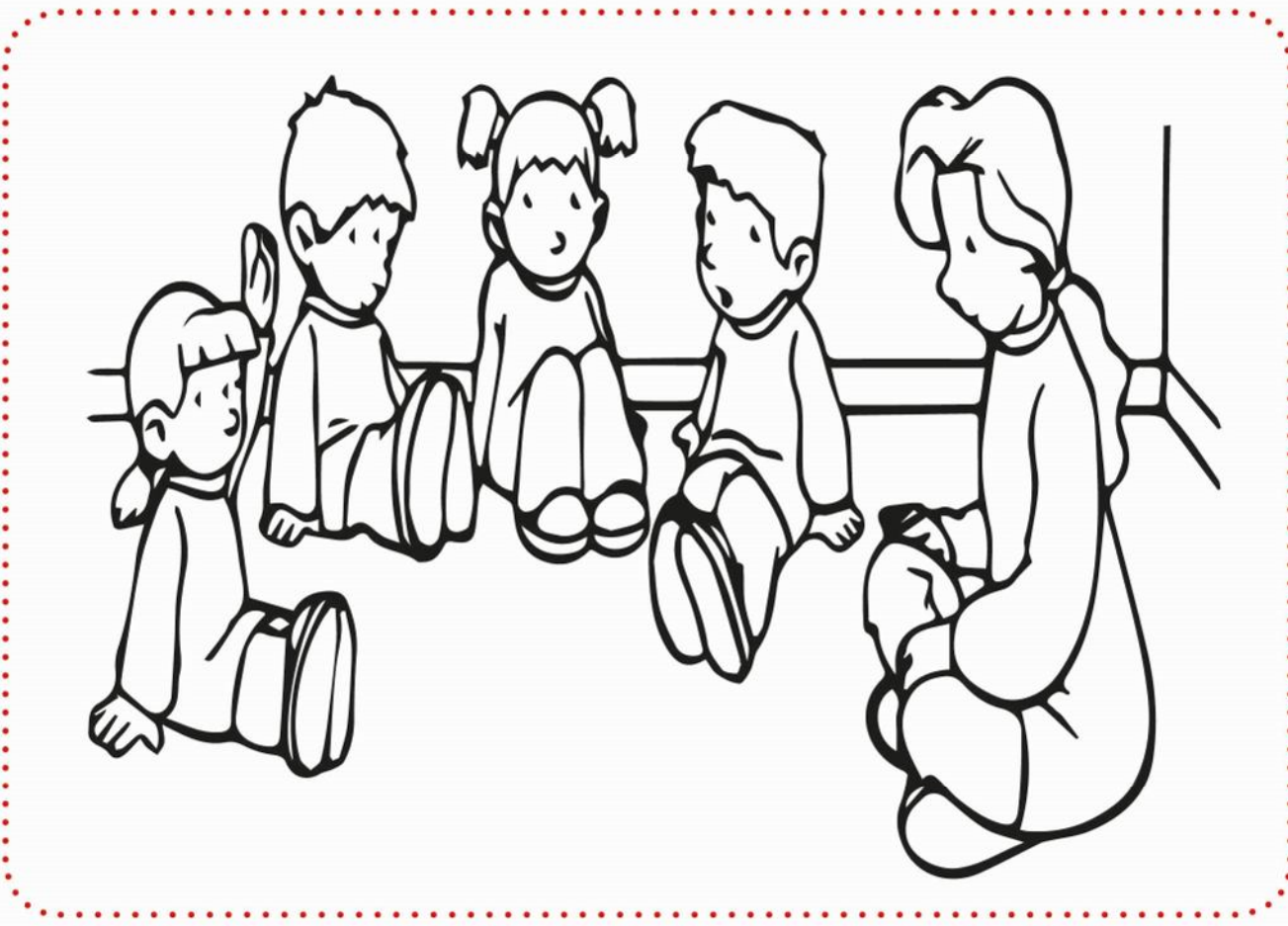



Mi nombre es: \_\_\_\_\_



◆ Colorea con crayola a los niños, a la maestra píntala con hisopo y t mpera del color que desees.





Mi nombre es: \_\_\_\_\_

--	--	--

❖ Decora libremente y dialoga con tu maestra, recordando los momentos en el que esperas tu turno.

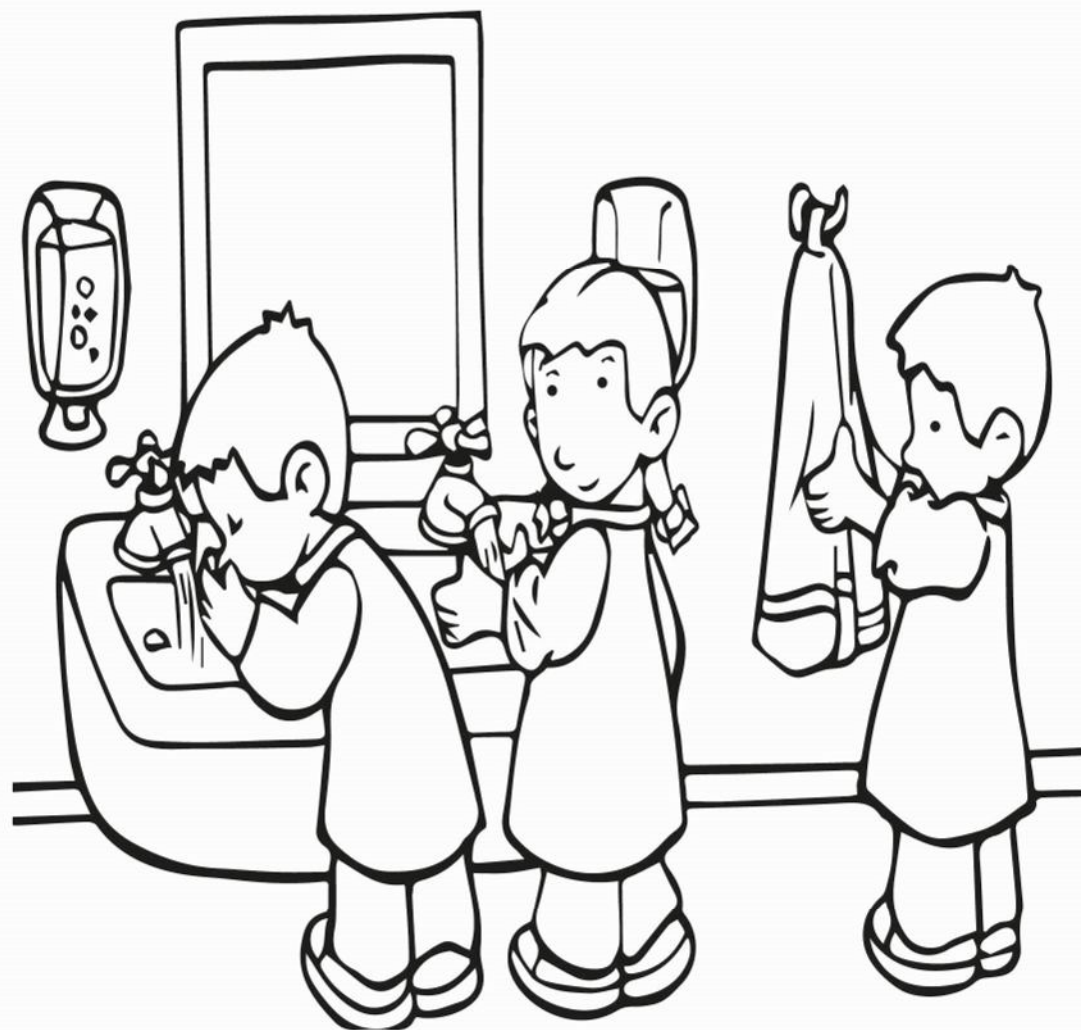



Mi nombre es: \_\_\_\_\_

--	--	--

◆ Colorea y decora con plumón grueso y recuerda cuál es tu amigo con el que más compartes.

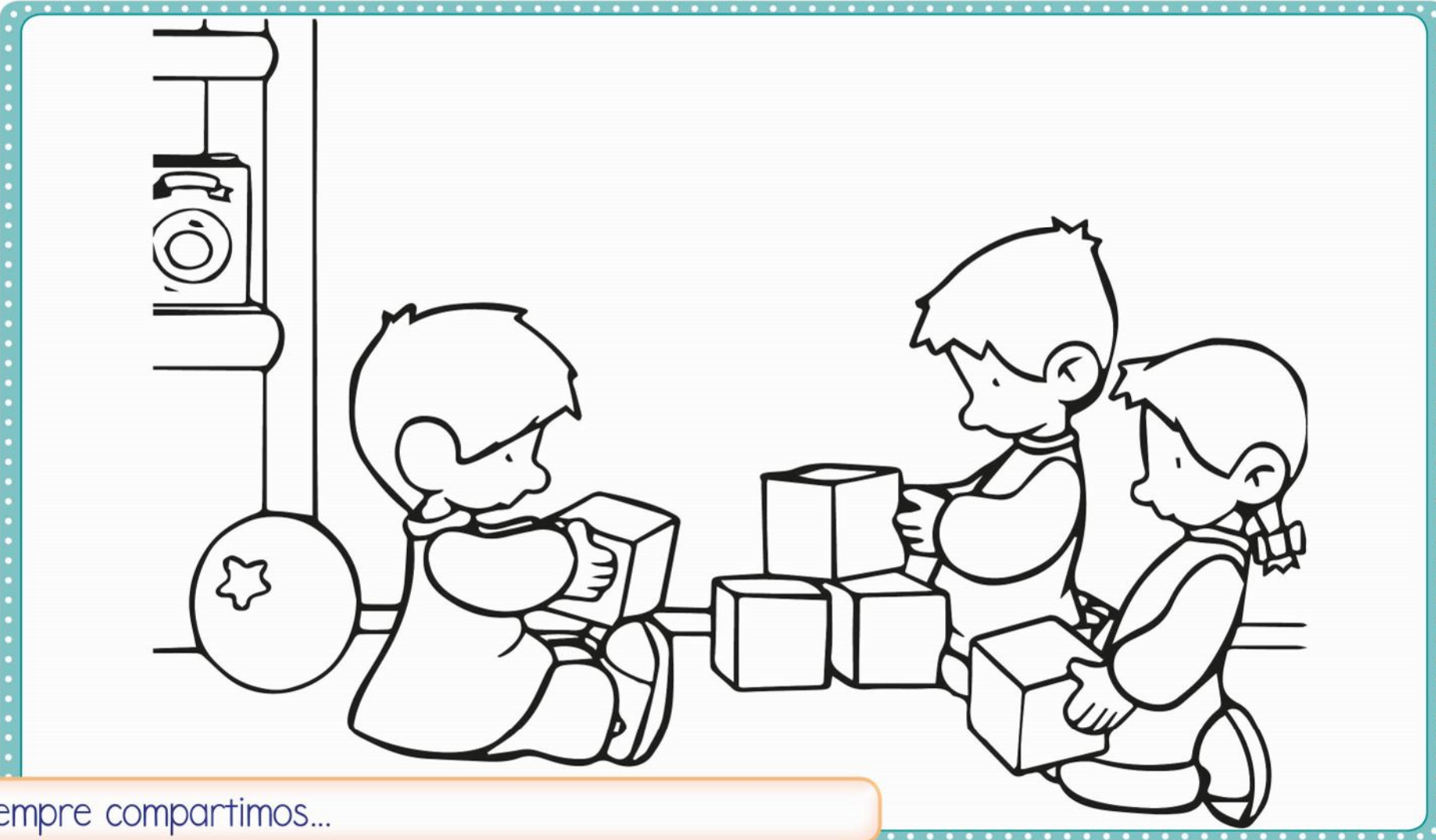

Siempre compartimos...



Mi nombre es: \_\_\_\_\_

--	--	--

❖ Pinta con crayola y encierra los juguetes que faltan guardar, recuerda que después de jugar tienes que guardar.



Y lo más importante es que somos ordenados, por eso vivimos mejor.

Mi nombre es: \_\_\_\_\_



f Guía de Clases JB

# Día de las Américas (14 de abril)

❖ Decora libremente y dialoga sobre esta fecha en la que nos une todas las razas.



Mi nombre es: \_\_\_\_\_



f Guía de Clases JB

# Útiles escolares

❖ Marca con una aspa (X) los útiles escolares que utilizas en el aula.

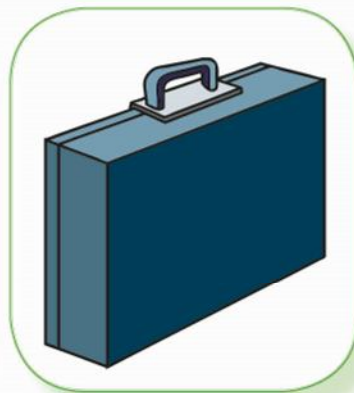
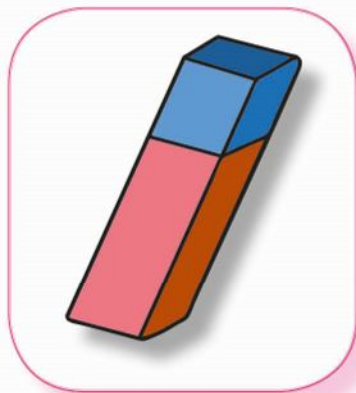
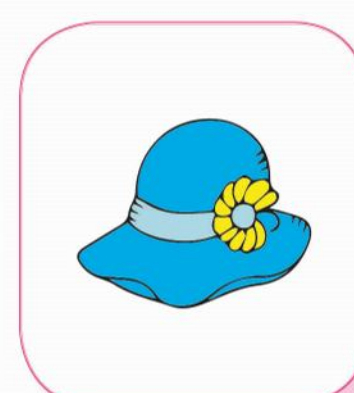



Mi nombre es: \_\_\_\_\_

\_\_\_\_\_

# La casa y sus partes

◆ Observa e identifica cada una de las partes de la casa, luego colorea tu lugar preferido.

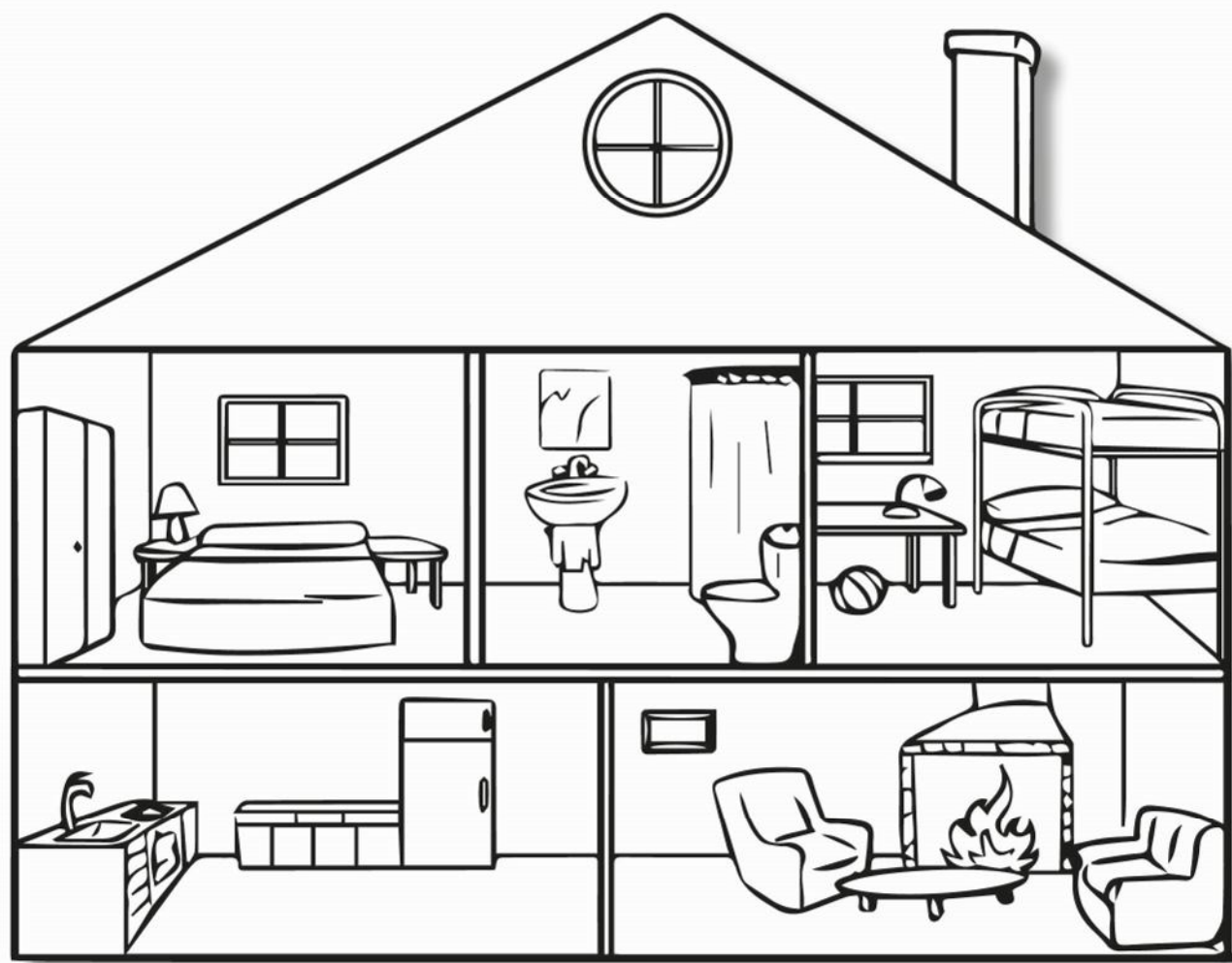



Mi nombre es: \_\_\_\_\_



f Guía de Clases JB

# Ayudando en casa

❖ Pinto y reconozco, como ayudar en casa.

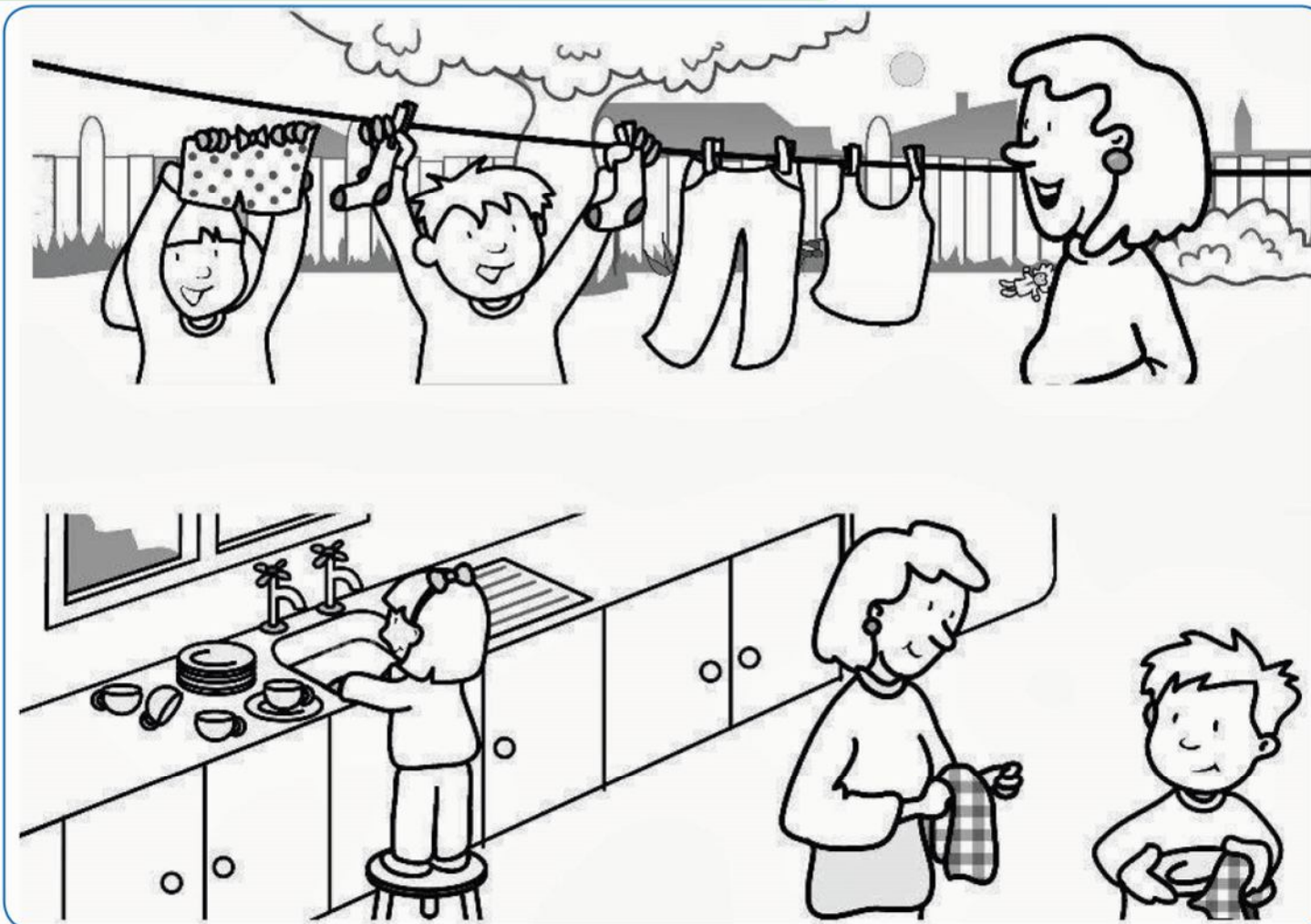

Mi nombre es: \_\_\_\_\_



# Estados de ánimo

❖ Embolilla papel crepé alrededor del estado en que te encuentras.





Mi nombre es: \_\_\_\_\_

--	--	--

# Mi familia

❖ Pega la foto de tu familia.

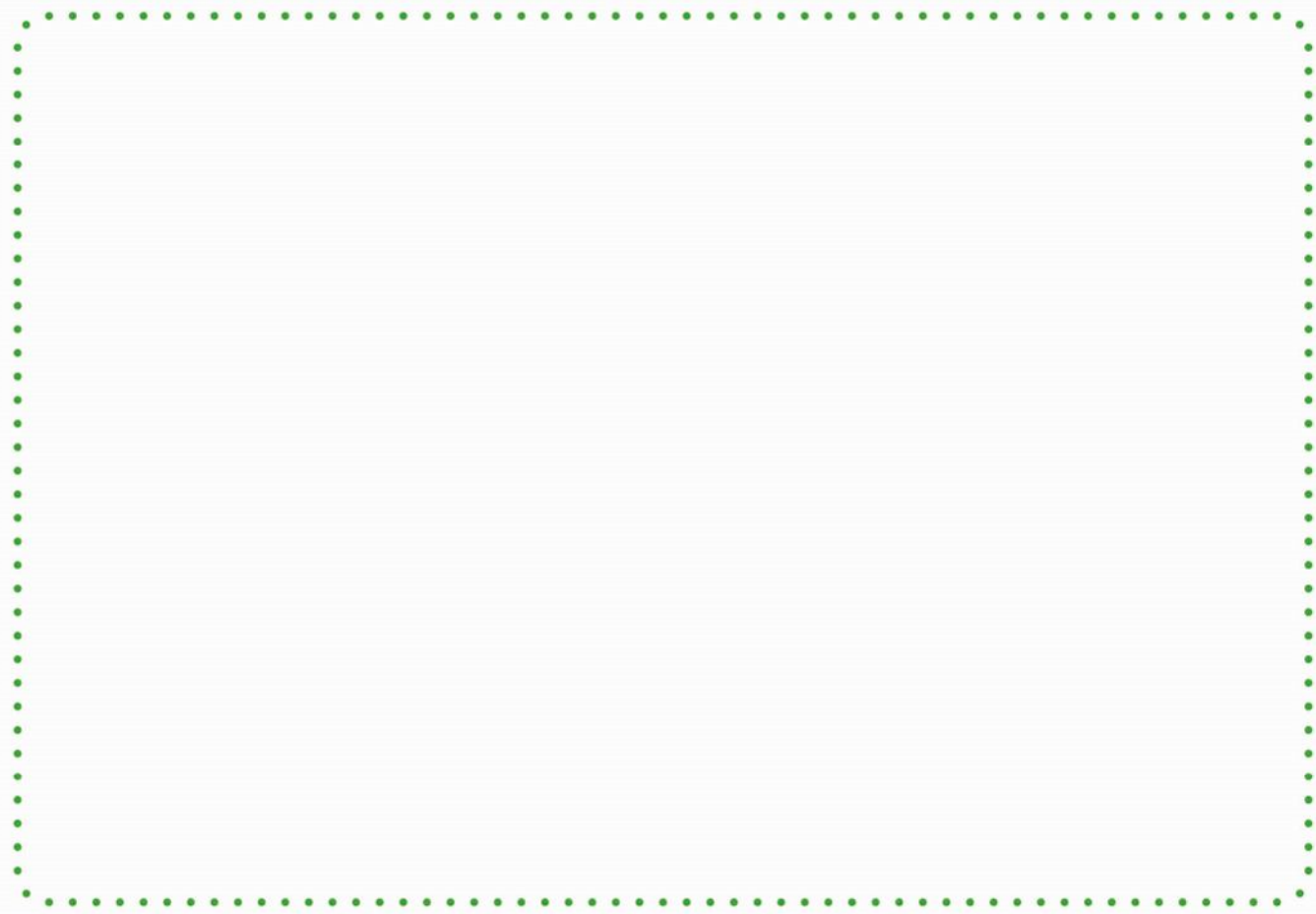



Mi nombre es: \_\_\_\_\_

\_\_\_\_\_

# Miembros de la familia

◆ Decora.



Mi nombre es: \_\_\_\_\_



# Árbol Genealógico

◆ Lleno mi árbol con ayuda de mis fotos familiares.

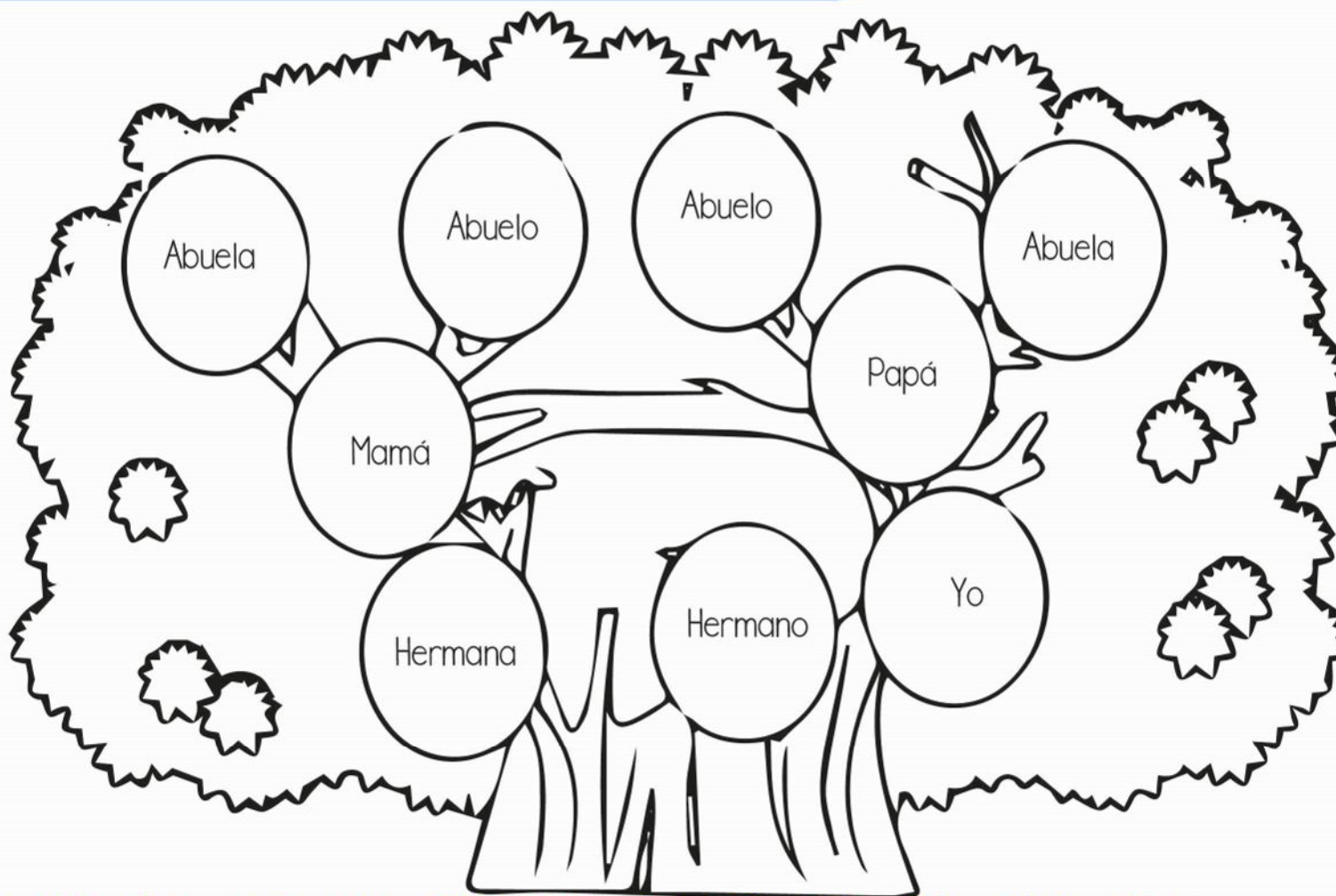



Mi nombre es: \_\_\_\_\_



# Día de la madre (2do domingo de mayo)

◆ Pega la foto de mamá y decora libremente.

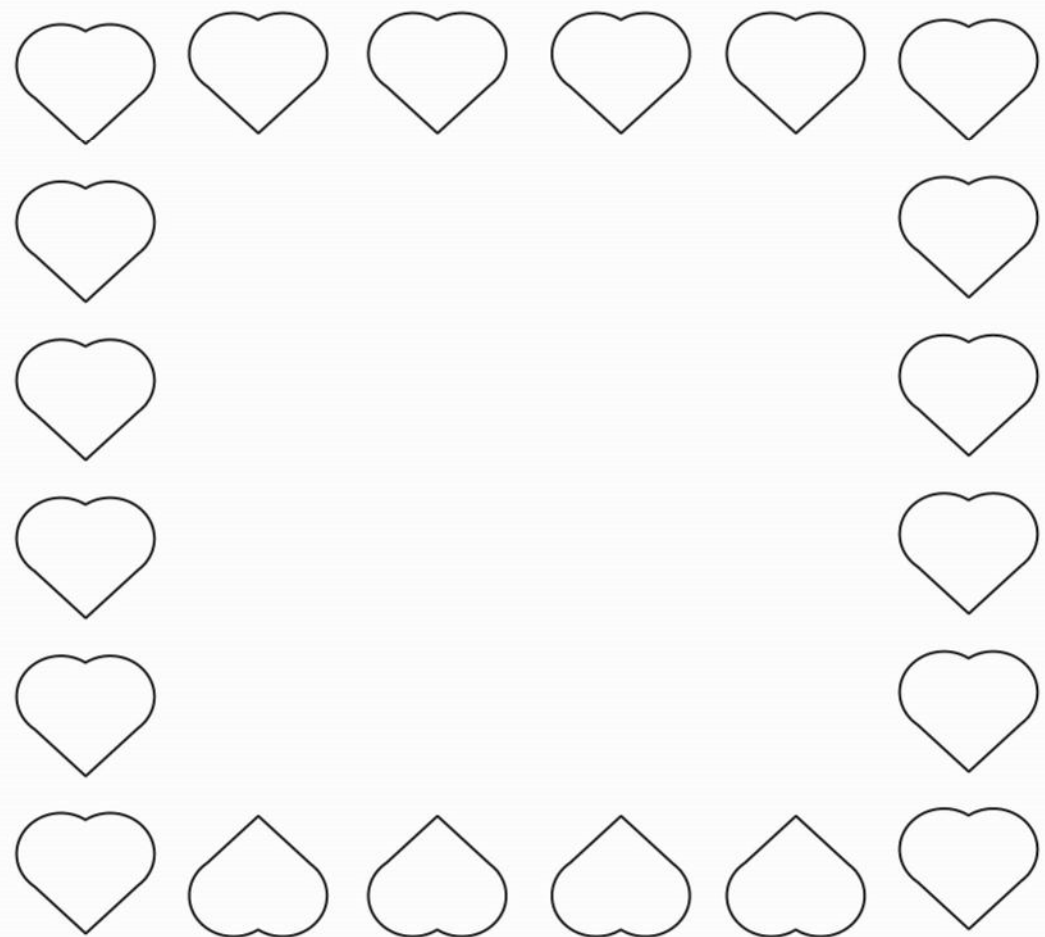

Mi nombre es: \_\_\_\_\_



f Guía de Clases JB

# Día de la educación inicial (25 de mayo)

◆ Decora el marco con la técnica del puntillismo.

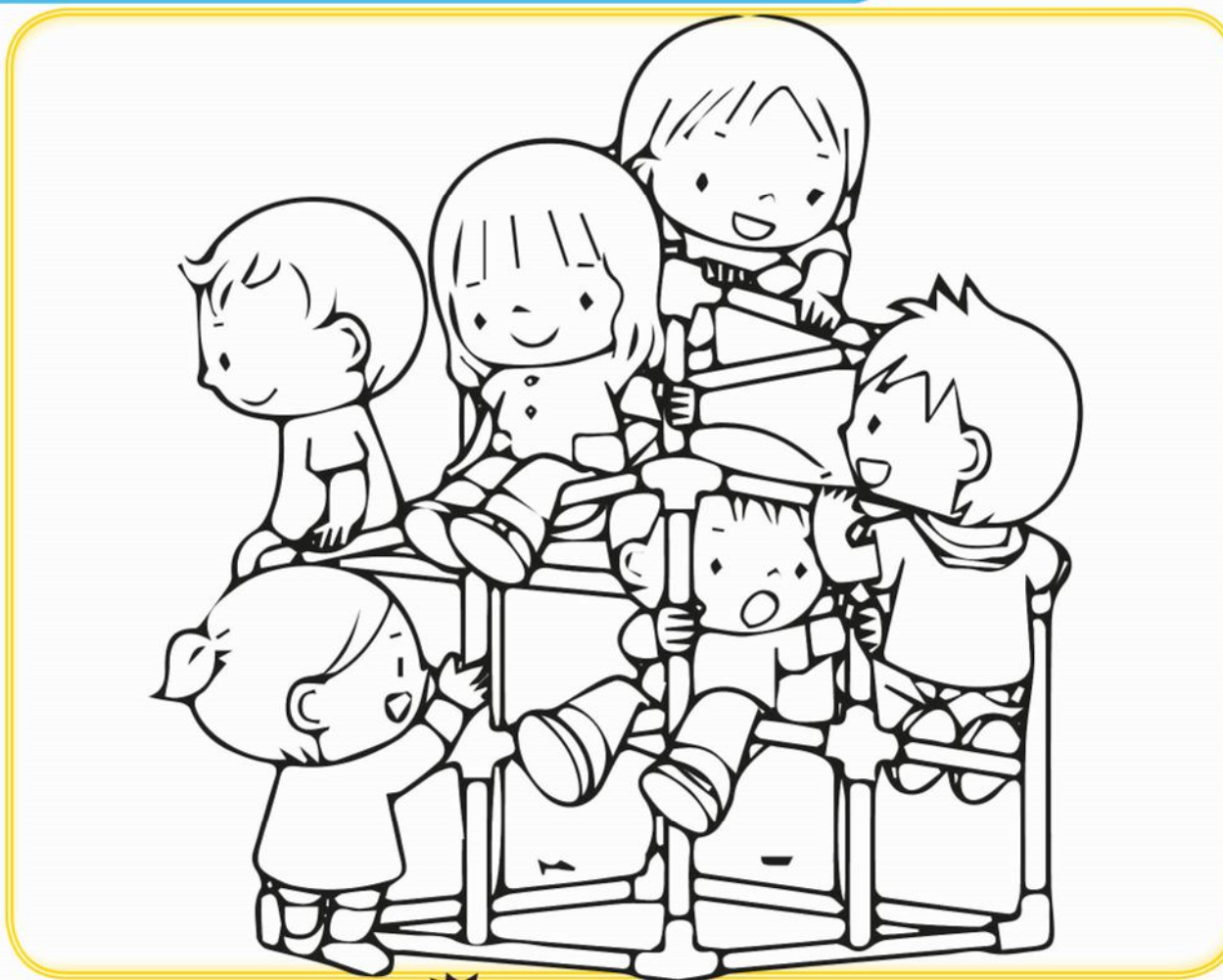

3 años

Descubre... emprende

151

Mi nombre es: \_\_\_\_\_



## Actividad complementaria

### Mi familia en su casita divertida

#### Materiales:

- Bajalenguas
- Foto o dibujo familiar

#### Proceso

- Elaboramos una casita con los bajalenguas y lo pintamos
- Luego pegamos el dibujo que los niños han realizado o la foto que hay antraido
- Desarrollando de esta manera su creatividad y coordinación.





# Ciencia y Ambiente



3  
AÑOS



 Guía de Clases JB



Mi nombre es: \_\_\_\_\_



f Guía de Clases JB

# Mantengamos limpio nuestro ambiente

◆ Raspa y pega papel en la escoba y pega bolitas de plastilina en la silla.



Mi nombre es: \_\_\_\_\_



f Guía de Clases JB

# Conozco mi cuerpo

❖ Pinta la cabeza de **rojo**, el tronco de **amarillo**, brazos y piernas de **azul** del niño que es como tú.

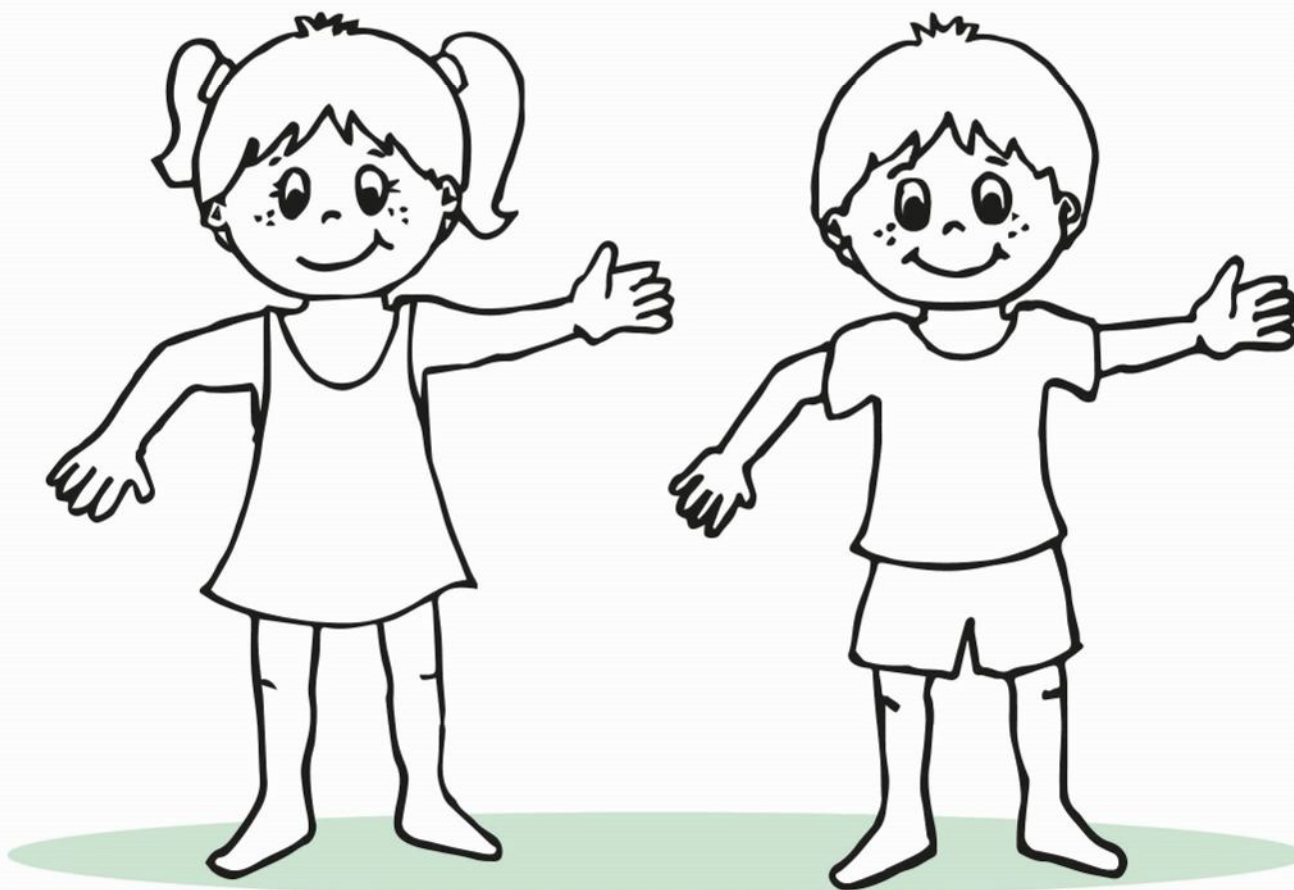

Mi nombre es: \_\_\_\_\_



# Partes de la cara

❖ Recorta y pega las partes de la cara.

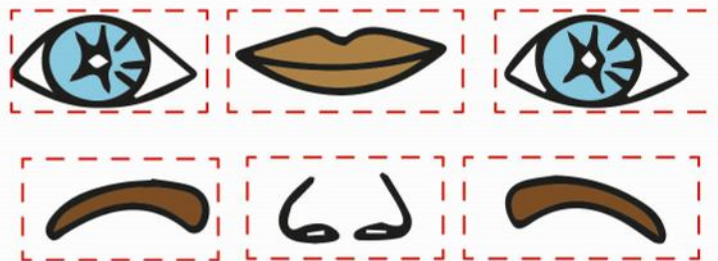
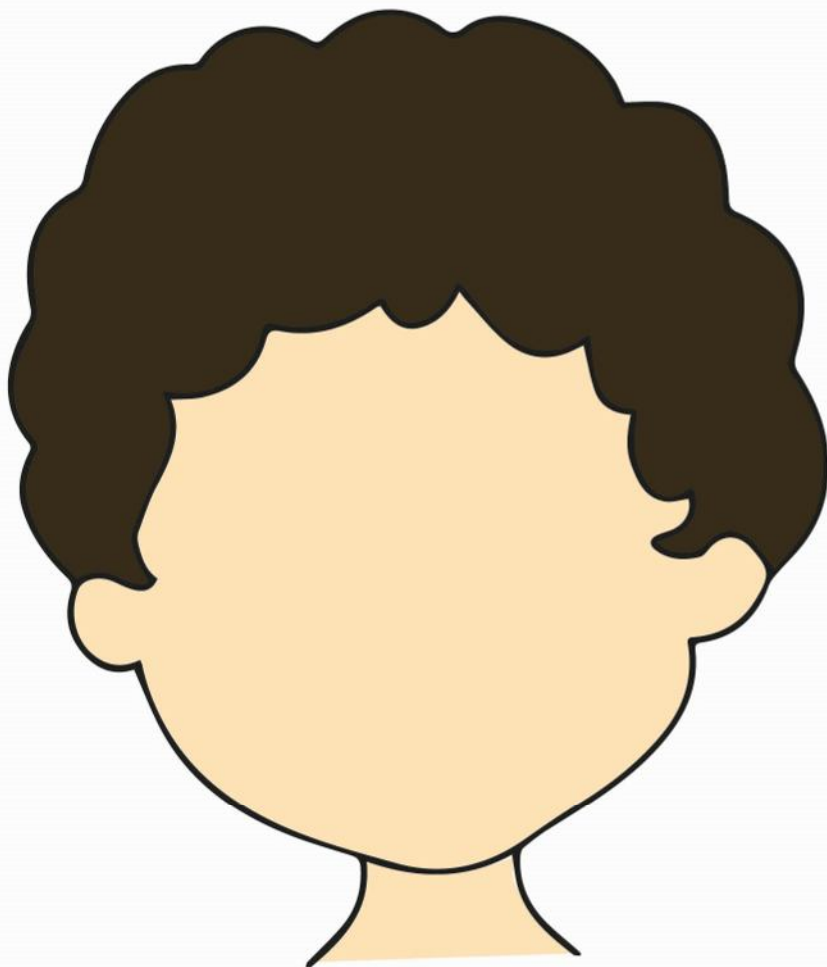

Mi nombre es:

--	--	--



◆ Dibuja las partes de la cara utilizando plumón grueso.

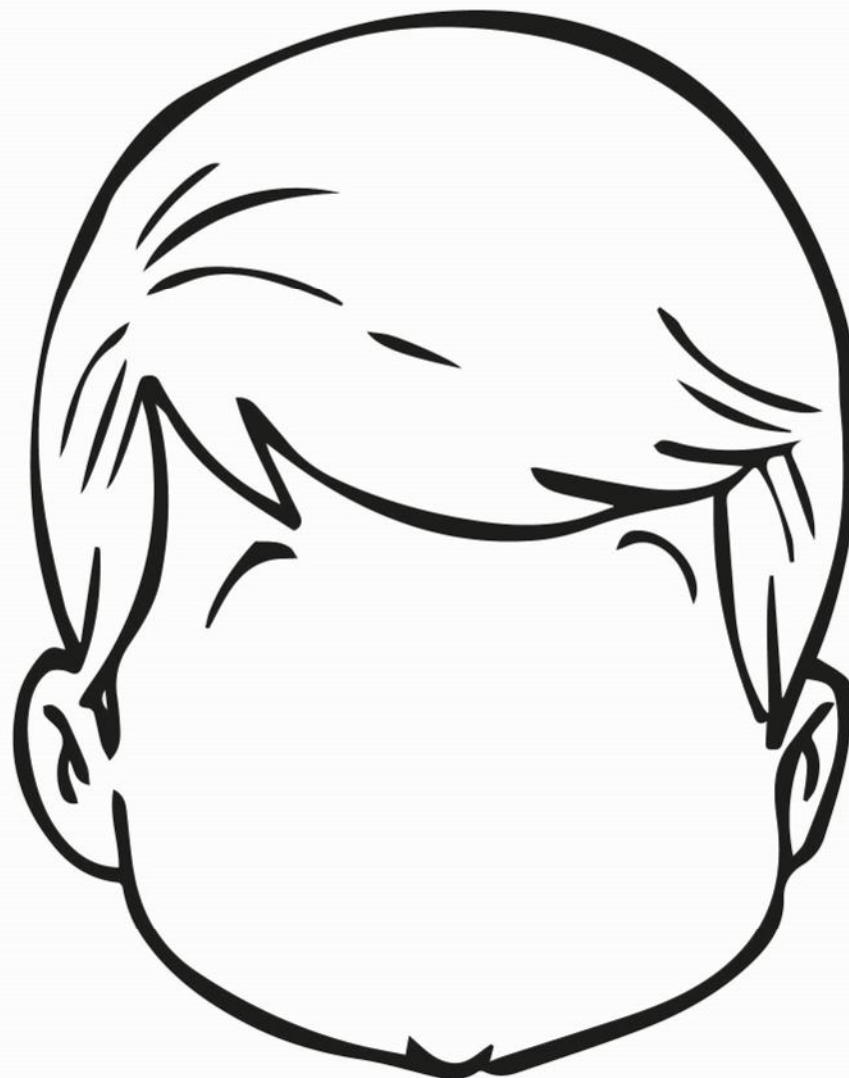

Mi nombre es: \_\_\_\_\_



# El tronco

◆ Pega papel rasgado en el tronco del niño.



Mi nombre es: \_\_\_\_\_



## Extremidades superiores

❖ Dactilopintura: haz huellitas con tempera en el brazo del niño.

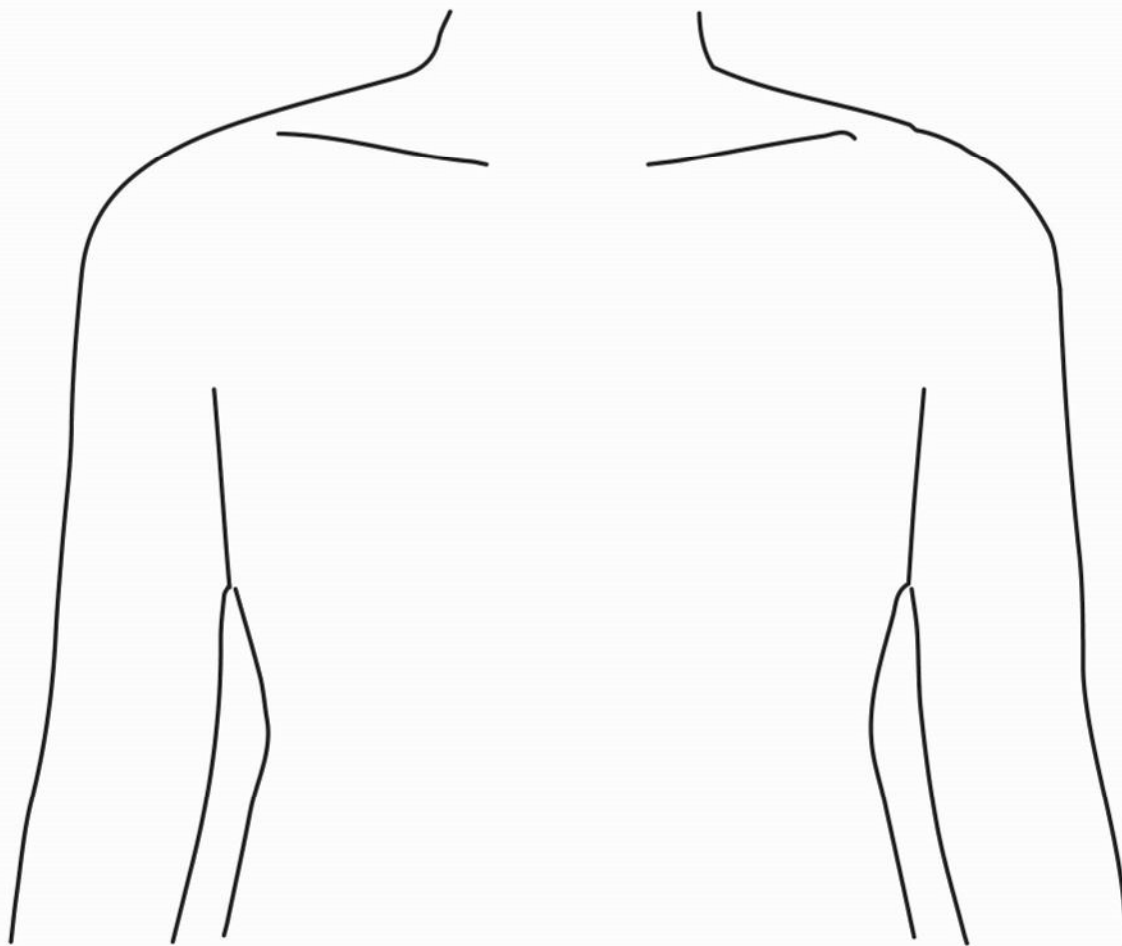

Mi nombre es: \_\_\_\_\_



## Extremidades inferiores

❖ Utilizando tus dedos pulgar e índice, recorta serpentina y pega pedacitos en las piernas.





Mi nombre es: \_\_\_\_\_



# Hábitos de aseo

◆ Colorea los hábitos de aseo personal y practica en casa.

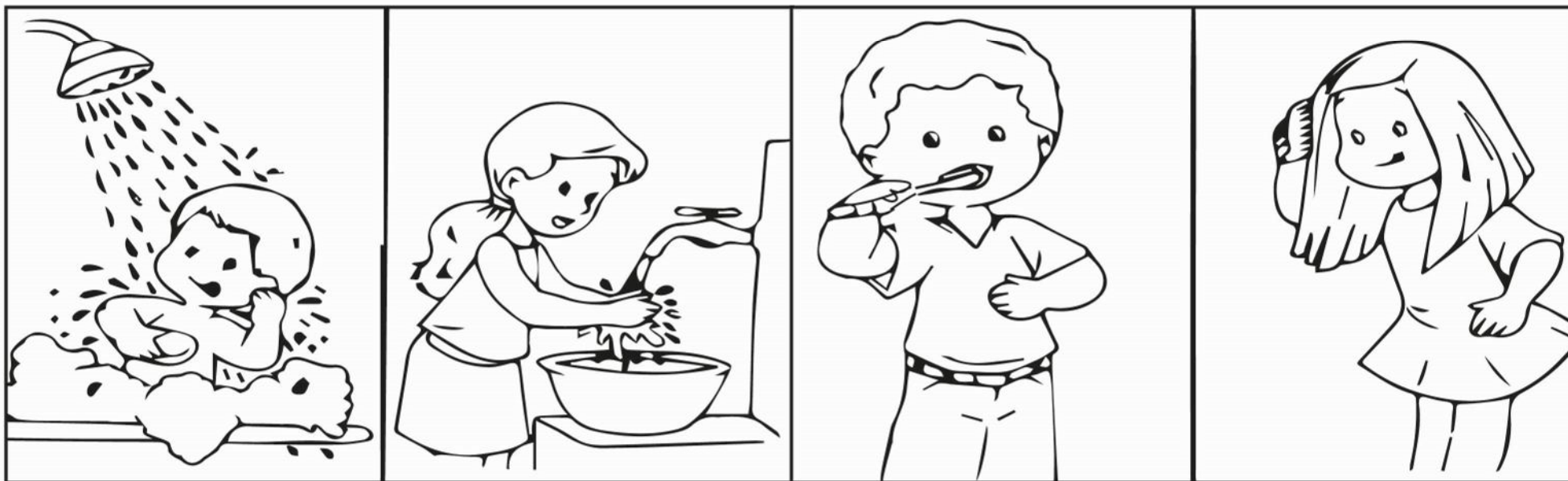

Mi nombre es: \_\_\_\_\_



## Cepillando nuestros dientes

◆ Utiliza las técnica del embolillado y pega en el cepillo.

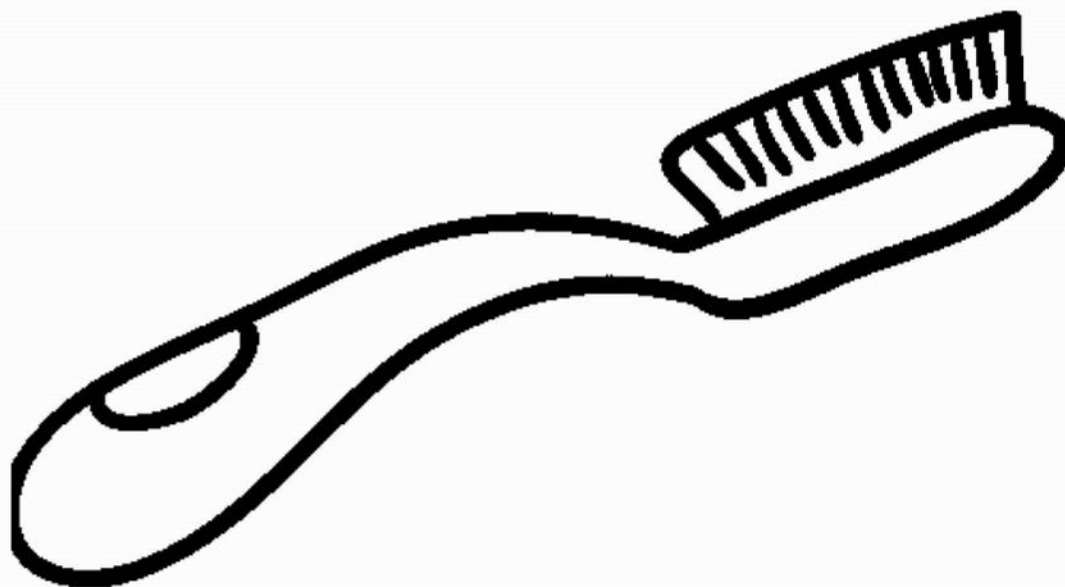

Mi nombre es: \_\_\_\_\_



## Útiles de aseo

- ❖ Pega trozos de tecnopor en el jabón, lana picada en el cepillo y plastilina en la parte dental.





Mi nombre es: \_\_\_\_\_

--	--	--

❖ Relaciona los útiles de aseo con las actividades que realizan los niños. Une con serpentina.

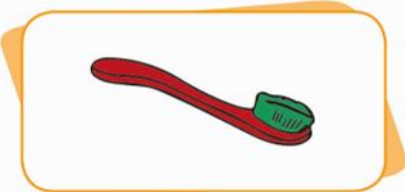
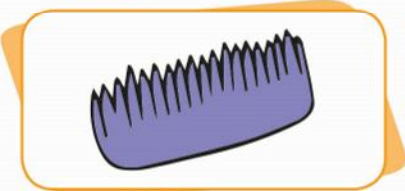

Mi nombre es: \_\_\_\_\_



# Sistema digestivo

❖ Observa, moldea plastilina y pega en el sistema digestivo.

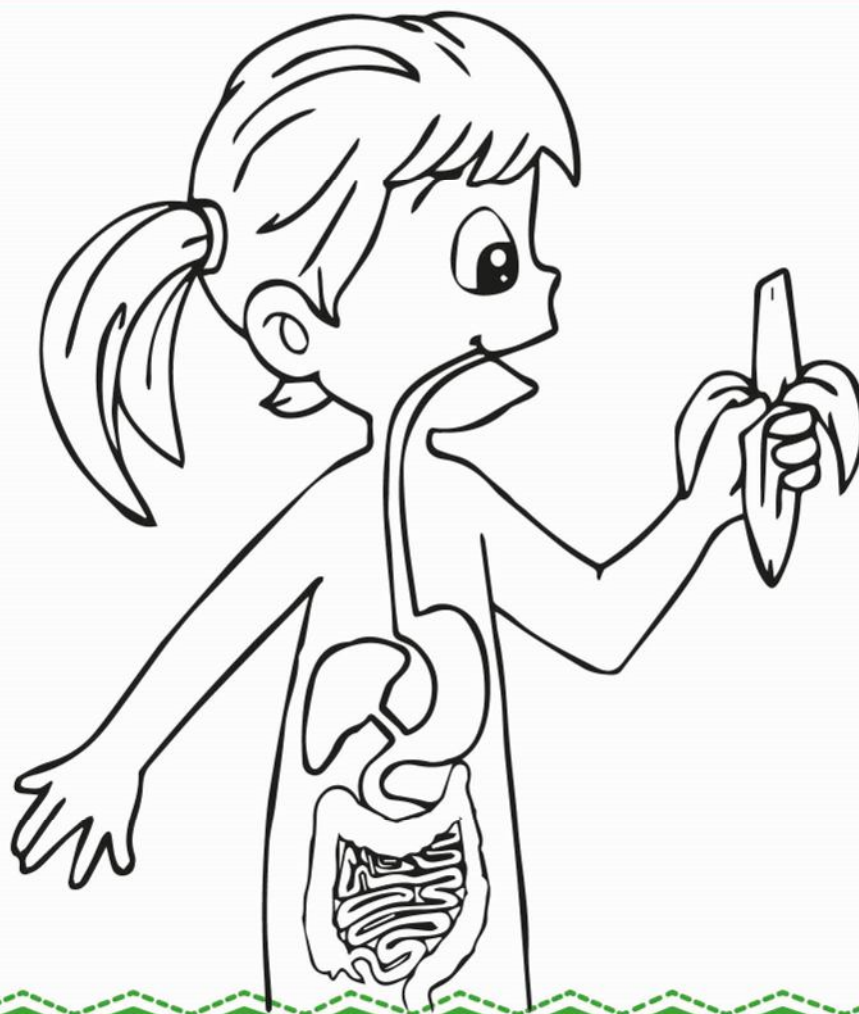

Mi nombre es: \_\_\_\_\_

--	--	--



◆ Rasga y pega papel en el estómago.

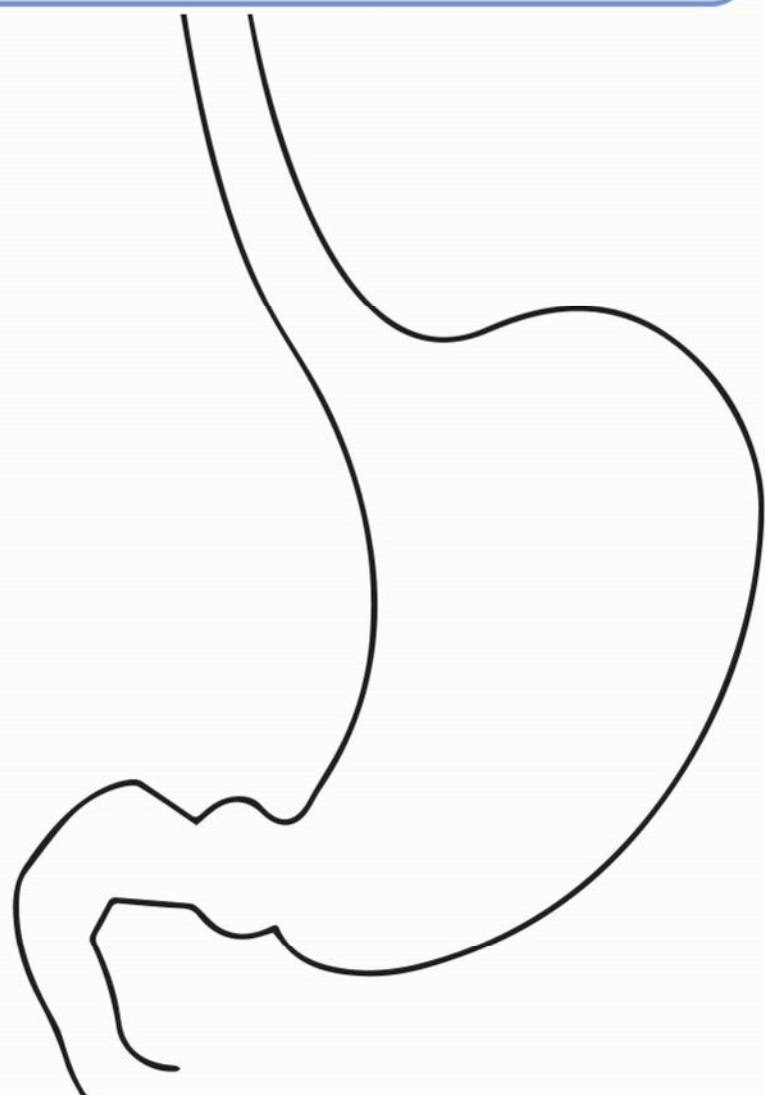

Mi nombre es: \_\_\_\_\_



# Alimentos nutritivos

❖ Colorea los alimentos que te ayudan a crecer.

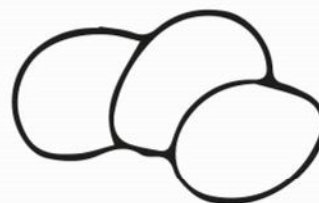
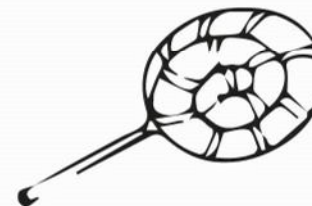

Mi nombre es: \_\_\_\_\_



de Clases JB

❖ Marca (X) los alimentos que no te nutren.

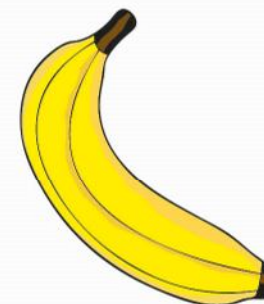
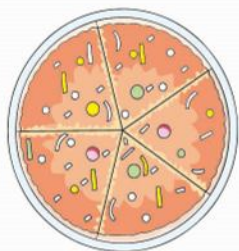



Mi nombre es: \_\_\_\_\_



# Lonchera nutritiva

◆ Recorta las figuras de la pagina 19 y pega los alimentos que te nutren dentro de la lonchera.

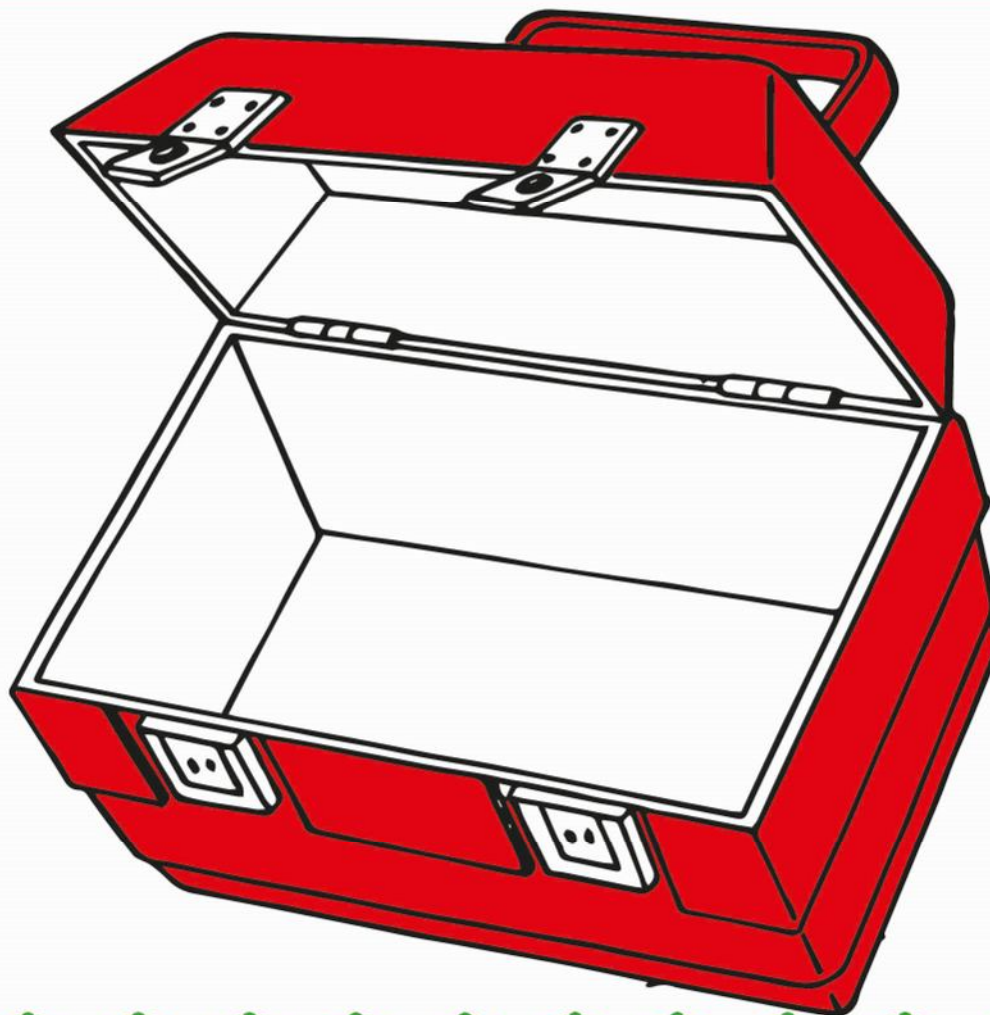

Mi nombre es:

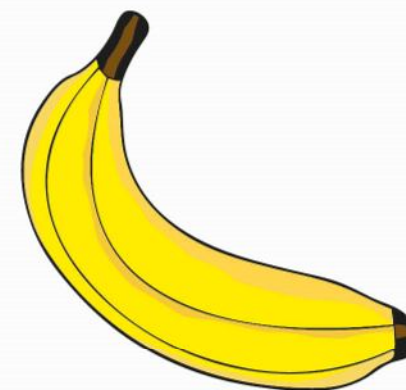
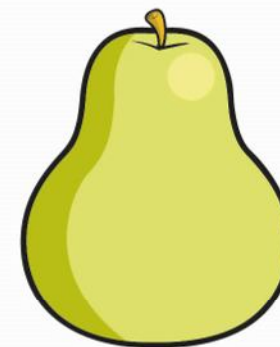

Mi nombre es: \_\_\_\_\_



# Sistema respiratorio

❖ Colorea el recorrido del aire en nuestro cuerpo.

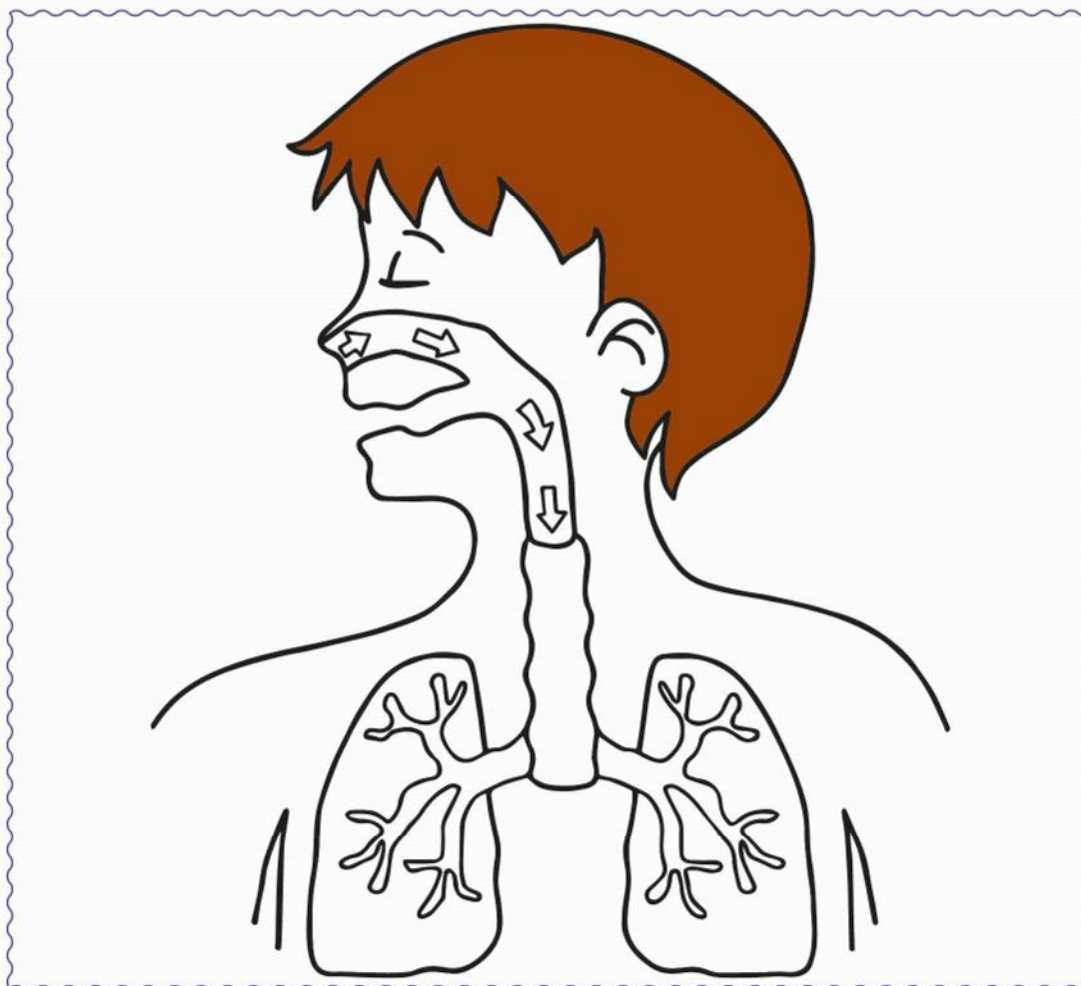

Mi nombre es: \_\_\_\_\_



## Actividad complementaria N° 1

### Conociendo mi cuerpo

#### Finalidad:

- Desarrollar su percepción visual
- Desarrollar su coordinación motora
- Conocer las partes de su cuerpo

#### Materiales:

- Figuras geométricas de cartulina cansón
- Plastilina

#### Procedimiento:

El niño (a) armará el cuerpo humano con los siguientes materiales.



Mi nombre es: \_\_\_\_\_



## Actividad complementaria N° 2

### Sistema respiratorio:

#### Finalidad:

- Practicar ejercicios para mejorar la respiración.
- Vivenciar la propia nariz y manos, y tomar conciencia.

#### Materiales:

- Tu cuerpo
- Colchoneta
- Tempera
- Espejo

#### Procedimiento:

Actividades:

Sentada frente al niño, le preguntas: "¿dónde está la nariz?: ¡Aquí!".

Te la tocas y le pides al niño que haga lo mismo.

Con los dedos la tocas despacito... hace cosquillas (acaricias la nariz del niño)

Ahora vamos a jugar con la nariz:

- Dar pequeñas palmaditas en la nariz, diciendo pín, pín, pín...
- Con los dedos índices tapar los agujeros alternativamente y decir cuac, cuac, cuac...
- Tocar el suelo con la nariz...
- Tocar la mesa con la nariz...
- Colorear con pintura de dedos la nariz, frente a un espejo.





# Religión



Mi nombre es: \_\_\_\_\_

# Aprendemos a comunicarnos con Dios

- ◆ Aprendemos que: rezar es hablar con Dios.
- ◆ Utiliza la técnica del embolillado para decorar el marco, luego con ayuda comunícate con Dios.

Jesús te pido que estés en  
mi boca,  
mis oídos,  
mis ojos,  
mis manos,  
mis pies  
y mi corazón.



Mi nombre es: \_\_\_\_\_

# La oración del Padre Nuestro

◆ Aprendemos la oración del Padre Nuestro y decora el marco.



## Padre Nuestro

que estas en el  (cielo)

Santificado sea tu nombre

Venga a nosotros tu  (reino)

Hágase tu voluntad en la  (Tierra)

como en el  (cielo)

Danos hoy nuestro  (pan) de cada día

Perdona nuestras ofensas como también

nosotros  (perdonamos) a los que nos ofenden

No nos dejes caer en la  (tentación)

y líbranos del mal

**AMÉN**



Mi nombre es:



# Bendición de los alimentos

◆ Aprende la oración y decora el marco.

Señor te damos gracias por  
estos alimentos; Bendice las  
manos que lo prepararon, y  
bendice a mi familia.



Mi nombre es: \_\_\_\_\_



# El Ave María

❖ Con tu dedo índice y tempera roja decora el corazón, luego con ayuda de tu profesora repasa la oración.

## AVE MARÍA

Dios te salve, María, llena de eres de gracia, el señor es contigo. Bendita tú eres, entre todas las mujeres, y bendito es el fruto de tu vientre , Jesús.

Santa María, Madre de Dios, ruega por nosotros pecadores, ahora y en la hora de nuestra muerte Amén.



Mi nombre es:

# Ángel de la guarda

◆ Aprende la oración y decora el ángel de la guarda.

## ÁNGEL DE MI GUARDA

Ángel de mi guarda,  
Dulce compañía;  
No me desampares  
Ni de noche ni de día.  
No me dejes solo  
que me perdería.  
Hasta que amanezca  
en los brazos  
de Jesús, José y María.  
AMÉN.



Amén

Mi nombre es: \_\_\_\_\_

# Semana santa

❖ Colorea libremente la imagen.

No fueron los clavos los que  
sostuvieron  
a Jesús en la cruz. fue el AMOR  
El amor por ti, por mi...!  
Y ese amor tú puedes entregarlo  
a cambio a quien lo necesité...  
A un niño, un anciano, un amigo...  
un humano.

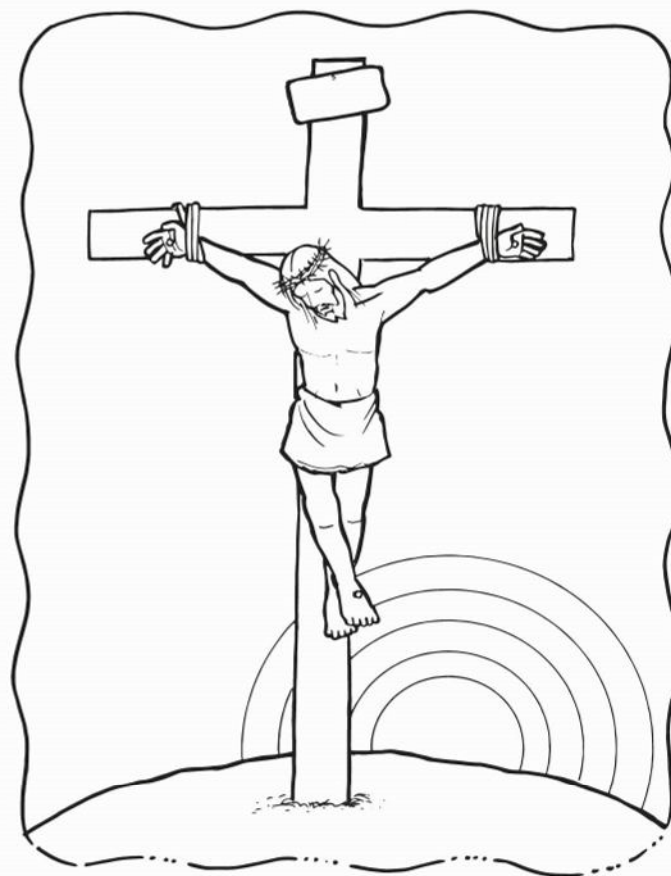

Mi nombre es: \_\_\_\_\_



# La casa de Dios

◆ Decora con escarcha la cruz y colorea.

Jesús nos espera en su casa  
ven conmigo a la casa de  
Dios.



Mi nombre es: \_\_\_\_\_



# Jesús y su familia

◆ Aprendemos... quiénes forman la sagrada familia y colorea.



Mi nombre es: \_\_\_\_\_

# María, tu eres nuestra madre

◆ Escuchamos la historia de la Virgen María. (Colorea)

María madre  
de Jesús  
y de todos  
los niños.



Mi nombre es: \_\_\_\_\_

# Historia de la Virgen María

En cova de Iria cerca de Fátima (Portugal), la Virgen María se aparece a tres pastorcitos, Lucía, Jacinta, y Francisco.

La primera aparición sucedió el 13 de mayo de 1917. Se les apareció sobre una encina prometiendole hacerlo siempre allí cada día 13 de los meses siguientes, hasta octubre. Les pide que recen por la paz en el Mundo.

En todas las apariciones la virgen solicita a los pastorcitos el rezo del rosario y la reparación de los pecados cometidos contra Dios y contra el inmaculado Corazón de María.

En la última aparición el 13 de octubre de 1917, se confirma de un modo milagroso que las apariciones tenían el sello de Dios, ese día el sol giraba rápidamente y por tres veces descendió hasta la altura del horizonte, amenazando con caer sobre la tierra.

El horizonte tenía un color púrpura para pasar luego a un color amarillo de fuego. El espectáculo duro un cuarto de hora. La multitud que asistía, invocaba la misericordia de Dios y pedía por la conversión de los pecadores.





Mi nombre es:



# Dios nuestro padre nos ama y cuida siempre

◆ Con ayuda lee y repite este versículo: “Todavía no había nacido yo, cuando tu dios ya me cuidabas”.

**Pega tu foto**

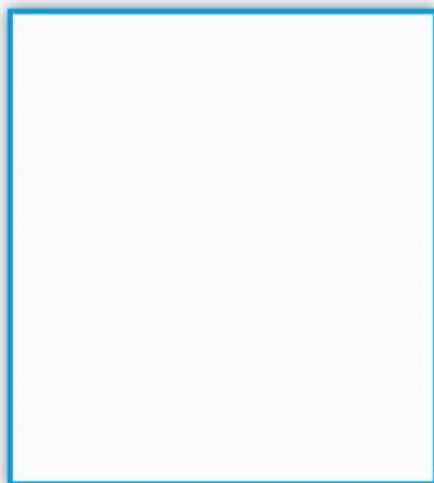

Jesús dijo: Dejad que los niños se acerquen a MI.



DIOS  
ME AMA



Mi nombre es: \_\_\_\_\_

# El valor

❖ Pinta las imágenes con tiza mojada.

Amamos a dios cuando



Ayudamos a los que nos necesitan.



Amamos y respetamos a nuestros amigos.



Amamos y obedecemos a papá y mamá