

# MI CUADERNILLO DE REPASO

4 AÑOS



Nombre: \_\_\_\_\_



Clase: \_\_\_\_\_

Vocales • Números • Cantidades • Tamaños • Colores • Formas



1

# La vocal A



1. Repasa la vocal.

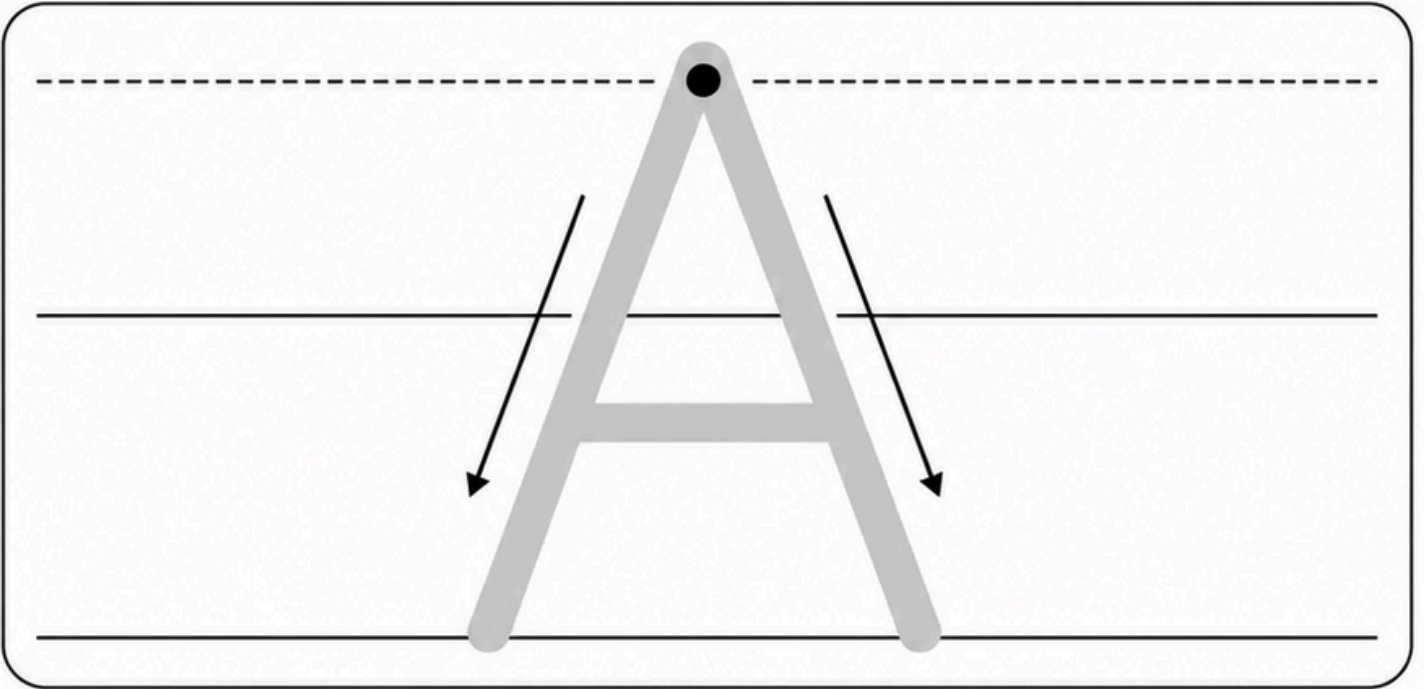

2. Rodea la A.



3. Colorea los dibujos que empiezan por a.

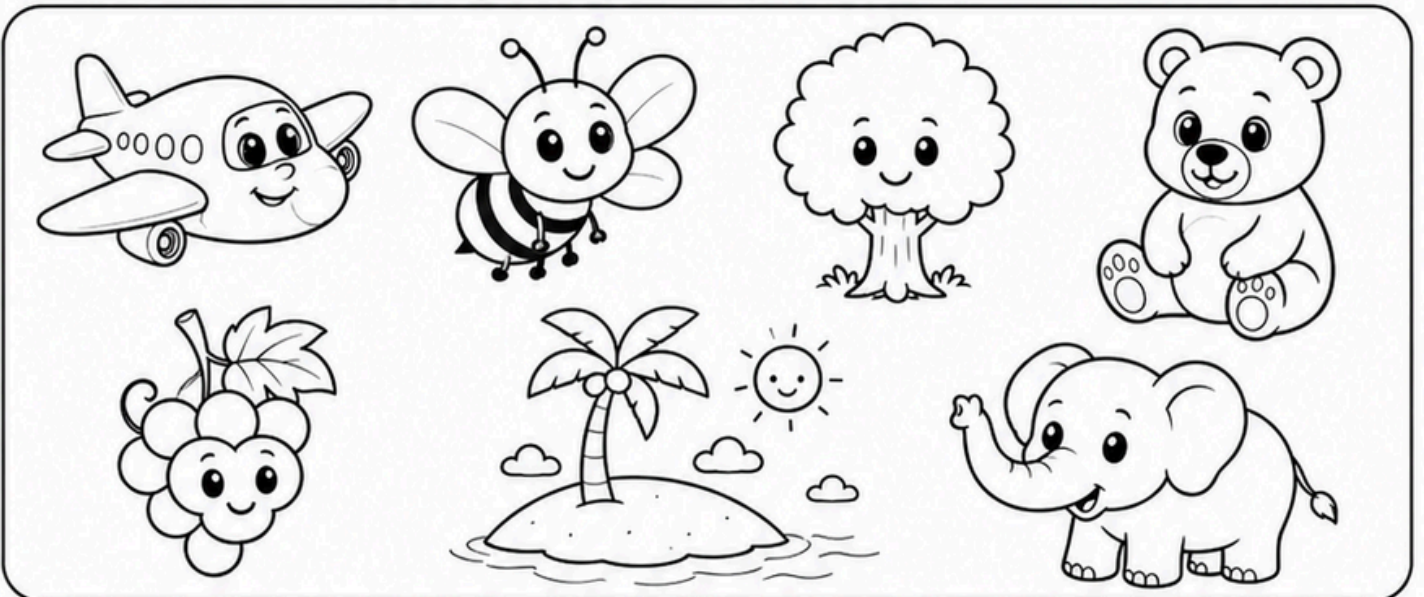

2

# La vocal E



1. Repasa la vocal.

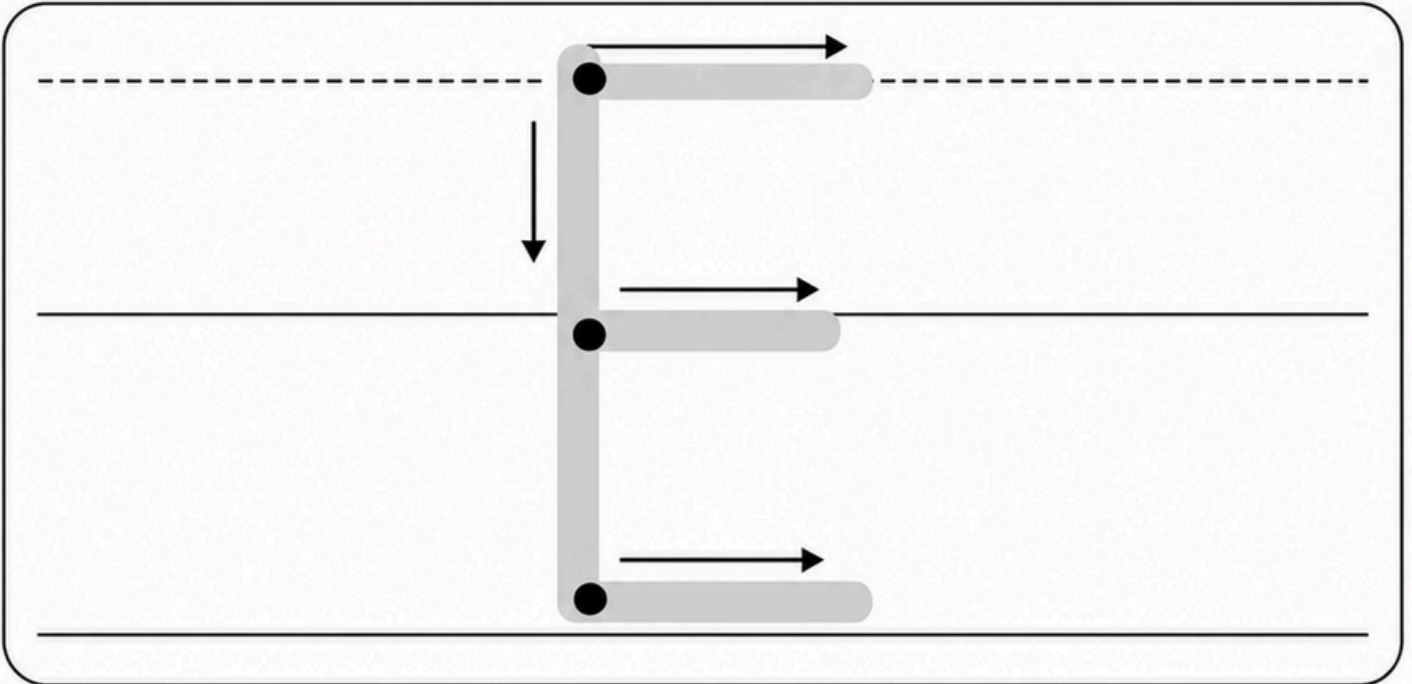

2. Rodea la E.

A E I O E U E A I E

3. Colorea los dibujos que empiezan por e.

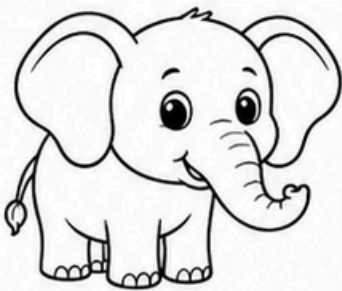

3

# La vocal I



1. Repasa la vocal.

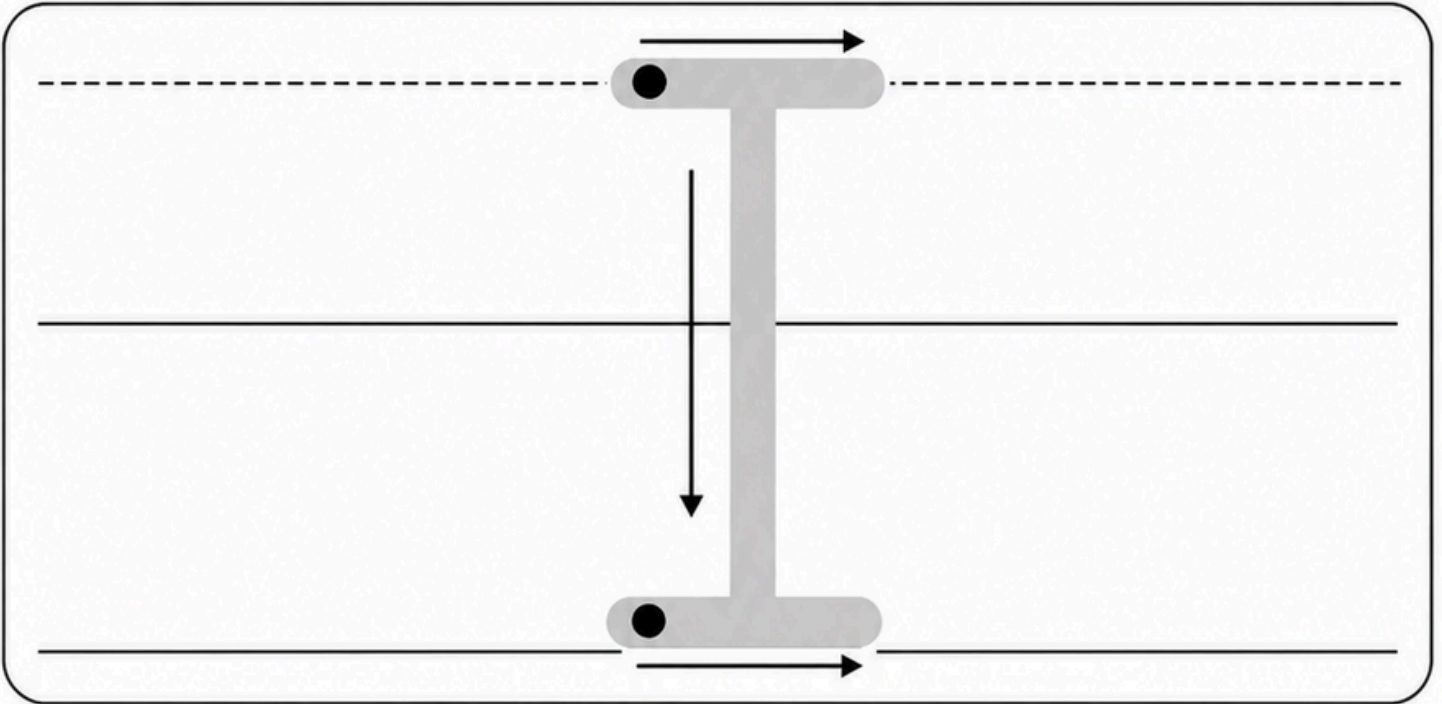

2. Rodea la I.

A I E O U I A E I O

3. Colorea los dibujos que empiezan por i.

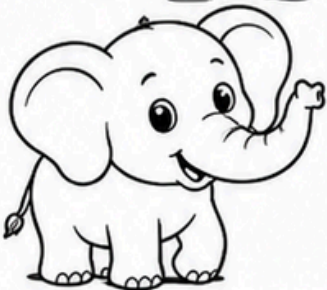
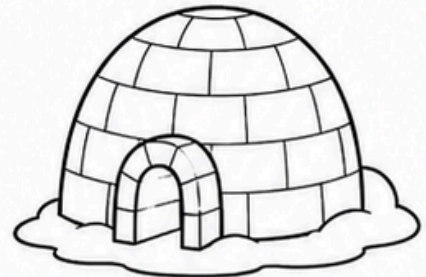
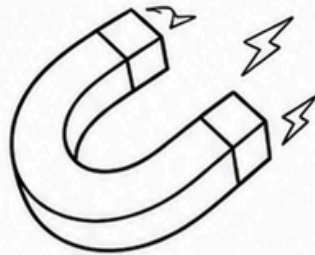
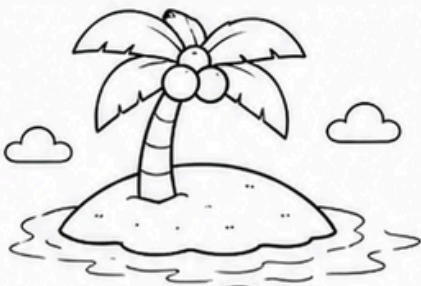

4

# La vocal O



1. Repasa la vocal.

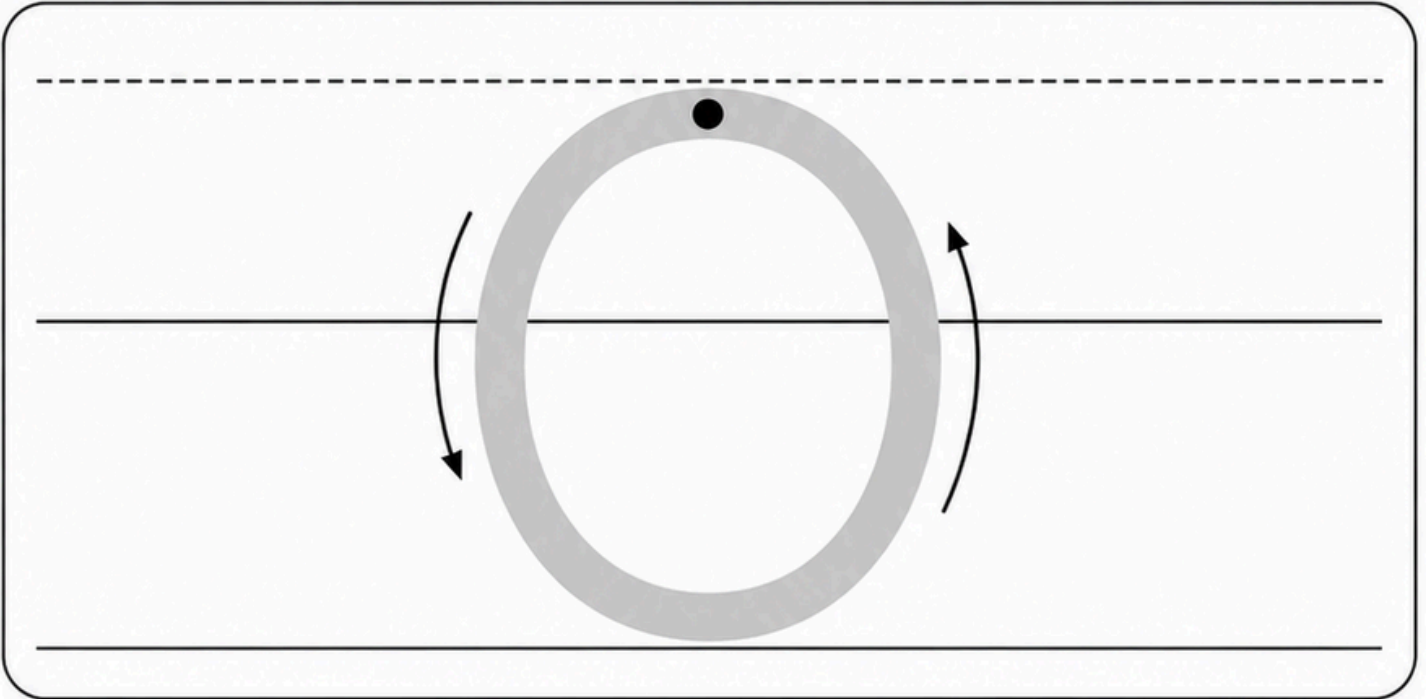

2. Rodea la O.

A E O I U O A O E I

3. Colorea los dibujos que empiezan por o.

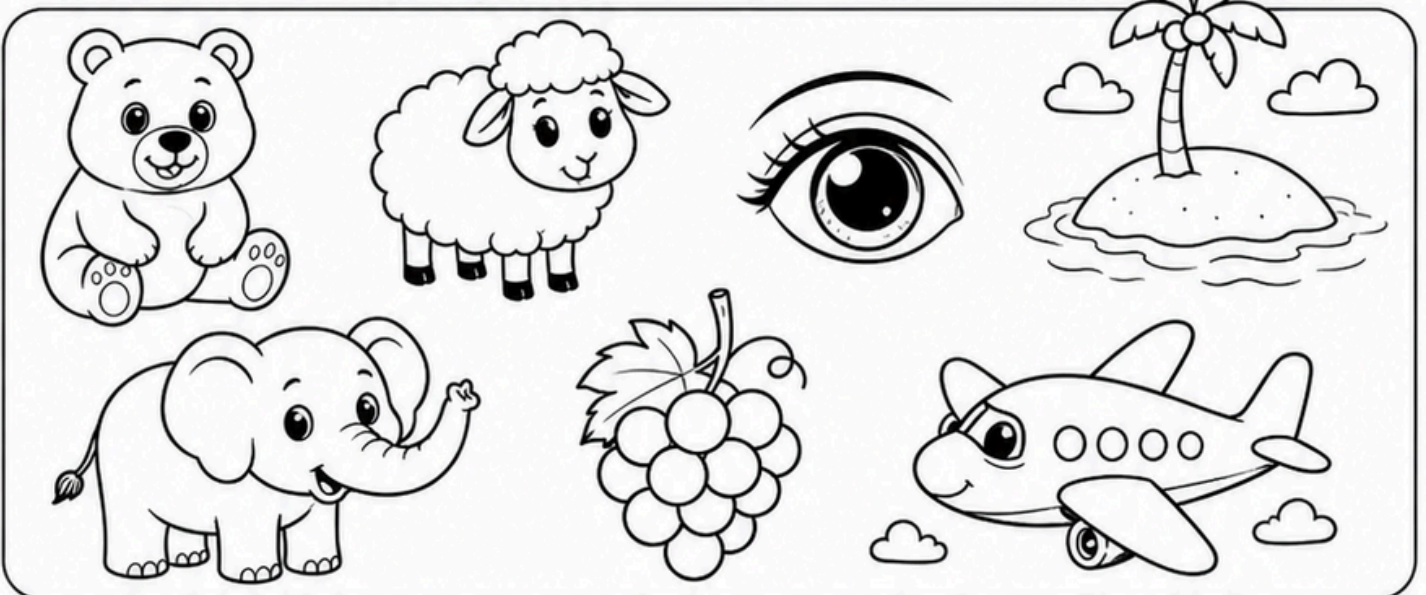

5

# La vocal U



1. Repasa la vocal.

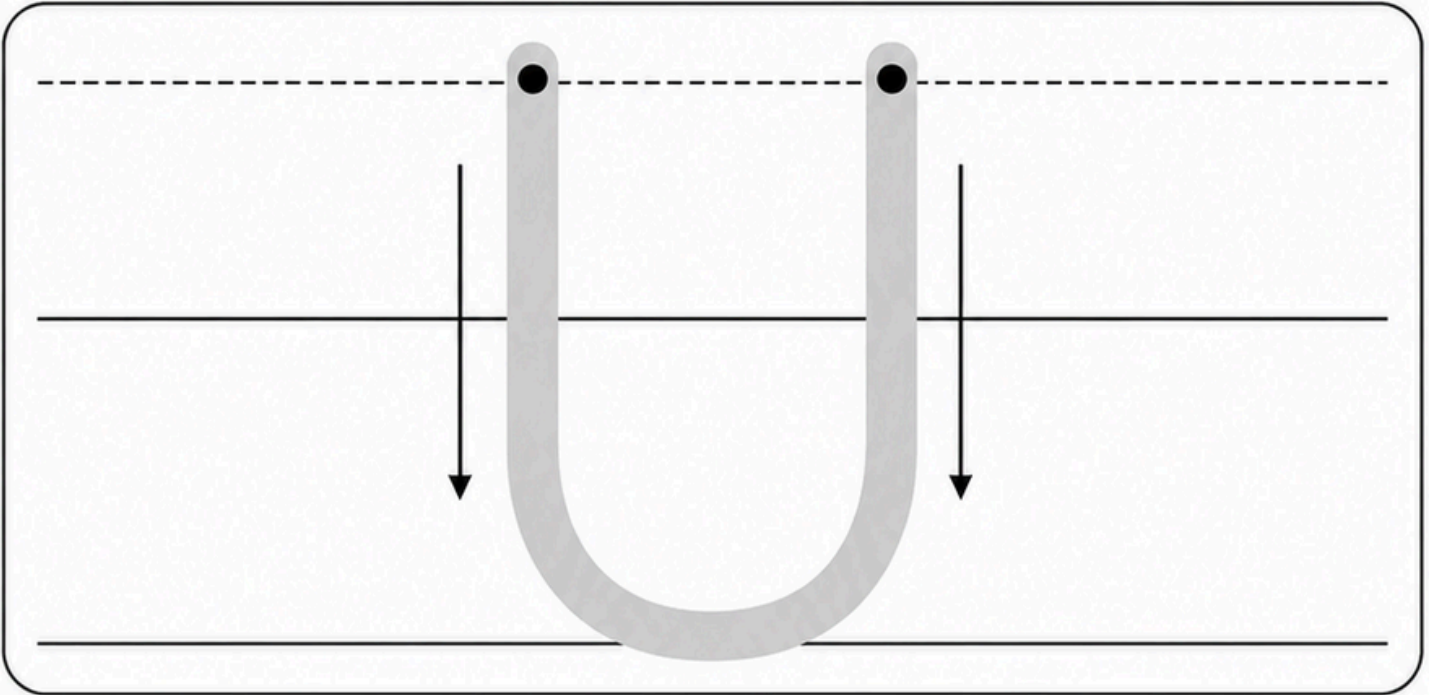

2. Rodea la U.



3. Colorea los dibujos que empiezan por u.

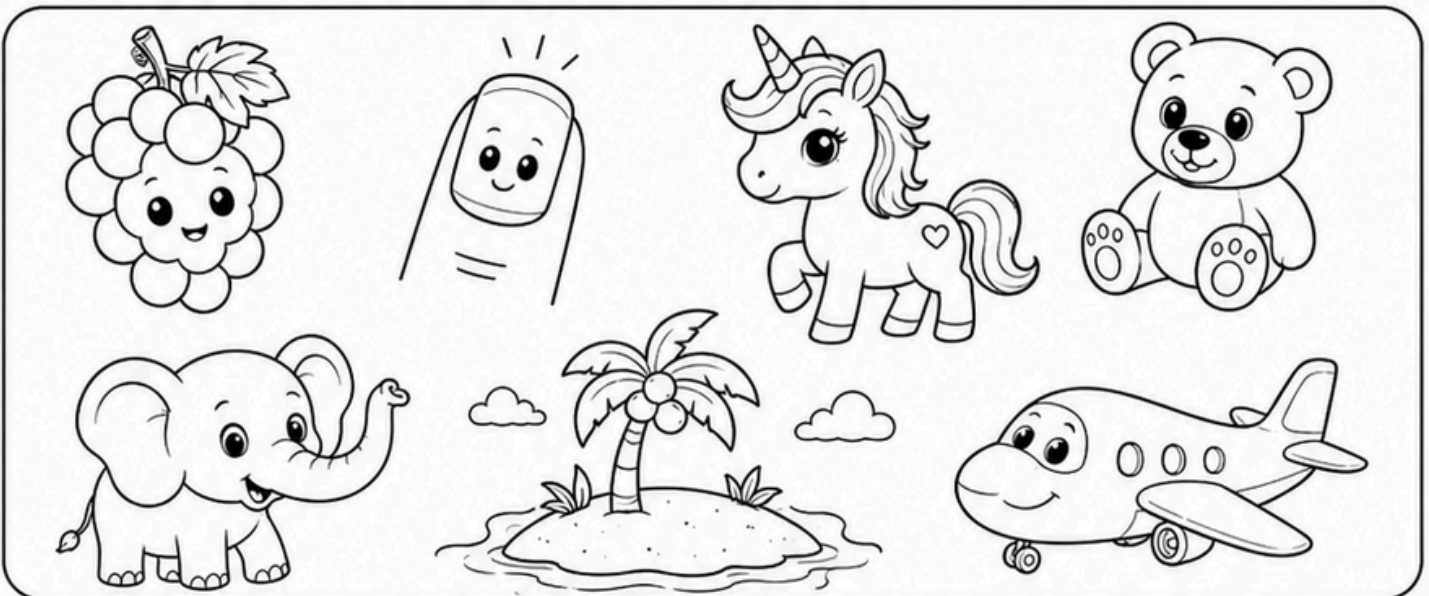

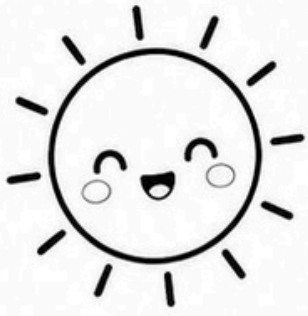

# TRAZO DEL NÚMERO 1



# UNO

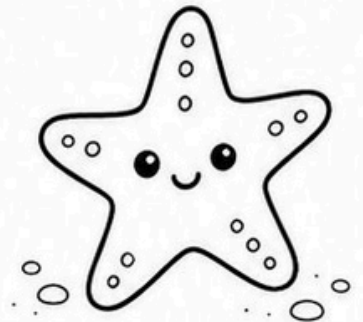
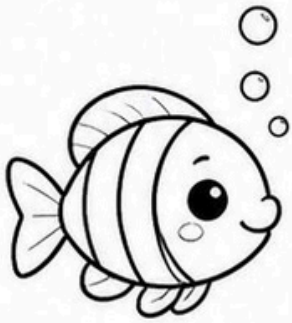
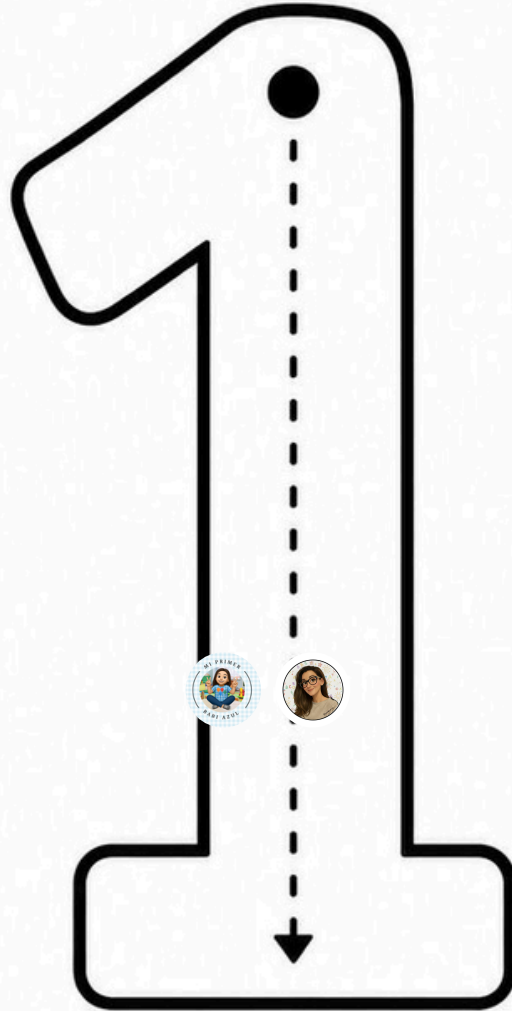

Repasa el número 1.

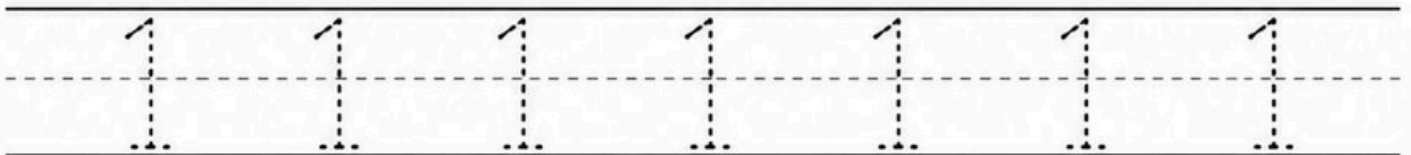
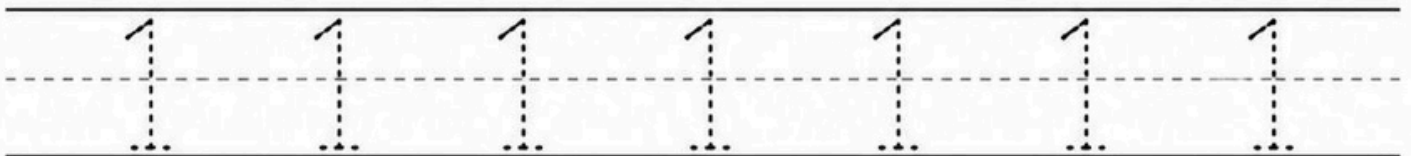
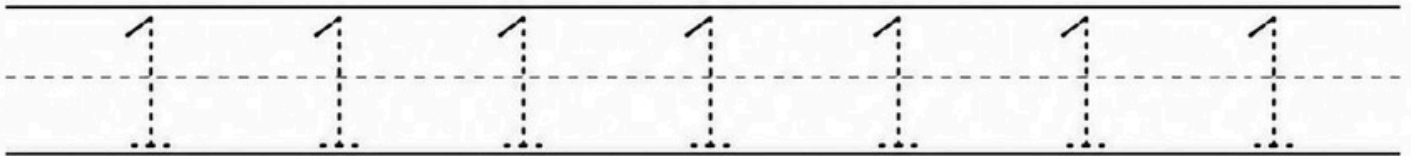

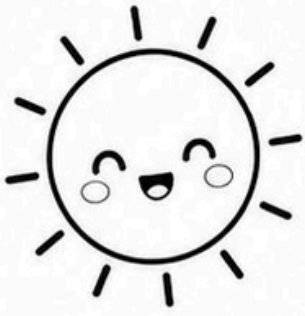

# TRAZO DEL NÚMERO 2



# DOS

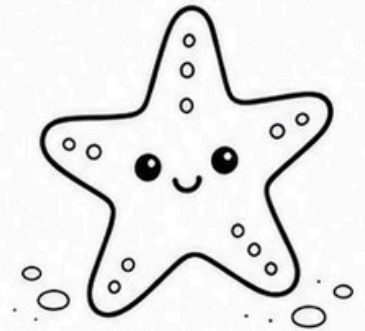
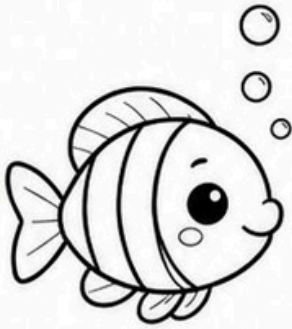
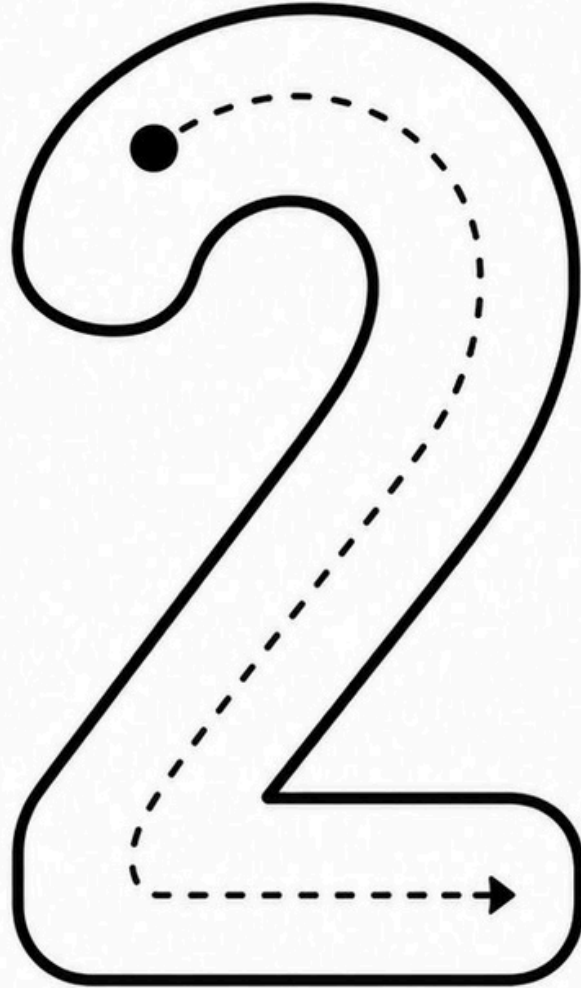

Repasa el número 2.

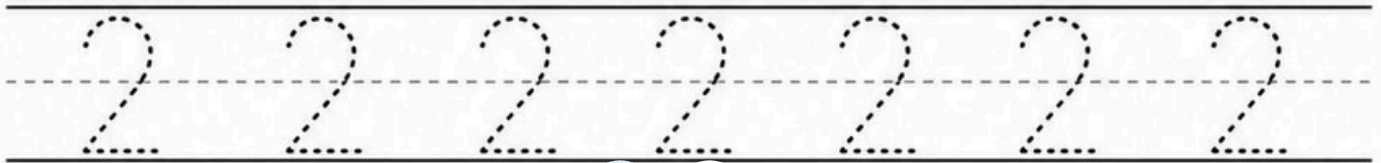
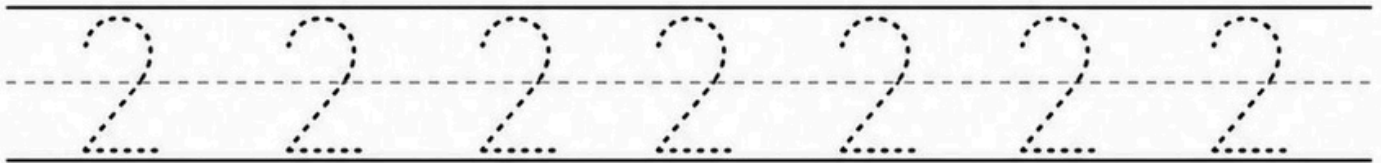
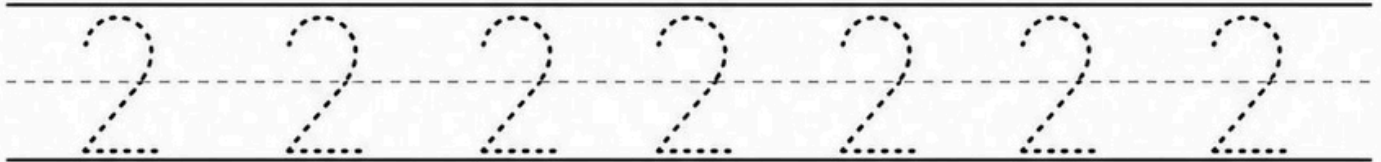

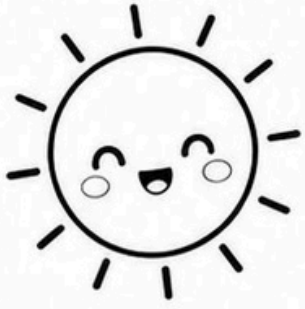

TRAZO DEL NÚMERO 3



TRES

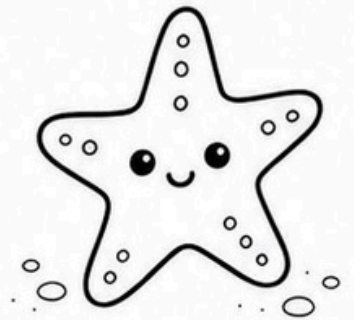
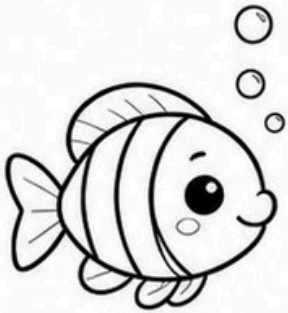
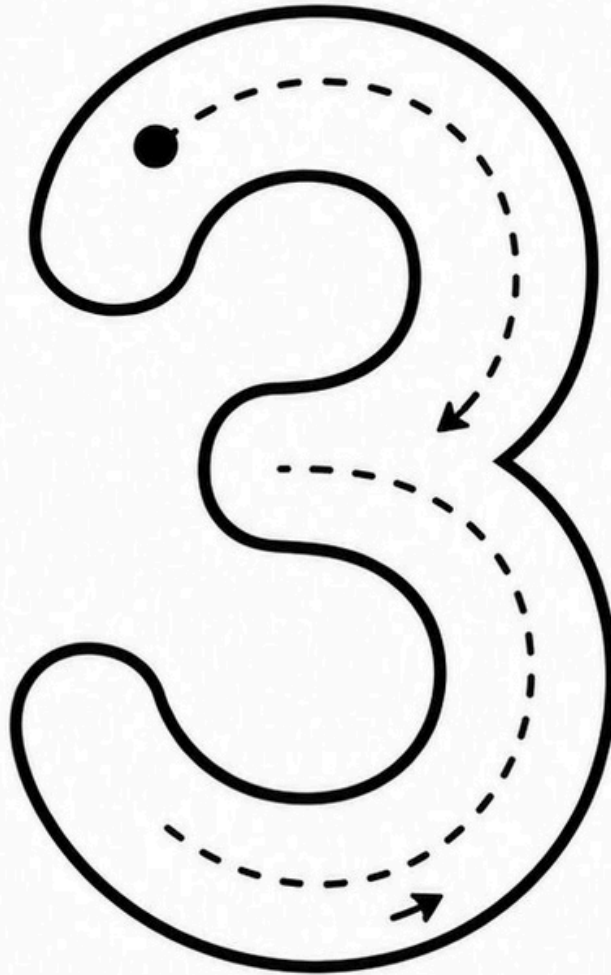

Repasa el número 3.

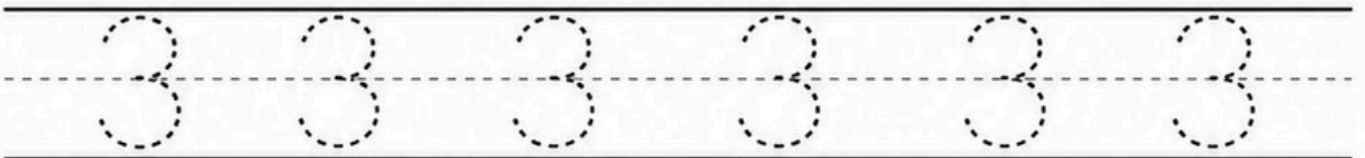
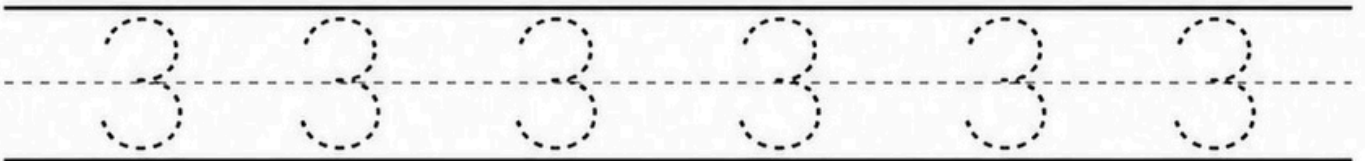
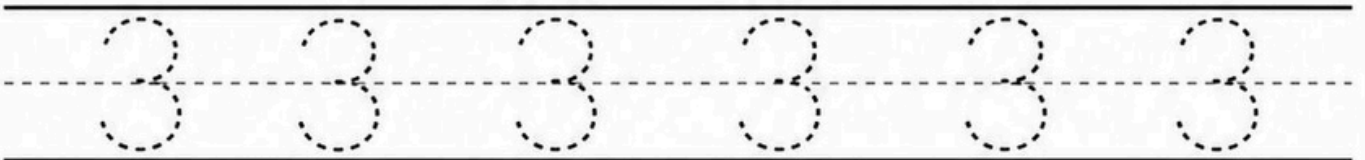



TRAZO DEL NÚMERO 4



CUATRO

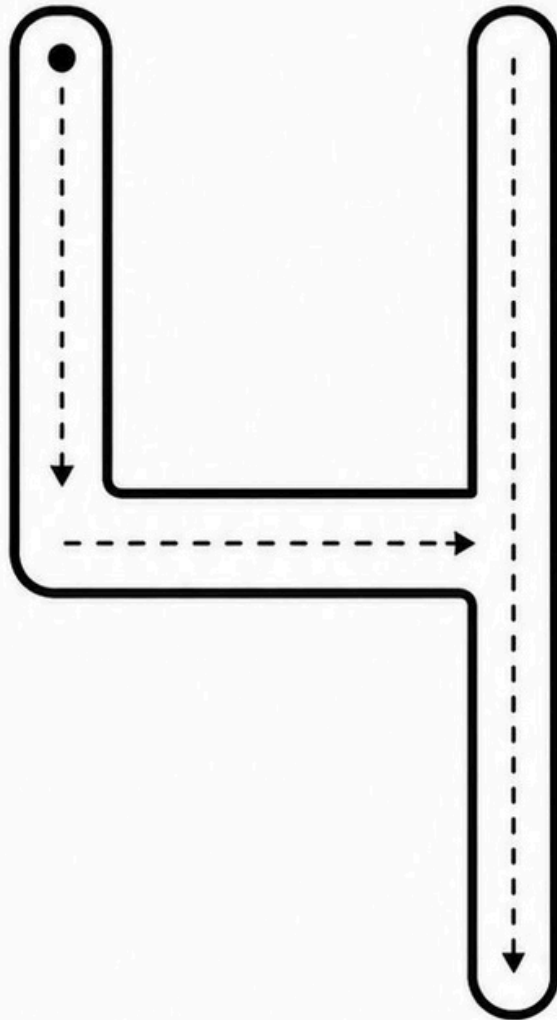

Repasa el número 4.

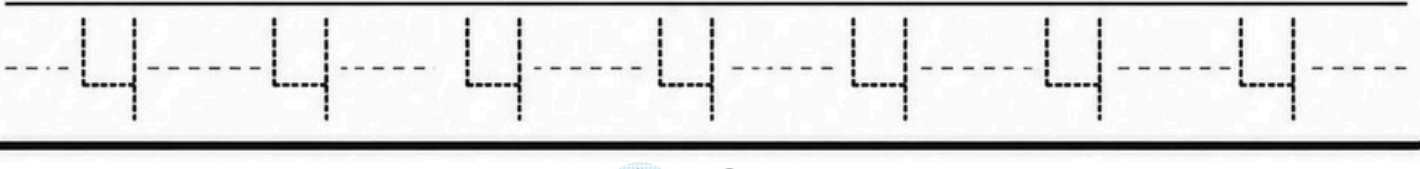
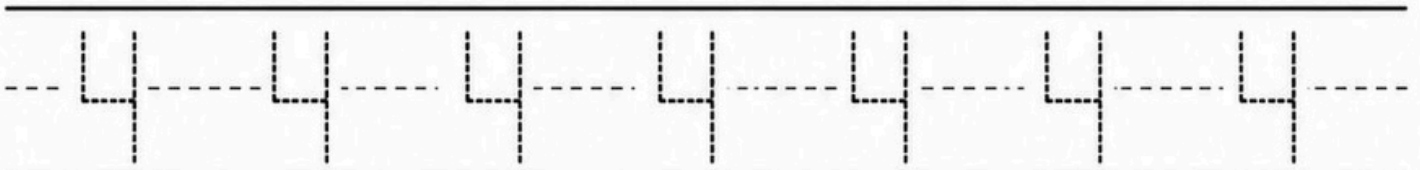
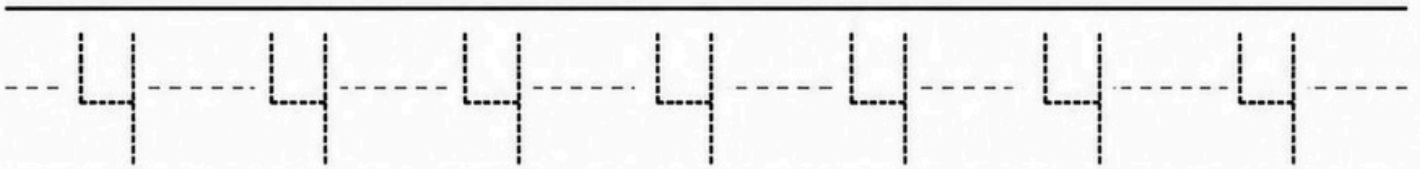

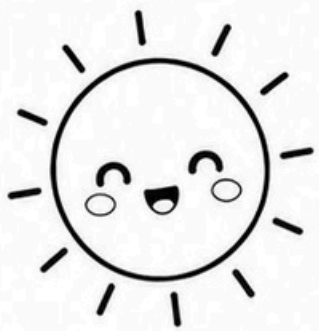

# TRAZO DEL NÚMERO 5

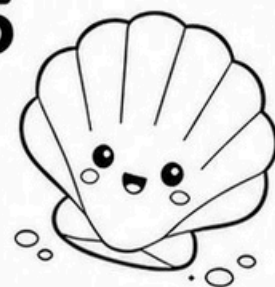

# CINCO

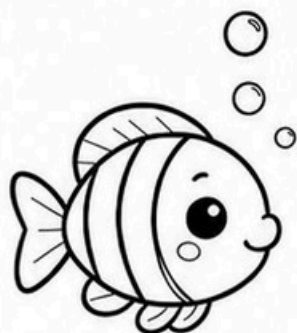
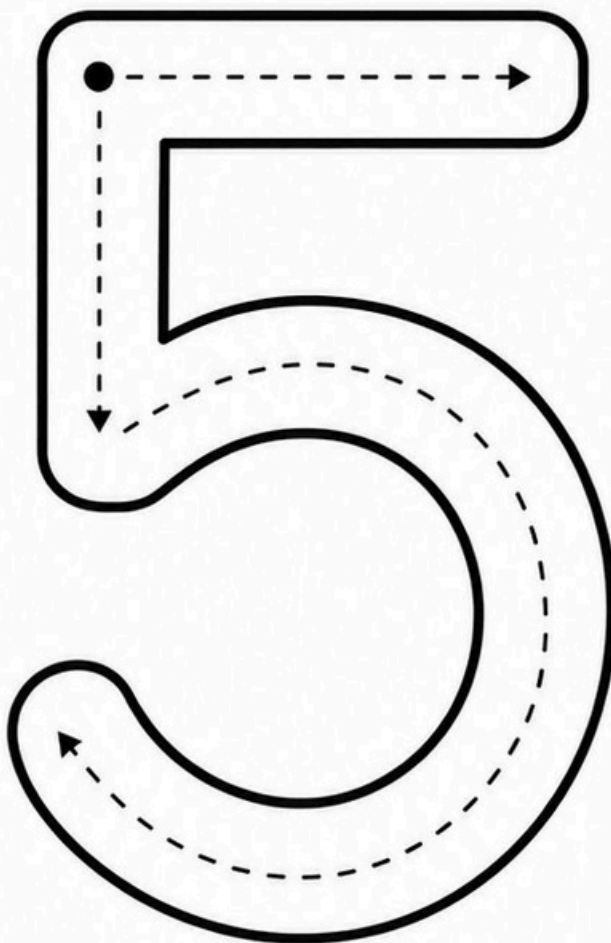

Repasa el número 5.

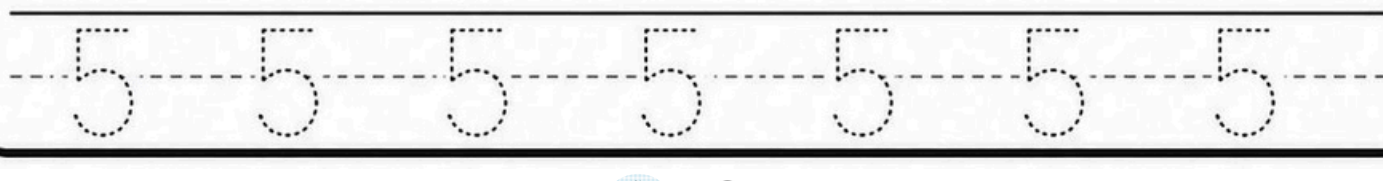
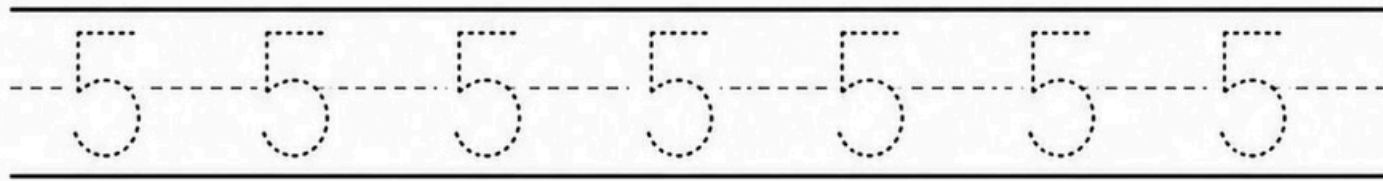
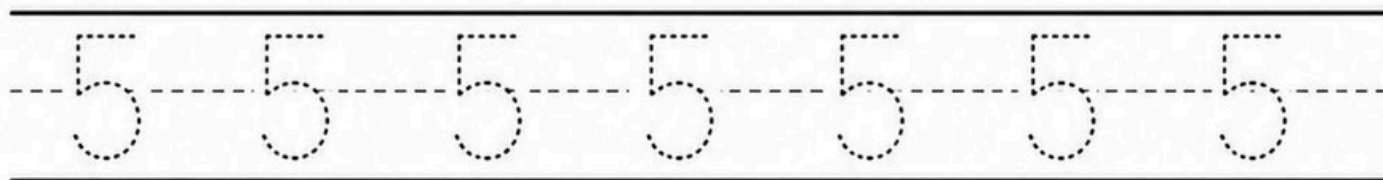



# TRAZO DEL NÚMERO 6

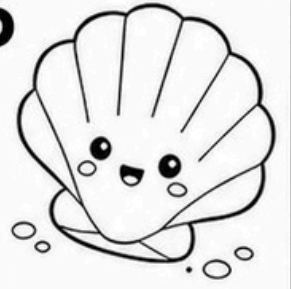

# SEIS

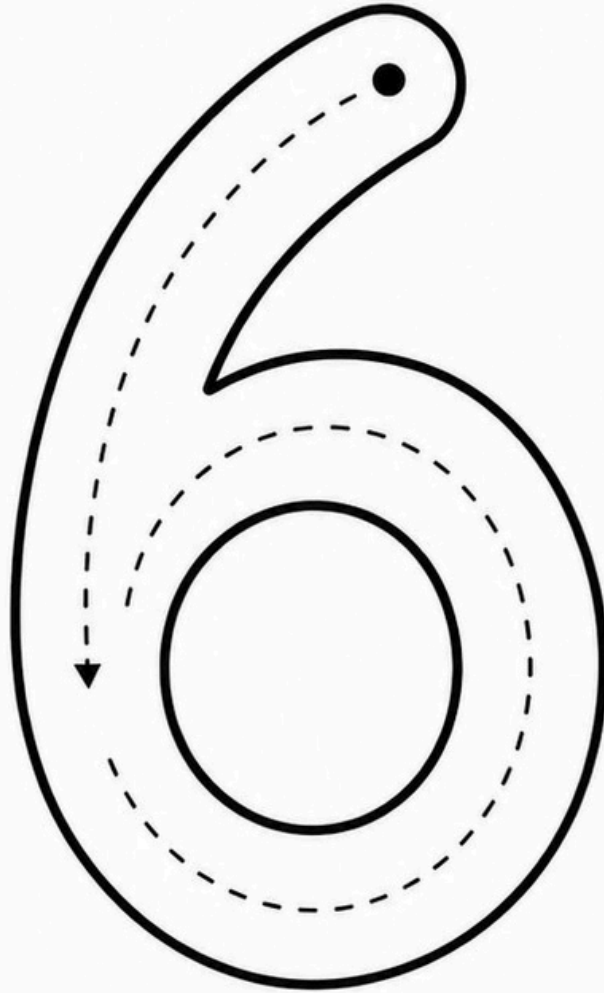

Repasa el número 6.

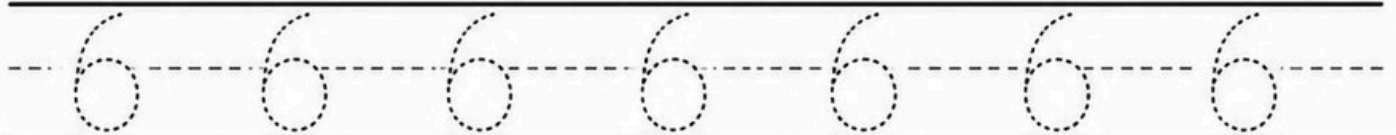
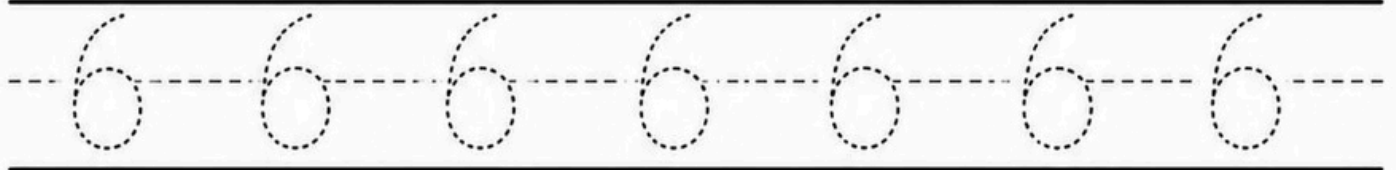
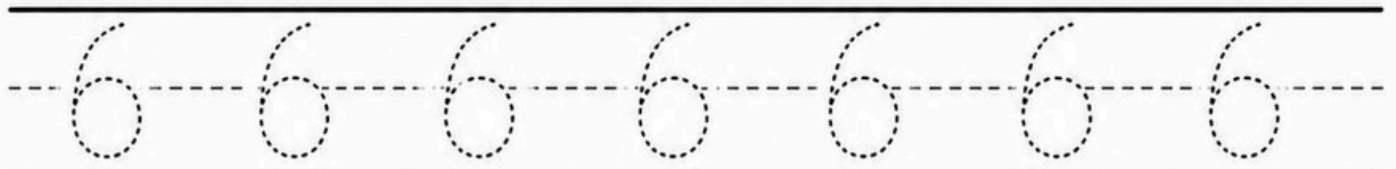



TRAZO DEL NÚMERO 7



SIETE

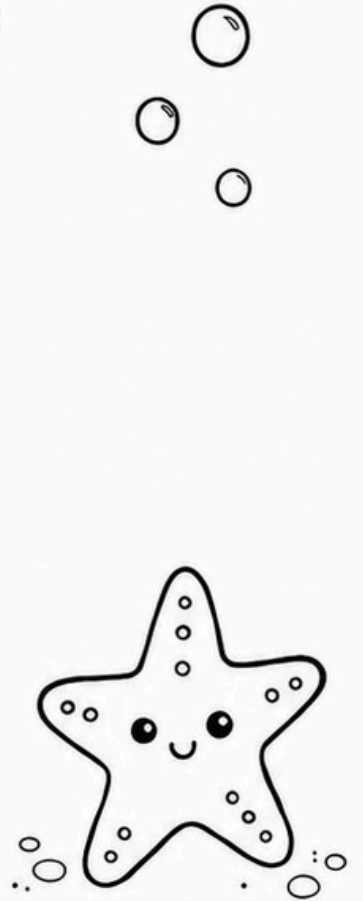
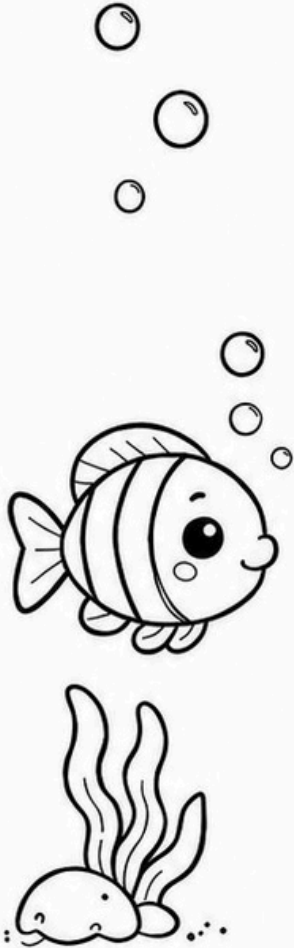
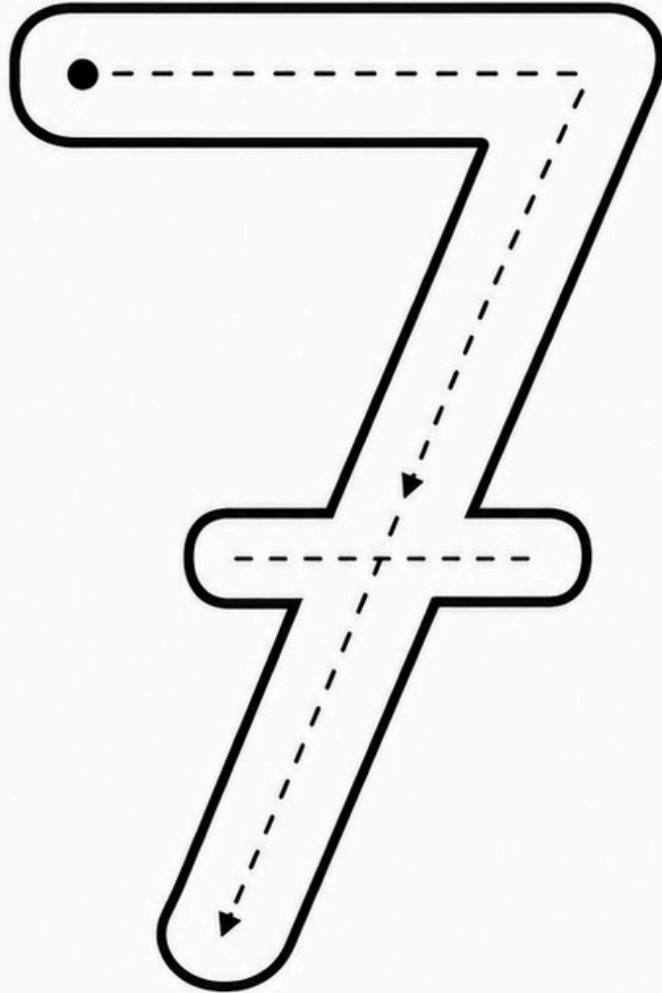

Repasa el número 7.

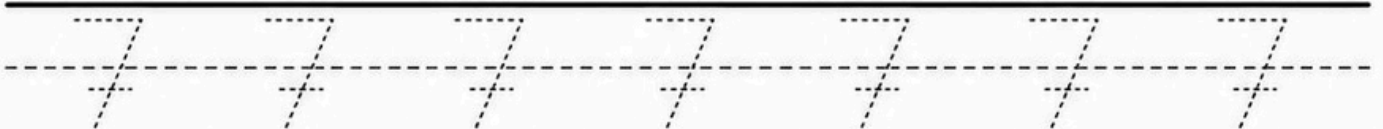
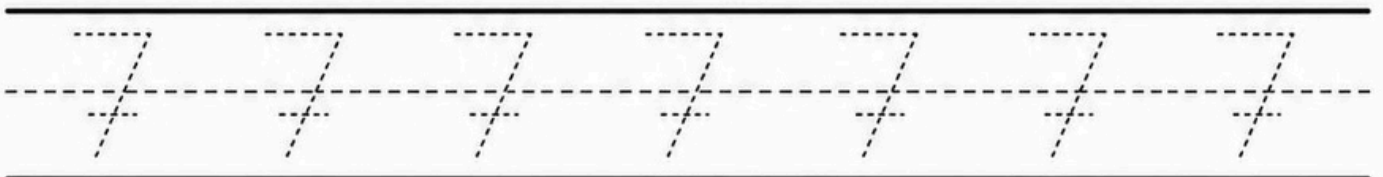
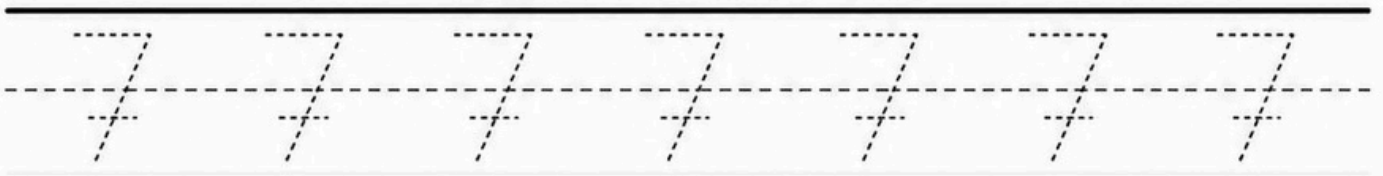



# TRAZO DEL NÚMERO 8



# OCHO

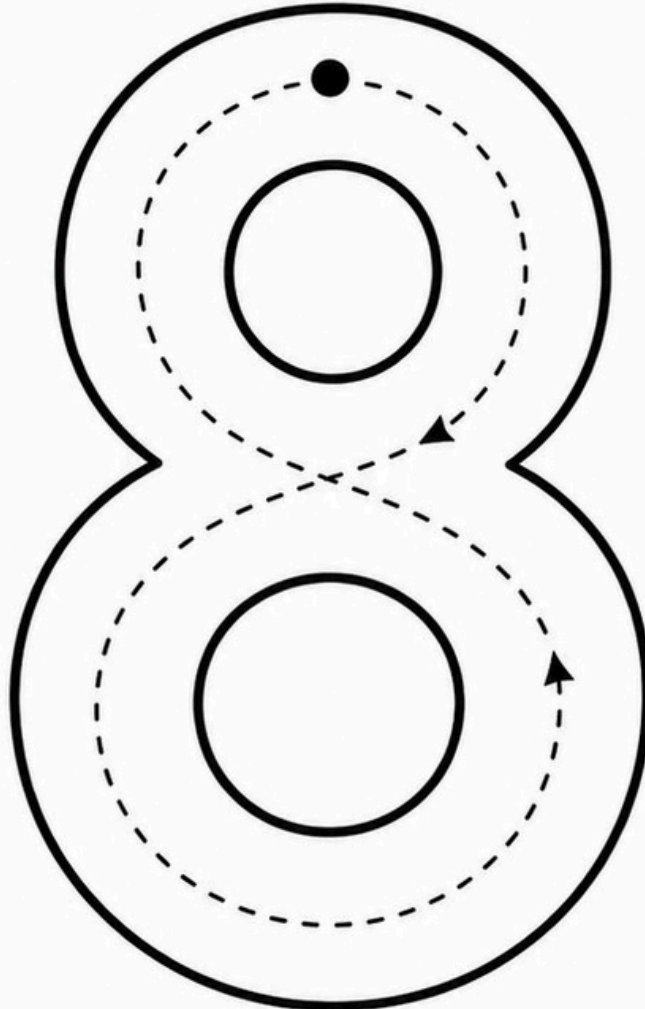

Repasa el número 8.

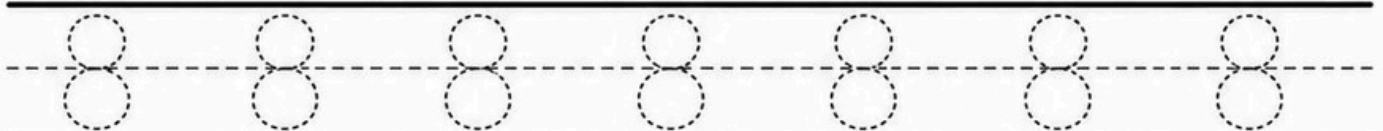
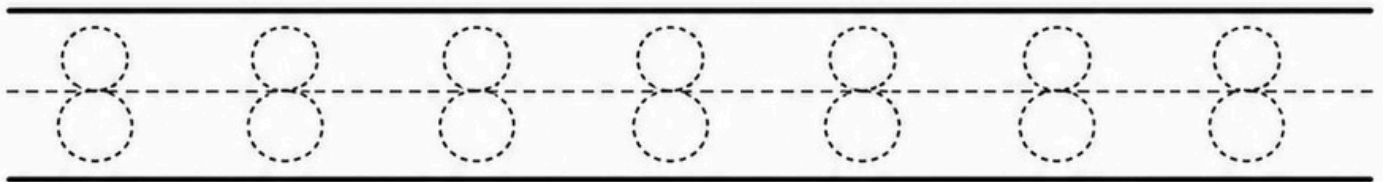
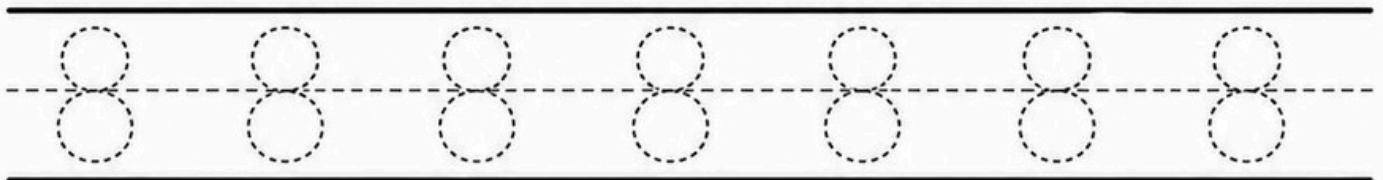

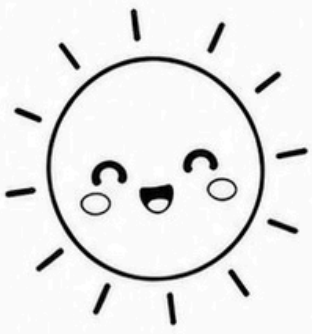

TRAZO DEL NÚMERO 9



NUEVE

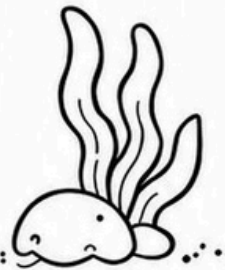
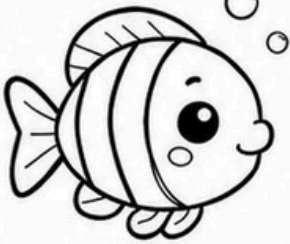
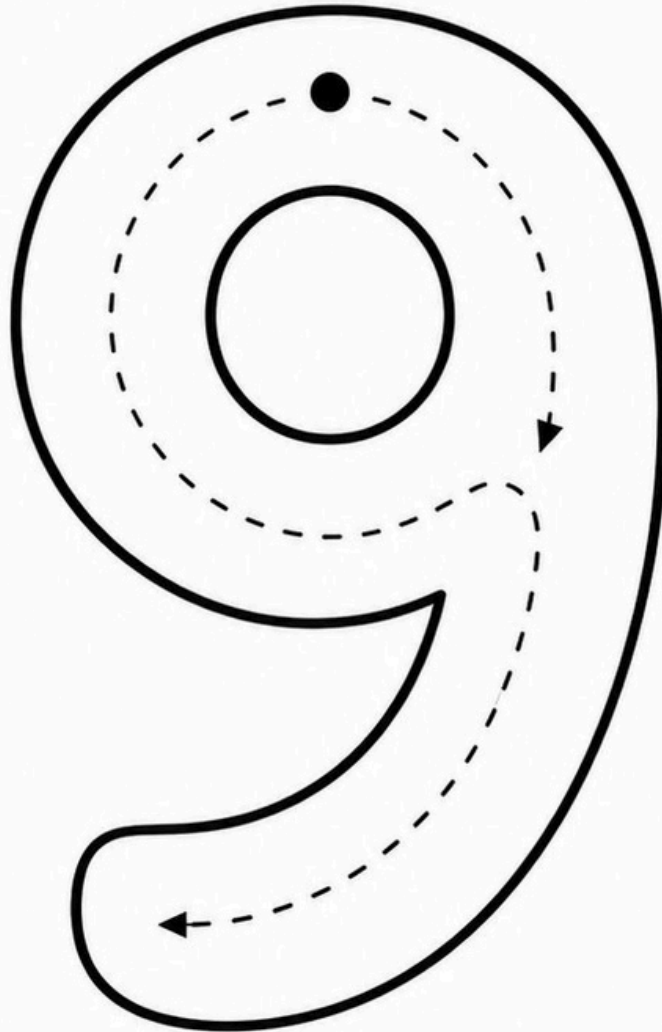

Repasa el número 9.

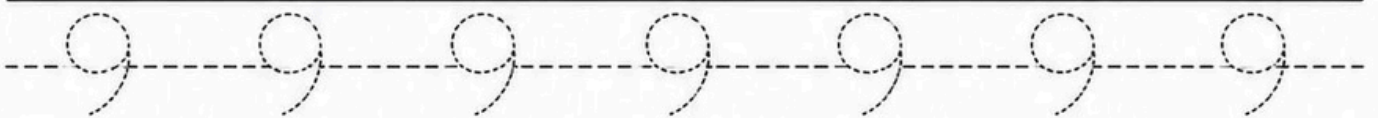
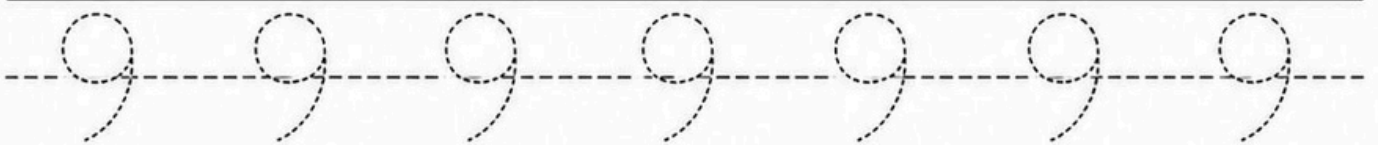
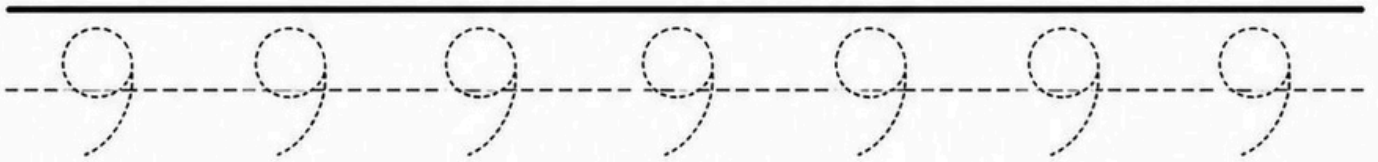



TRAZO DEL NÚMERO 10



DIEZ

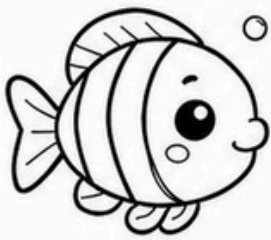
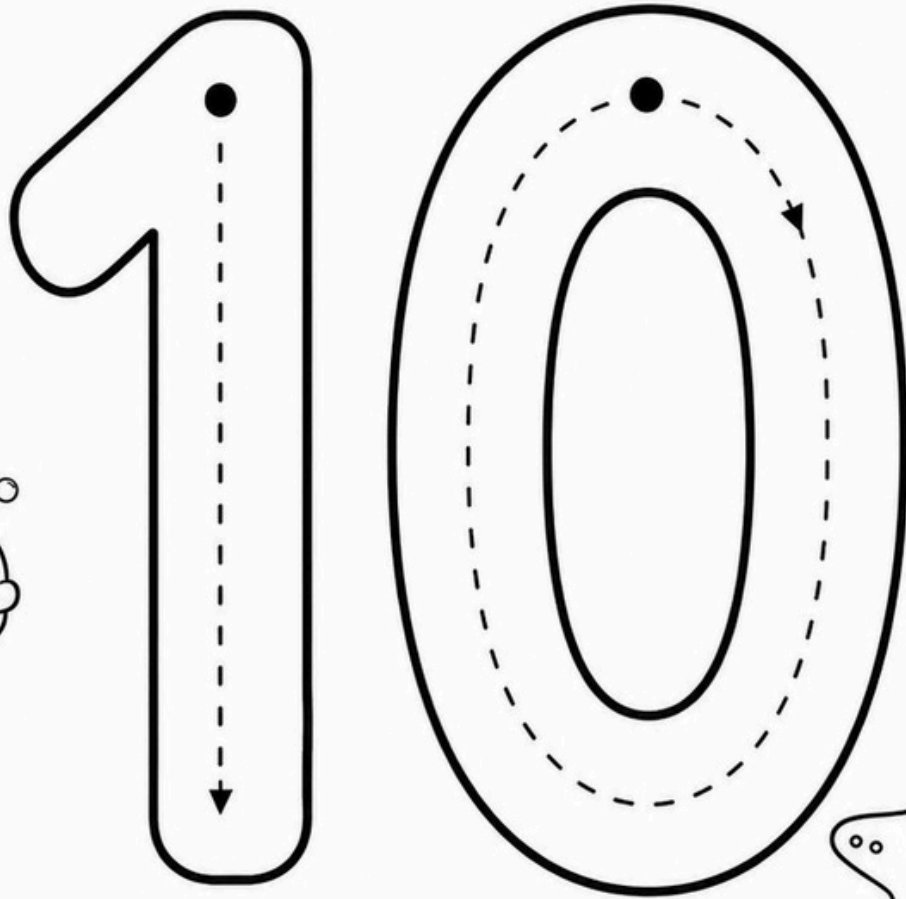

Repasa el número 10.

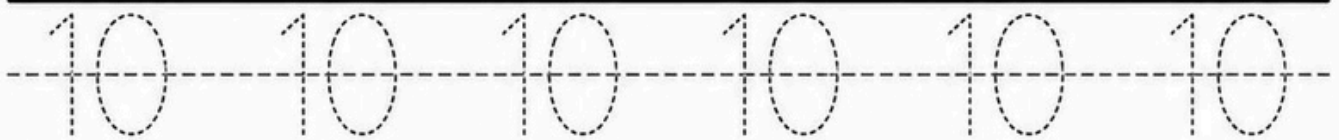
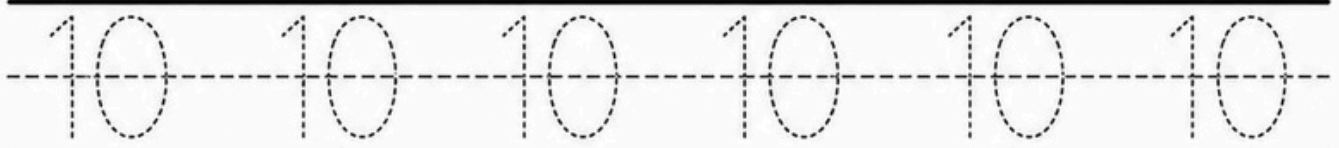
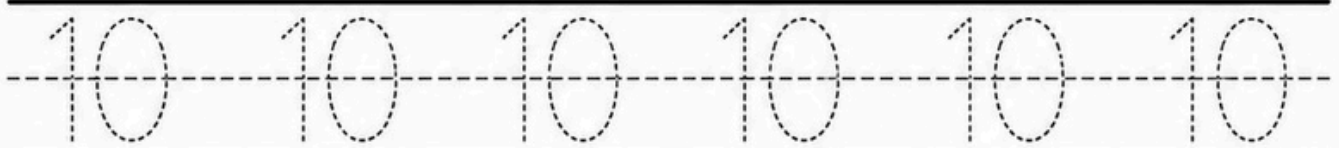



**TRAZA EL  
ÓVALO**

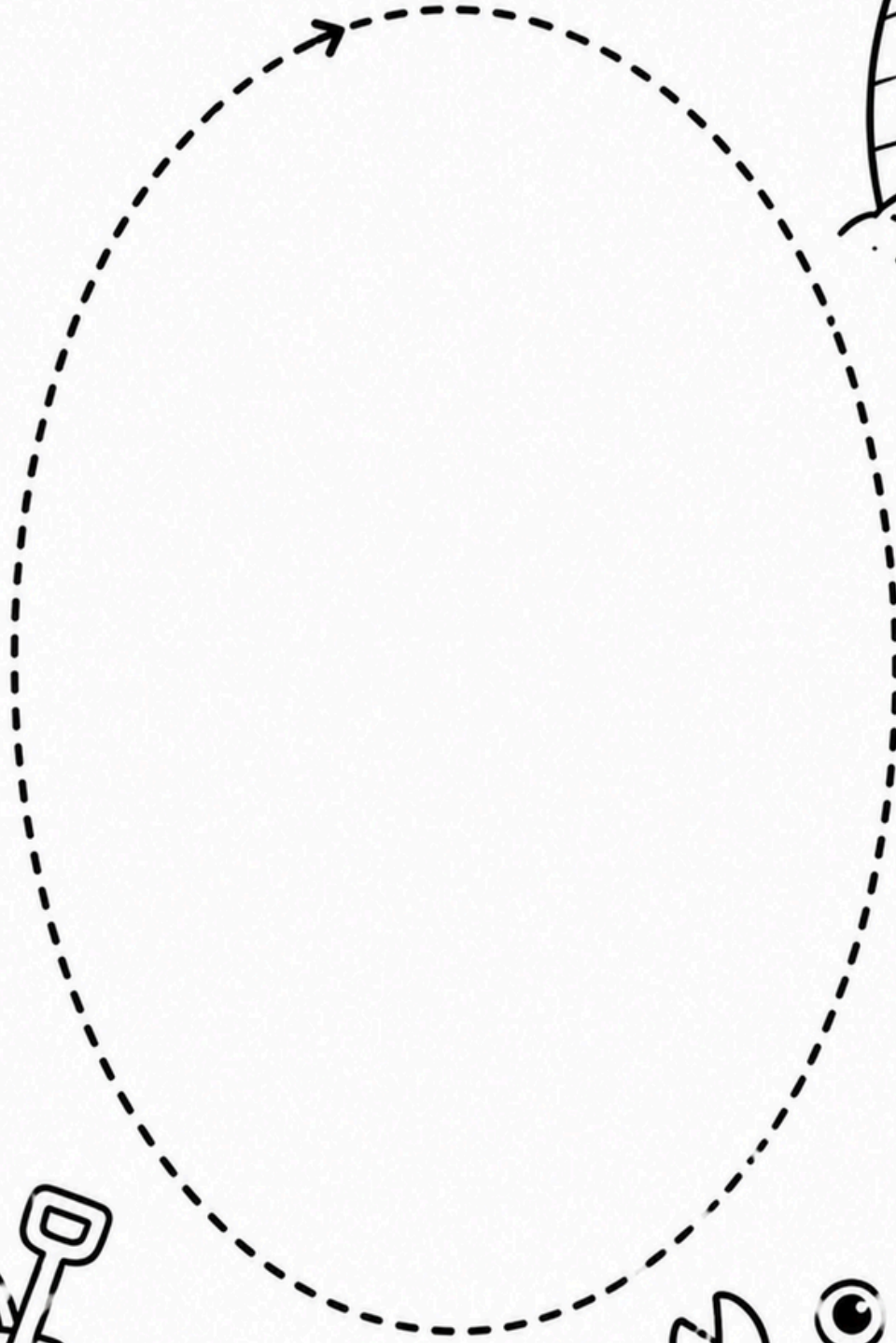
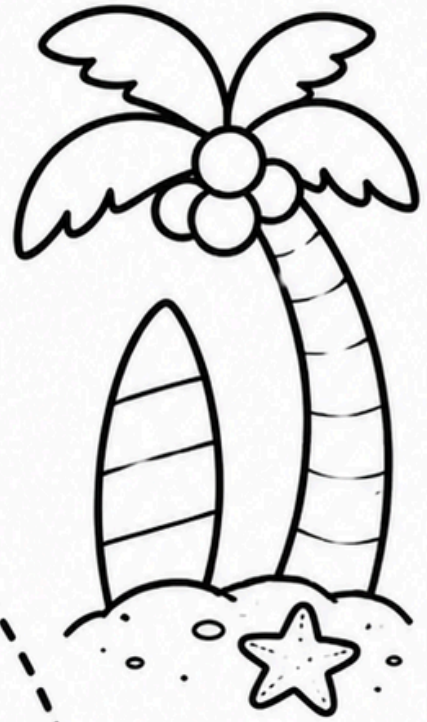



TRAZA EL  
RECTÁNGULO

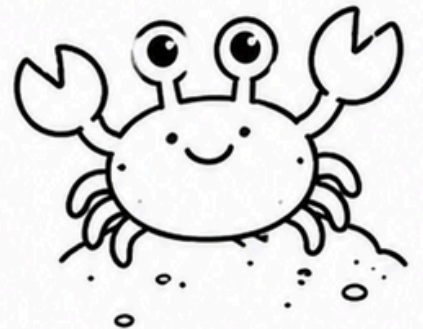
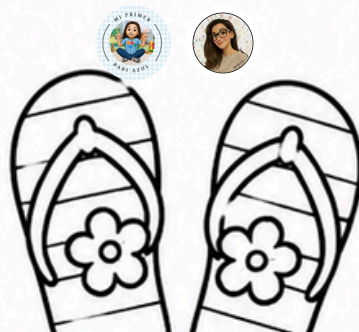
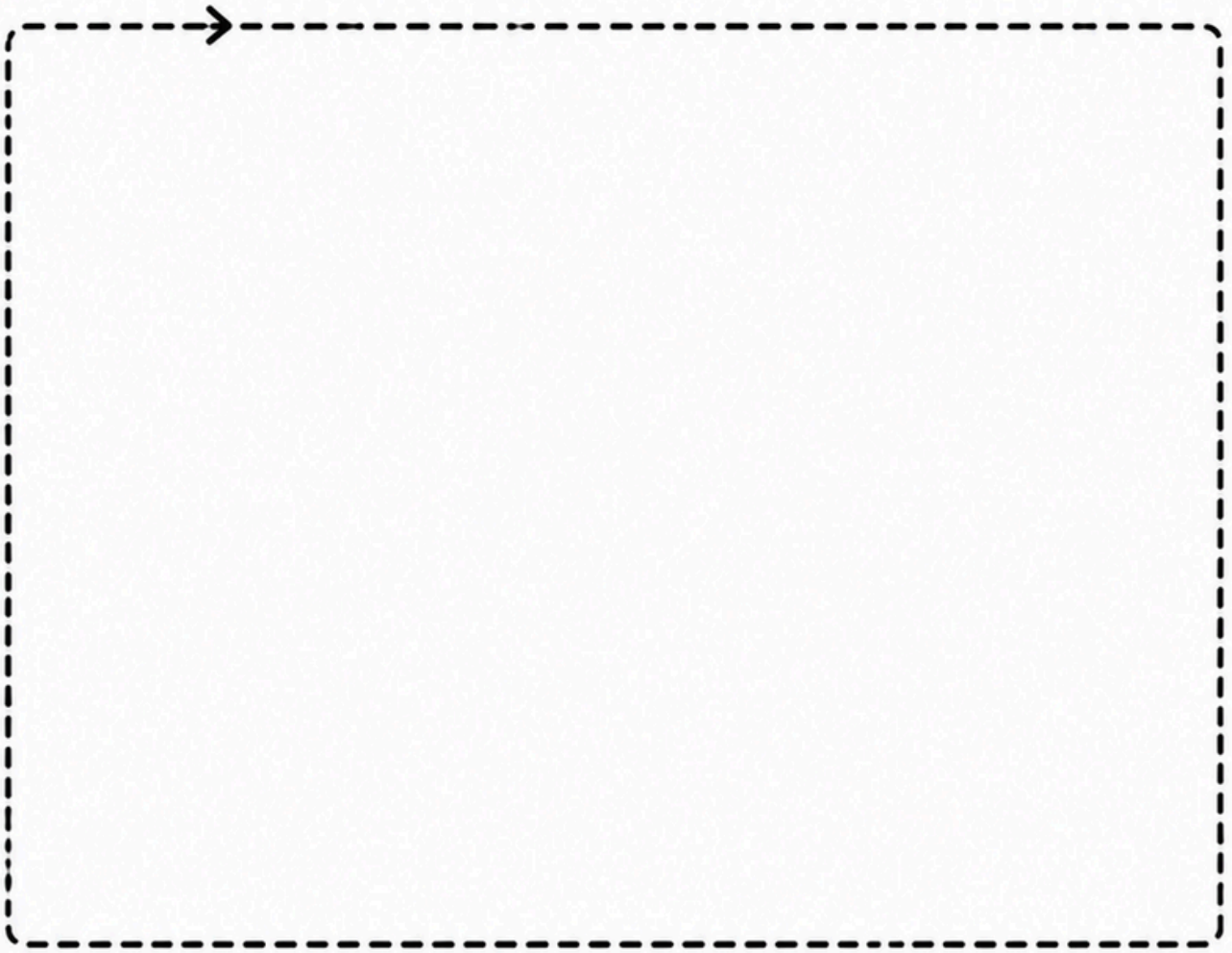
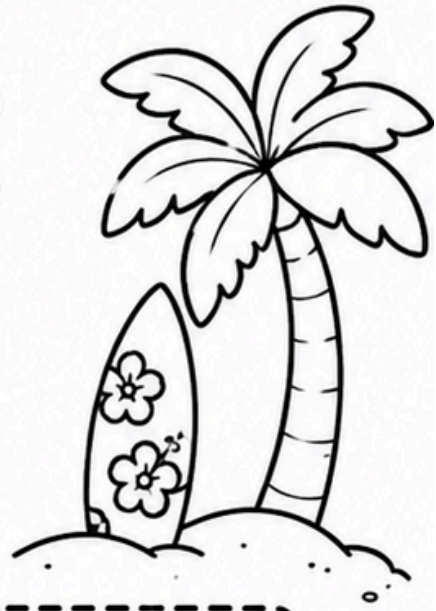



# MAR Y PECES

ASOCIO NÚMERO A CANTIDAD



Une cada número con la cantidad correcta de peces.



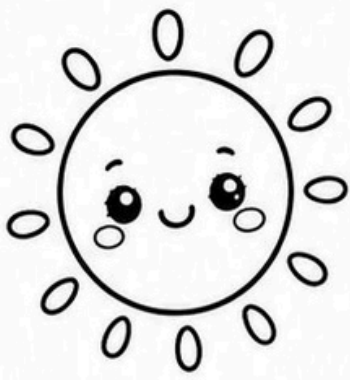

# HELADOS Y NÚMEROS

ASOCIO NÚMERO A CANTIDAD



Une cada número con la cantidad correcta de bolas de helado.

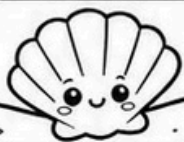

# Completa la serie

## Serie de 2 elementos

Observa el patrón y completa los últimos 2 espacios.

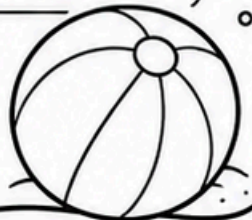
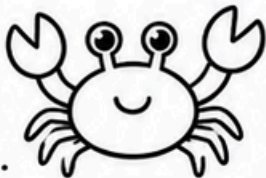
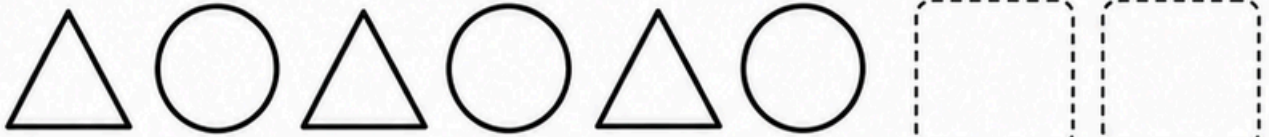
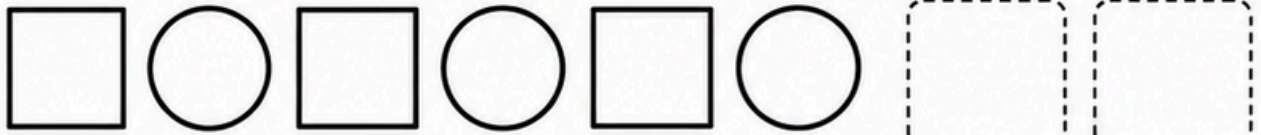
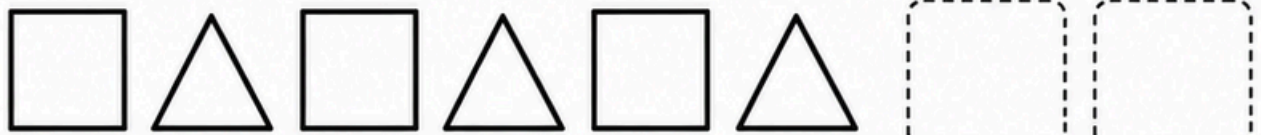

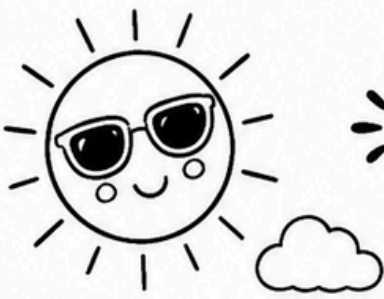

# COMPLETA LA SERIE

Sigue el patrón y completa los últimos 2 elementos.

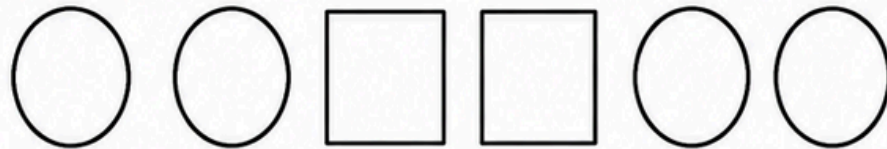

# ASOCIAMOS CANTIDAD Y OBJETO - ¡VERANO!

¡Hola! Cuenta los objetos, escribe el número y dibuja una línea para unirlos. ¡Luego colorea tu ficha de verano!

	3
--	---



	5
--	---

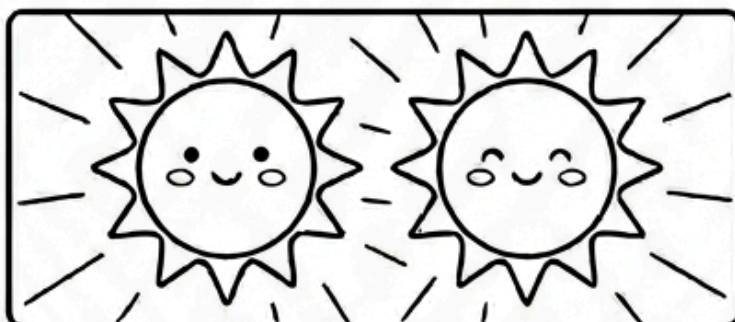

	1
--	---

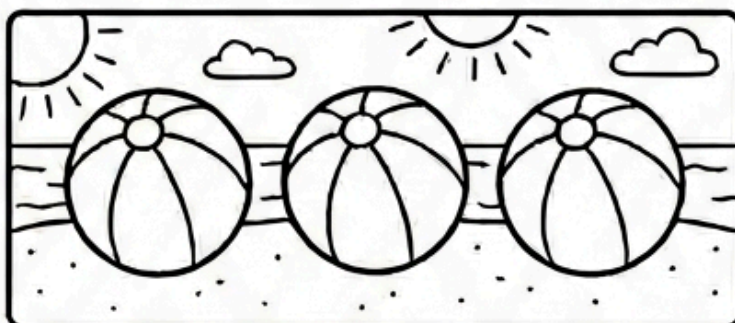

	2
--	---

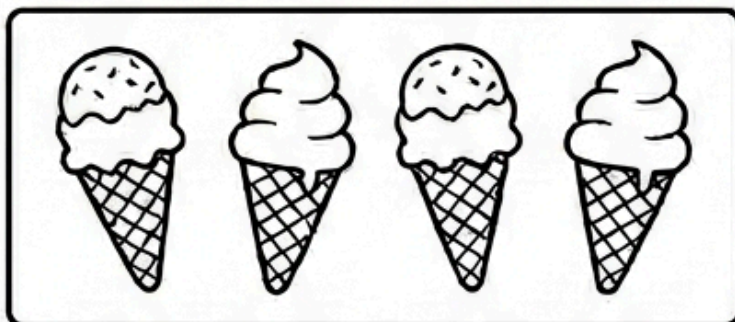

	4
--	---

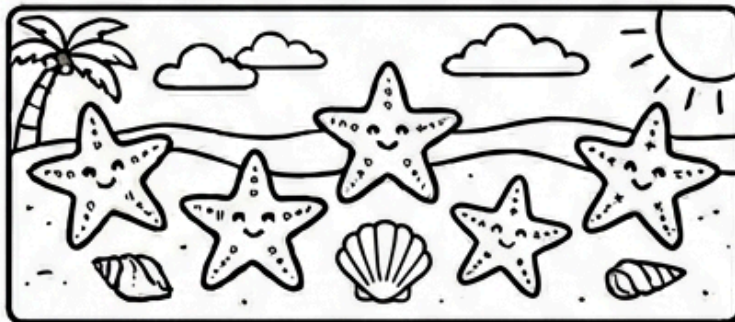

NOMBRE: \_\_\_\_\_ FECHA: \_\_\_\_/\_\_\_\_/\_\_\_\_



# ASOCIAMOS CANTIDAD Y OBJETO - ¡VERANO!

¡Pequeños! Cuenta los objetos de cada cuadro de la derecha y dibuja una línea para unirlo con el número correcto de la izquierda. Luego, colorea todo. ¡Divertíos mucho!

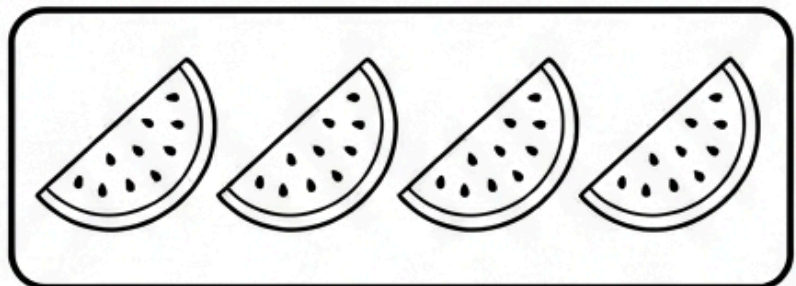
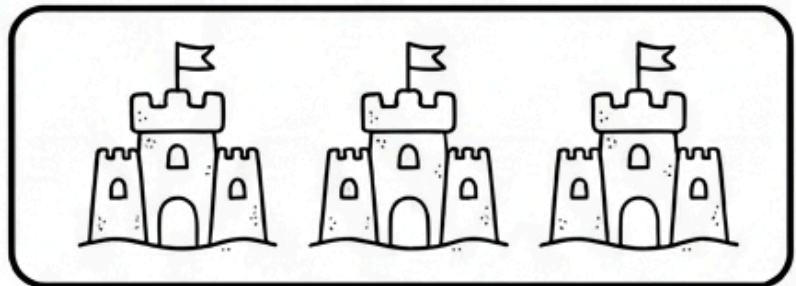
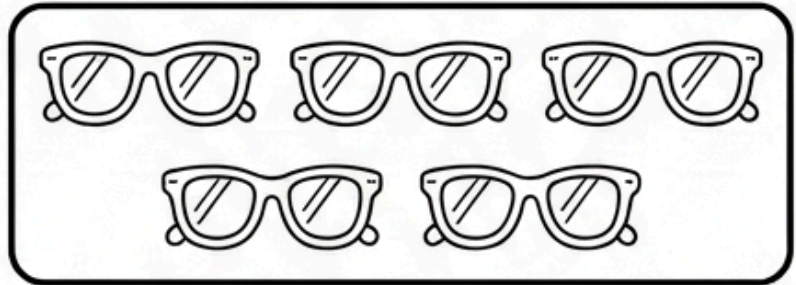
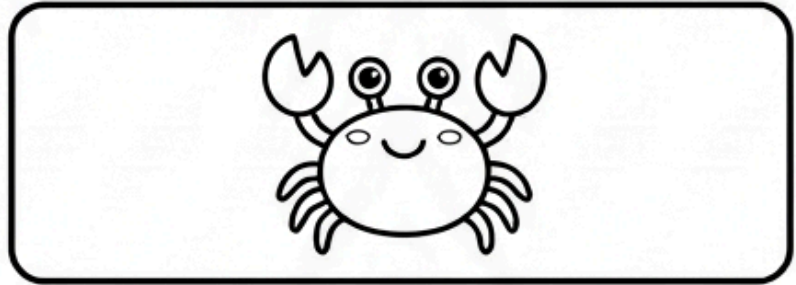
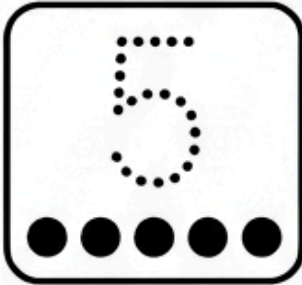

NOMBRE: \_\_\_\_\_

FECHA: \_\_\_/\_\_\_/\_\_\_

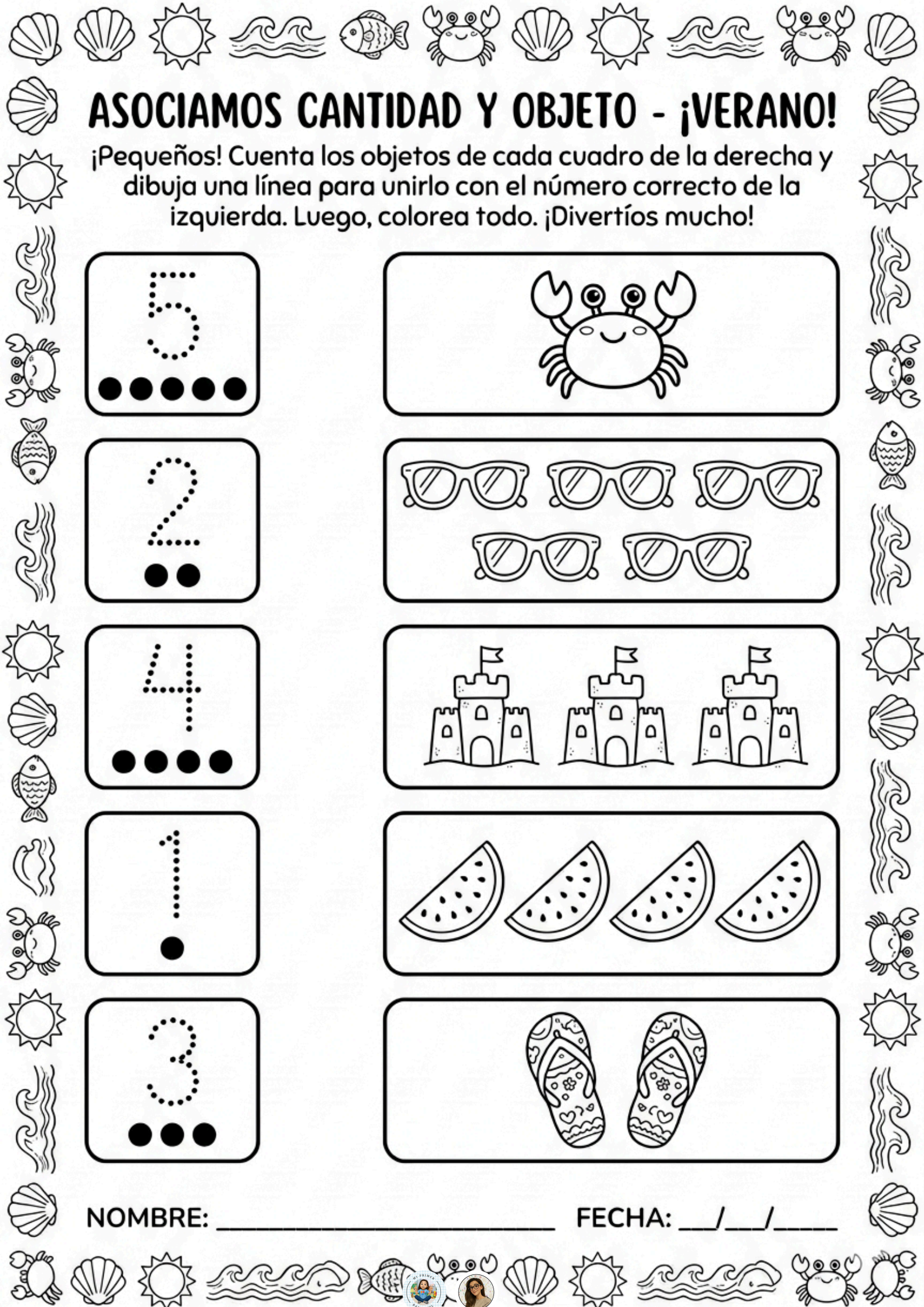

# FICHA DE MATEMÁTICAS: ¡CONTAMOS EL VERANO!

NOMBRE: \_\_\_\_\_ FECHA: \_\_\_\_\_

1. Cuenta y colorea el número correcto.

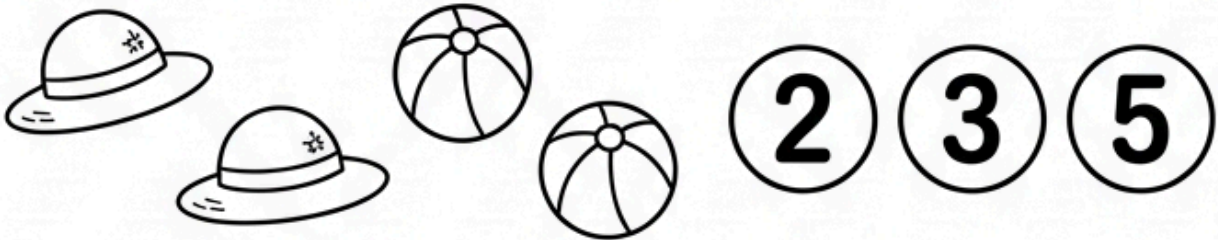

2. ¿Cuántos cubos de playa hay? ¡Colorea y rodea!



3. Dibuja las conchas que faltan hasta llegar a 5.

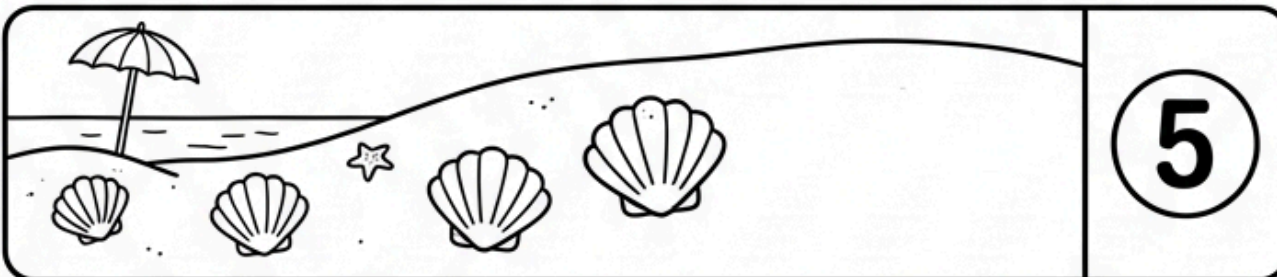

4. Cuenta los helados y une con el número.

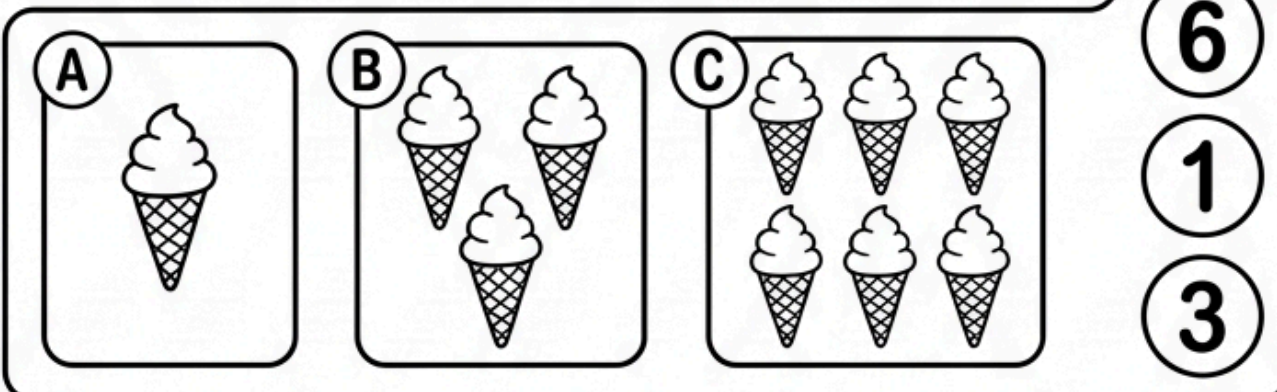

# ¡CONTEO VERANIEGO!

NOMBRE: \_\_\_\_\_ FECHA: \_\_\_\_\_

1. Cuenta las palmeras y rodea el número correcto.

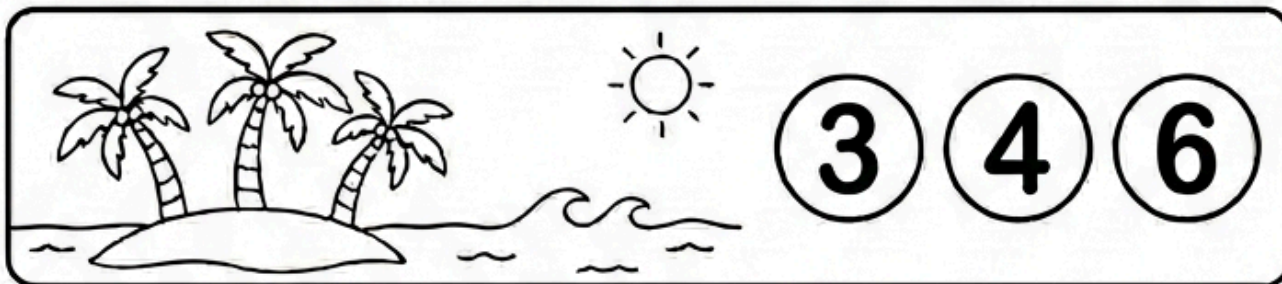

2. ¿Cuántas gafas de sol hay? ¡Colorea y rodea!

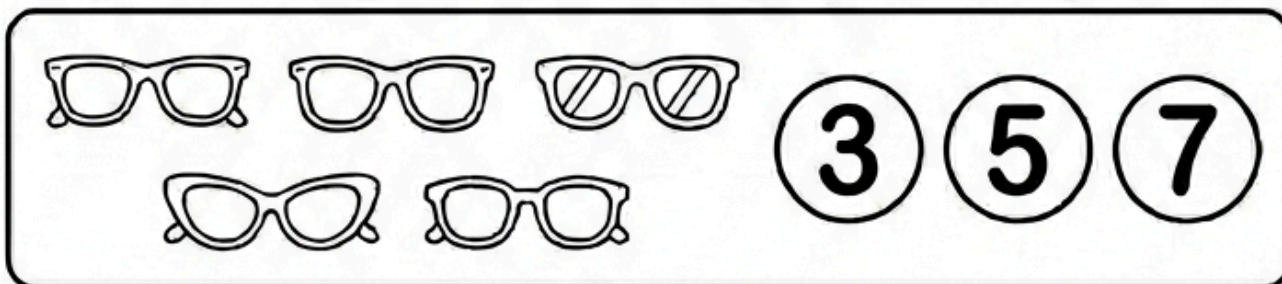

3. Cuenta todas las toallas de playa y rodea el número.

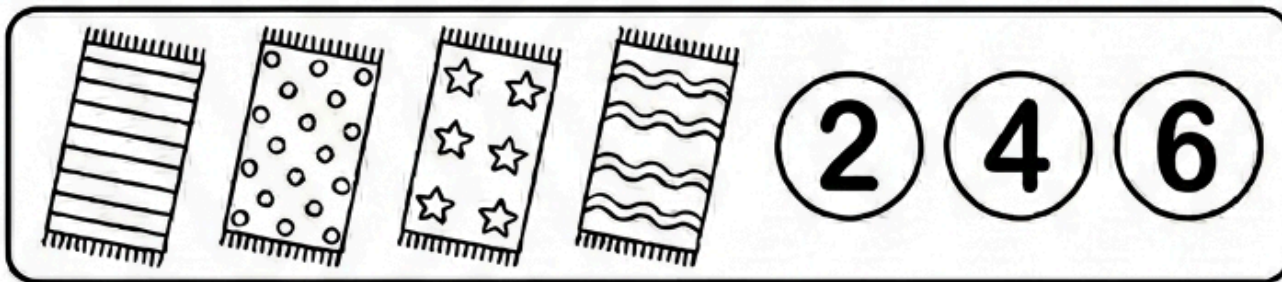

4. Cuenta las estrellas de mar y rodea el número.

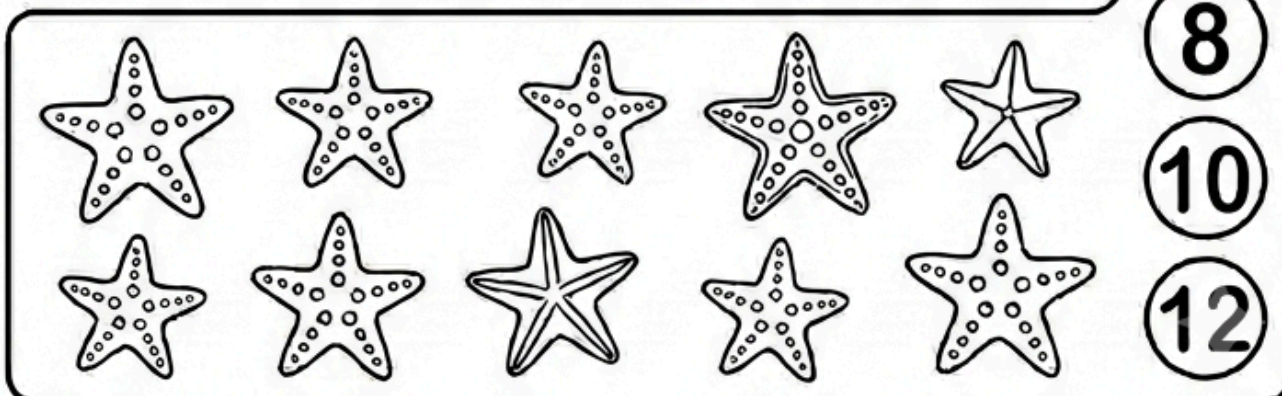

# ¡EXPLORADORES DEL VERANO!

NOMBRE: \_\_\_\_\_ FECHA: \_\_\_\_\_

5. Cuenta los helados y rodea el número correcto.



6. ¿Cuántos cubos de playa hay? ¡Colorea y rodea!



7. Cuenta todos los peces y rodea el número.

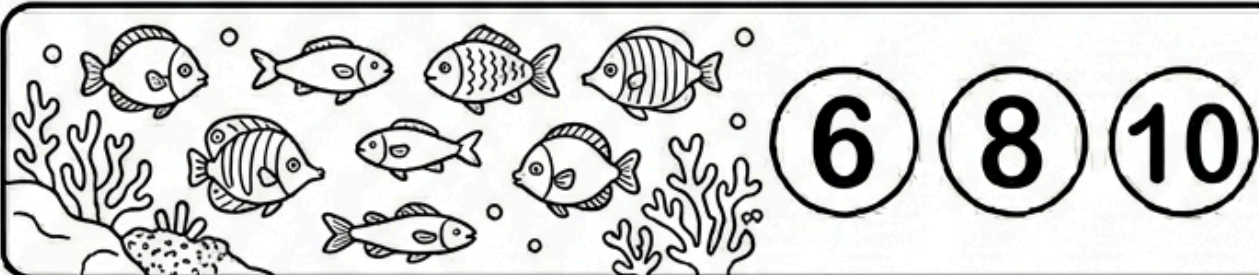

8. Cuenta las pelotas de playa y rodea el número.

